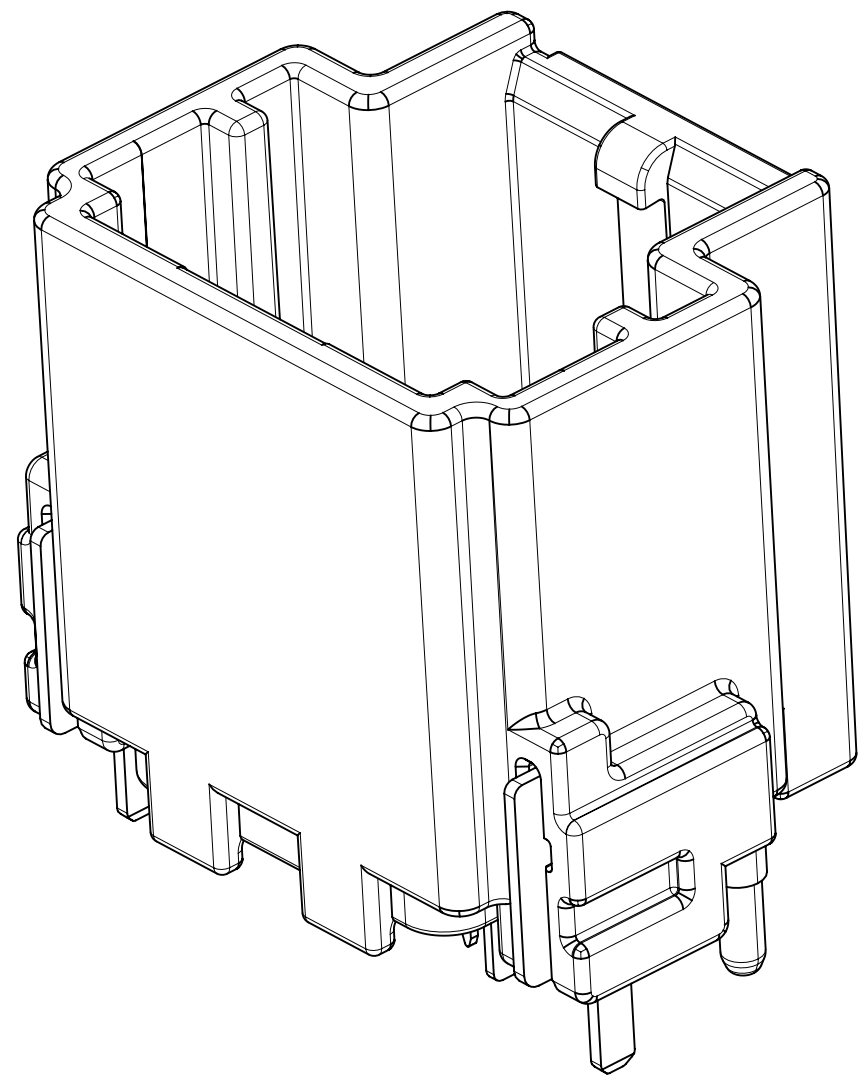

TABLE OF CONTENTS	
SHEET NO.	SHEET DESCRIPTION
1	NOTES & BOM
2	CONFIGURATIONS
3	CONNECTOR & PCB INTERFACE
4	RECOMMENDED PCB LAYOUT

DESCRIPTION	MATERIAL NUMBER	CIRCUIT SIZE	COLOR	STATUS
12CKT UNSEALED VERTICAL HEADER ASSEMBLY - KEY A	34862-1406	2X6	BLACK	SALEABLE
12CKT UNSEALED VERTICAL HEADER ASSEMBLY - KEY B	34862-1416	2X6	GREY	SALEABLE
12CKT UNSEALED VERTICAL HEADER ASSEMBLY - KEY C	34862-1426	2X6	BROWN	SALEABLE
12CKT UNSEALED VERTICAL HEADER ASSEMBLY W/ 2SHIELD TABS -KEY A	34862-1306	2X6	BLACK	SALEABLE
12CKT UNSEALED VERTICAL HEADER ASSEMBLY W/ 2SHIELD TABS -KEY B	34862-1316	2X6	GREY	SALEABLE
12CKT UNSEALED VERTICAL HEADER ASSEMBLY W/ 2SHIELD TABS -KEY C	34862-1326	2X6	BROWN	SALEABLE
12CKT UNSEALED VERTICAL HEADER ASSEMBLY W/ 2SHIELD TABS -KEY D	34862-1336	2X6	GREEN	SALEABLE

C2



4 SHIELD TAB VERSION
34862-14XX

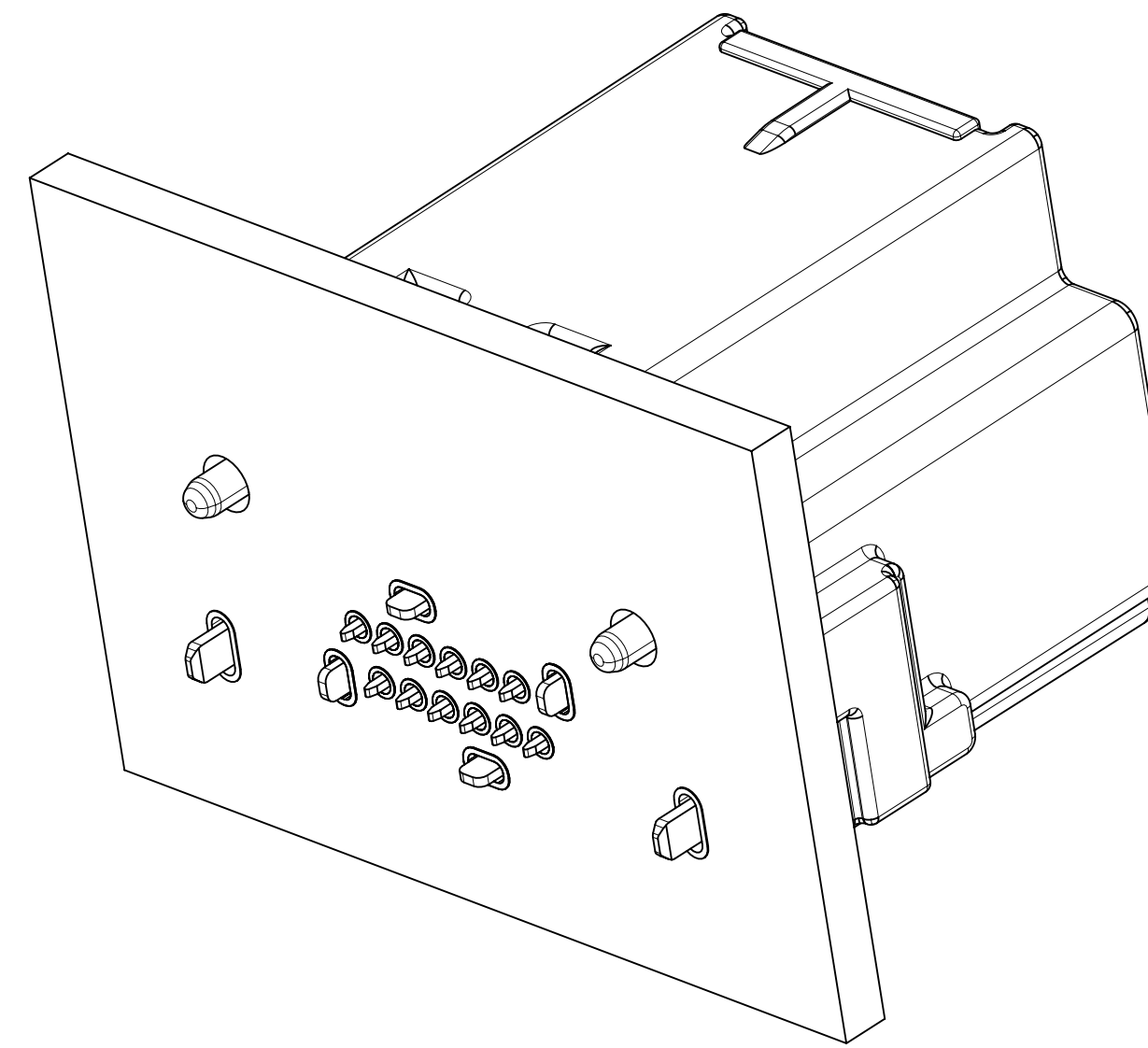

2 SHIELD TAB VERSION
34862-13XX

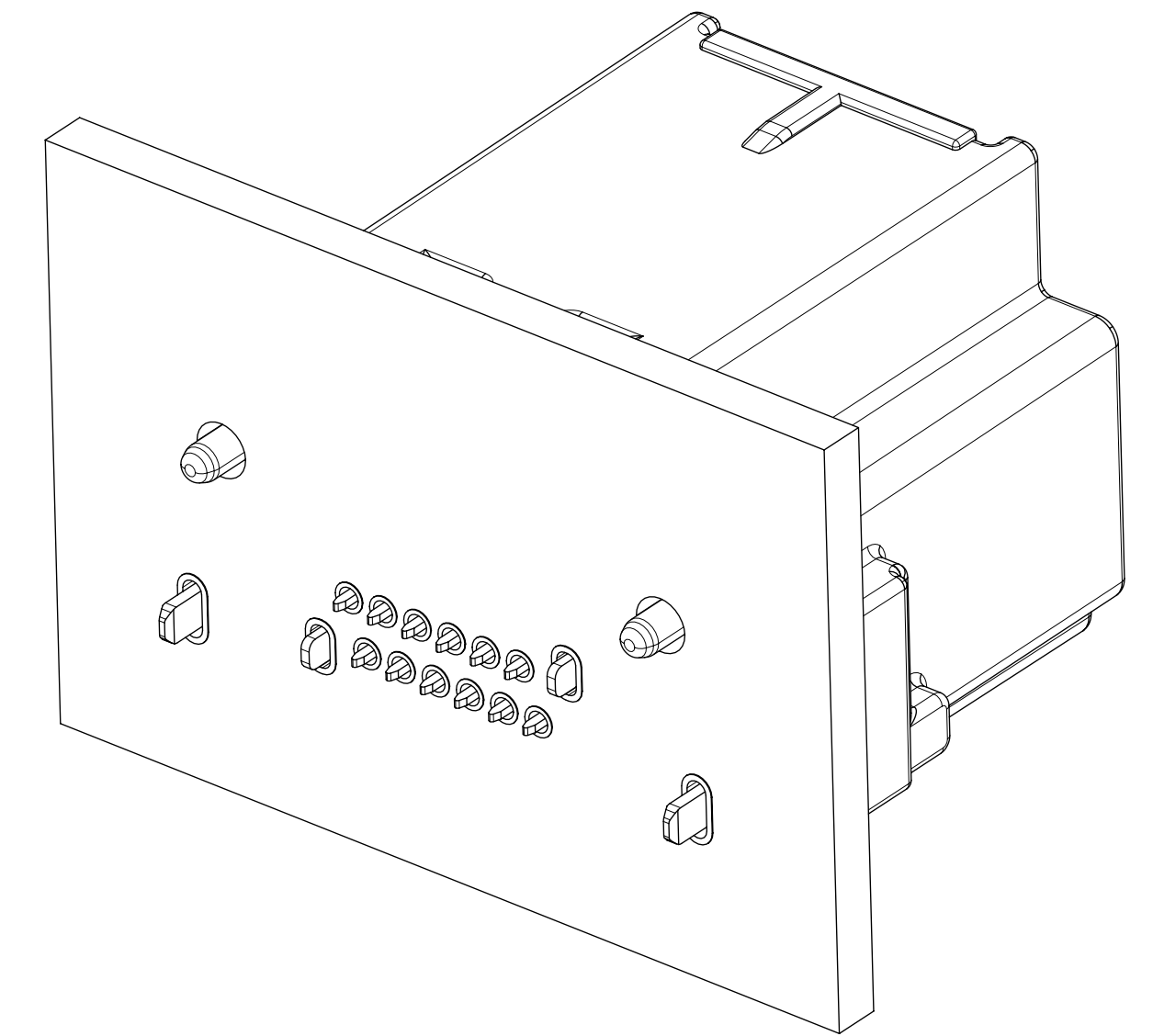

NOTES:

1. GENERAL:
 - a. APPLICATION SPECIFICATION SEE: AS-111149-002
 - b. PRODUCT SPECIFICATION SEE: PS-34861-001
 - c. PACKAGING SPECIFICATION PER MOLEX DRAWING: PK-34862-001
 - d. PARTS MUST BE IN COMPLIANCE TO MOLEX CHEMICAL SUBSTANCES FOR PRODUCTS AND PACKAGING SPECIFICATION: QEHS-699000-300
 - e. DATA MUST BE SUBMITTED UNDER THE MOLEX PART NUMBER TO IMDS (COMPANY ID#13255)
 - f. PCB TO BE FR4 .062" (1.57mm) THICK
 - g. MATING CONNECTOR MINIMUM CLEARANCE: REGION TO REMAIN CLEAR OF MODULE COMPONENTS, ADHESIVE, DEBRIS, ETC.
2. DESIGN - MATERIALS:
 - a. HEADER HOUSING - SPS GF30%
 - b. TERMINALS - COPPER ALLOY
OVERMOLDING - LCP GF30%
MATE-SIDE PLATING: SELECTIVE GOLD OVER NICKEL
PCB-SIDE PLATING: TIN OVER NICKEL
 - c. BISCUIT HOUSING - SPS GF30%
 - d. SHIELDS - COPPER ALLOY
PLATING (OVERALL): TIN OVER NICHEL
3. DESIGN - GEOMETRY:
 - a. GEOMETRIC DIMENSIONS AND TOLERANCES PER ASME Y14.5M-2009
 - b. EDGES AND UNDIMENSIONED DETAILS PER ISO13715
 - c. CORNERS SHOWN AS SHARP TO BE R0.2 MAX.
4. LASER MARKING TO BE MARKED WITH:
 - HUMAN READABLE CODE (HRC)
 - PERMANENTLY APPLIED ON THE PART WITH 1.5MM LETTER SIZE
 - 5DIGIT JULIAN MANUFACTURING DATE STAMP YYDDD

C2	ADDED PART NUMBER 34862-1336.	PRAVEEN	25NOV2021
C1	UPDATED PCB LAYOUT - PIN HOLE DIA	SUDAYGUNAGI	01JULY2020
REV	DESCRIPTION	ENGINEER	DATE

THIS DRAWING CONTAINS INFORMATION THAT IS PROPRIETARY TO MOLEX ELECTRONIC TECHNOLOGIES, LLC AND SHOULD NOT BE USED WITHOUT WRITTEN PERMISSION									
DIMENSION UNITS	SCALE	CURRENT REV DESC:							
mm	5:1								
GENERAL TOLERANCES (UNLESS SPECIFIED)		EC NO: 686690			12 CKT HSAUTOLINK II VERTICAL HEADER VERTICAL UNSEALED HEADER ASSEMBLY PRODUCT CUSTOMER DRAWING				
ANGULAR TOL	± °	DRWN: PRAVEC2 2021/11/24							
4 PLACES	±	CHK'D: SMAMIDINAGAV 2021/12/09			DOCUMENT NUMBER: 348621406 DOC TYPE: PSD DOC PART: 000 REVISION: C2				
3 PLACES	±	APPR: SMAMIDINAGAV 2021/12/09							
2 PLACES	± 0.13	INITIAL REVISION:			MATERIAL NUMBER: 34862 CUSTOMER: GENERAL MARKET SHEET NUMBER: 1 OF 4				
1 PLACE	± 0.25	DRWN: XLHE14 2018/06/25							
0 PLACES	±	APPR: DNAYLIS 2018/06/27			DRAFT WHERE APPLICABLE MUST REMAIN WITHIN DIMENSIONS				
THIRD ANGLE PROJECTION		DRAWING		SERIES					
		D-SIZE		34862					

SHEET DESCRIPTION
CONFIGURATIONS

MATE INTERFACE
KEY OPTIONS

PCB INTERFACE
KEY OPTIONS

P/N: 34862-1406
KEY OPTION A
COLOR: BLACK

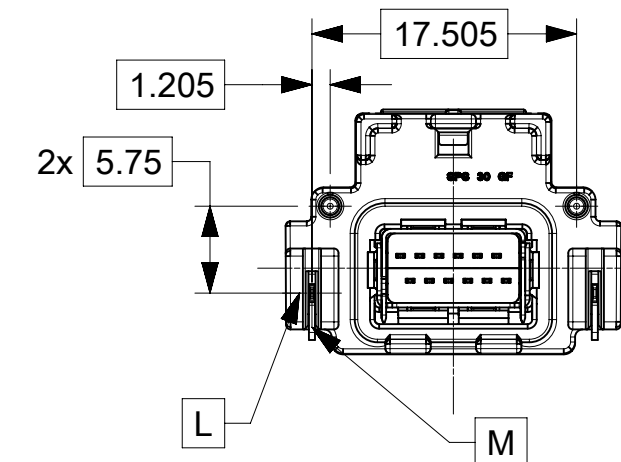
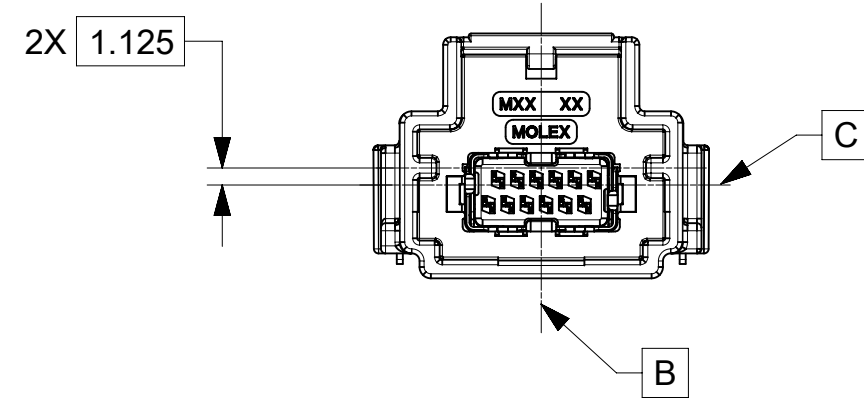
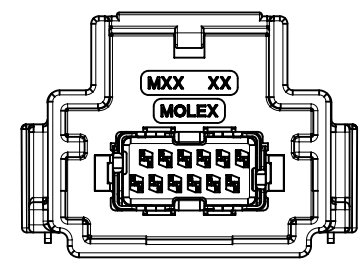

P/N: 34862-1416
KEY OPTION B
COLOR: GREY

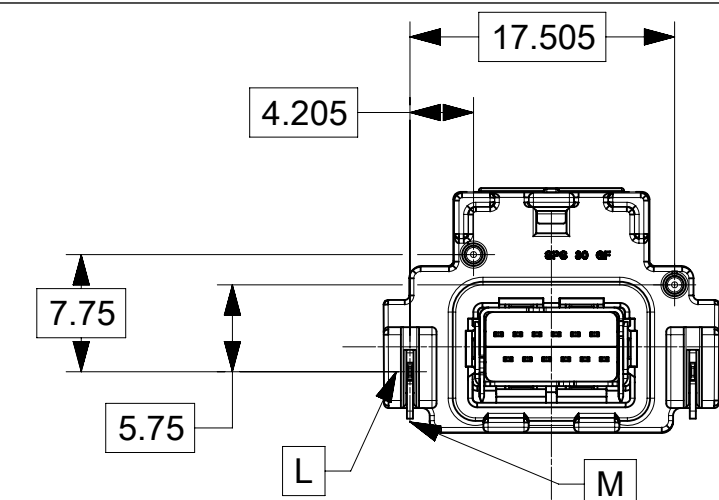
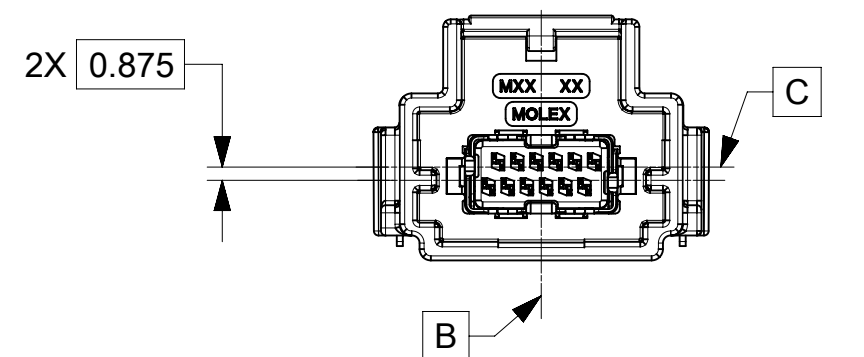
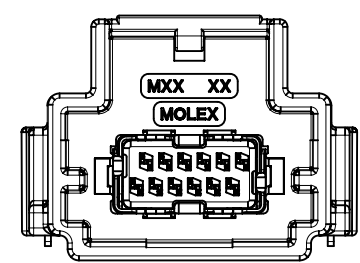

P/N: 34862-1426
KEY OPTION C
COLOR: BROWN

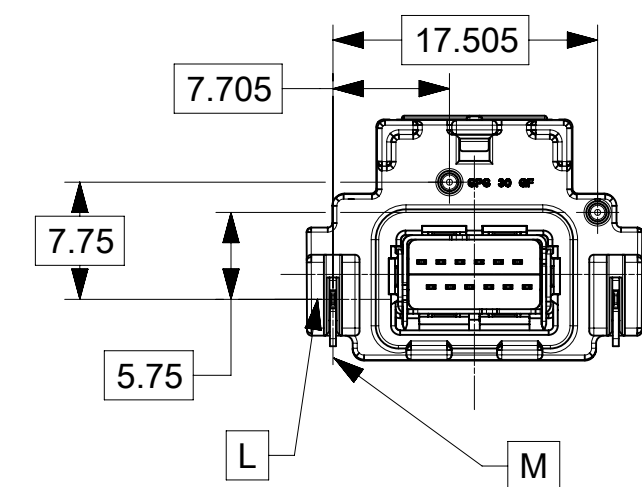
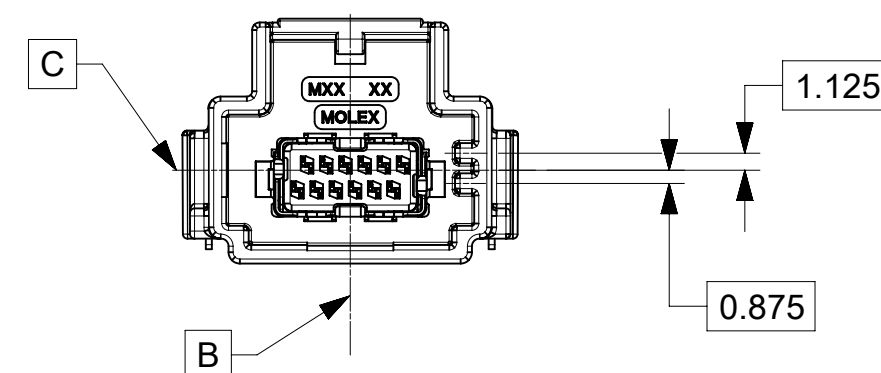
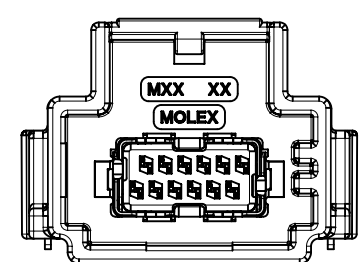

P/N: 34862-1336
KEY OPTION D
COLOR: GREEN

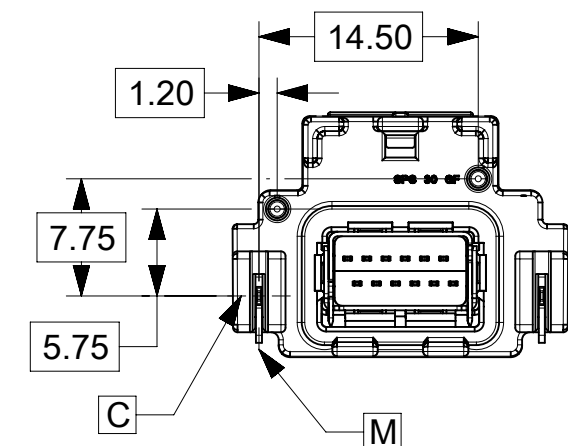
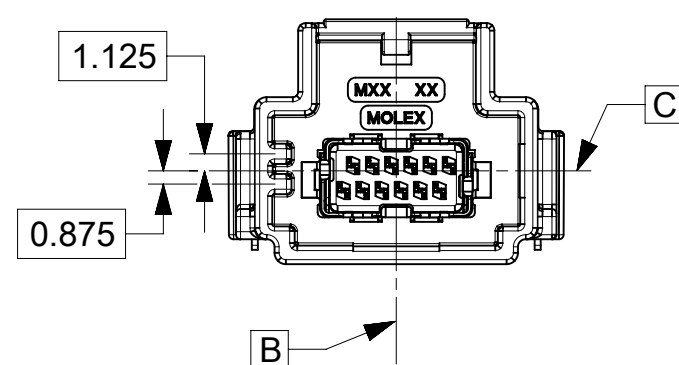
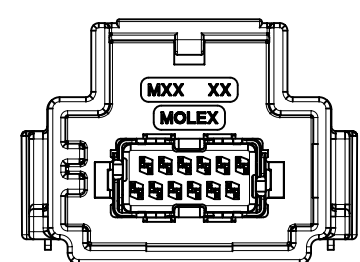

THIS DRAWING CONTAINS INFORMATION THAT IS PROPRIETARY TO MOLEX ELECTRONIC TECHNOLOGIES, LLC AND SHOULD NOT BE USED WITHOUT WRITTEN PERMISSION											
DIMENSION UNITS		SCALE		CURRENT REV DESC:							
mm		2:1									
GENERAL TOLERANCES (UNLESS SPECIFIED)				EC NO: 686690						12 CKT HSAUTOLINK II VERTICAL HEADER VERTICAL UNSEALED HEADER ASSEMBLY	
ANGULAR TOL ± °				DRWN: PRAVEC2 2021/11/24							
4 PLACES ±				CHK'D: SMAMIDINAGAV 2021/12/09						PRODUCT CUSTOMER DRAWING	
3 PLACES ±				APPR: SMAMIDINAGAV 2021/12/09							
2 PLACES ± 0.13				INITIAL REVISION:						DOCUMENT NUMBER: 348621406 DOC TYPE: PSD DOC PART: 000 REVISION: C2	
1 PLACE ± 0.25				DRWN: XLHE14 2018/06/25							
0 PLACES ±				APPR: DNAYLIS 2018/06/27						MATERIAL NUMBER: SEE SHEET 1 CUSTOMER: GENERAL MARKET SHEET NUMBER: 2 OF 4	
DRAFT WHERE APPLICABLE MUST REMAIN WITHIN DIMENSIONS		THIRD ANGLE PROJECTION		DRAWING: D-SIZE		SERIES: 34862					

SHEET DESCRIPTION
CONNECTOR INTERFACE

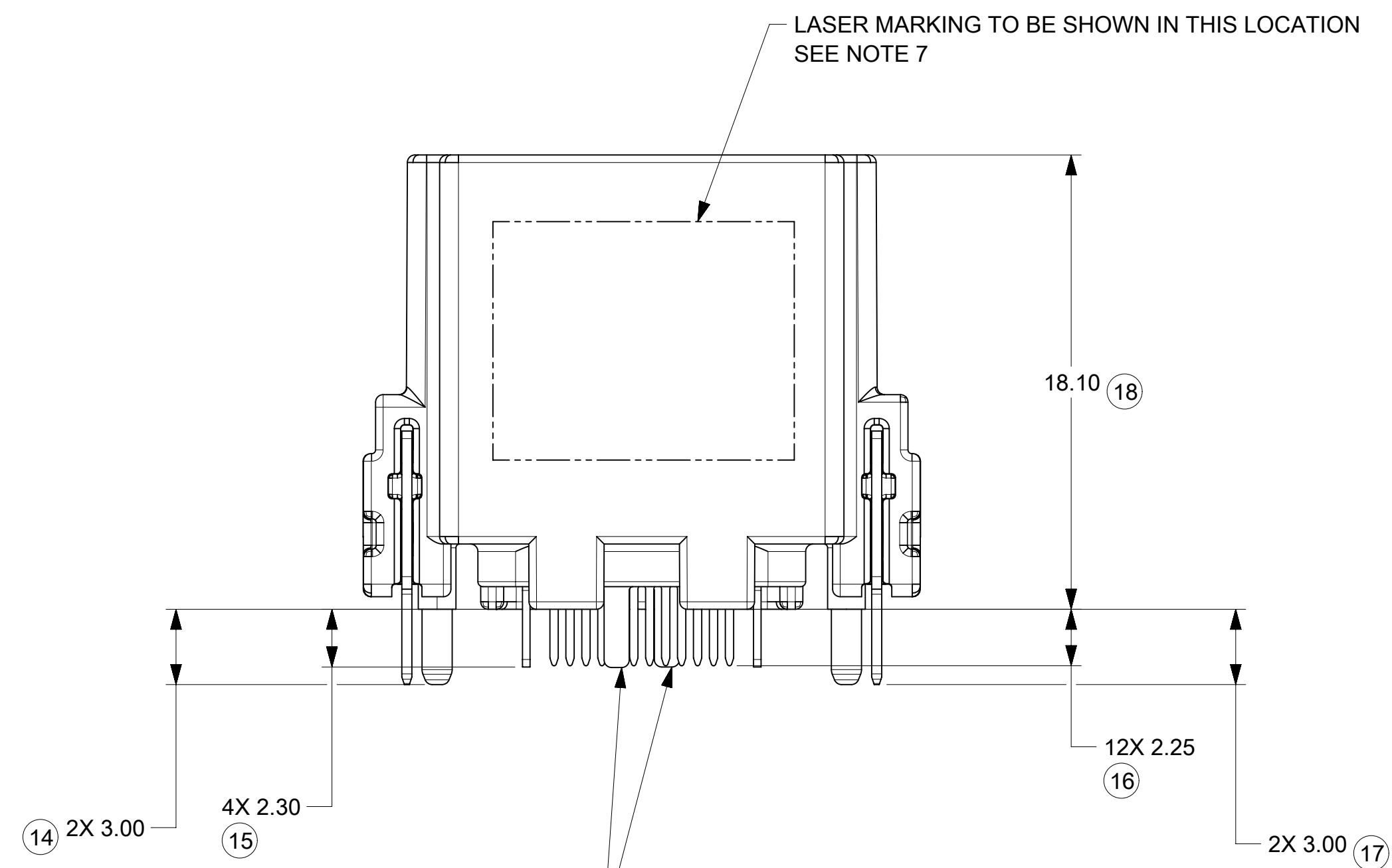
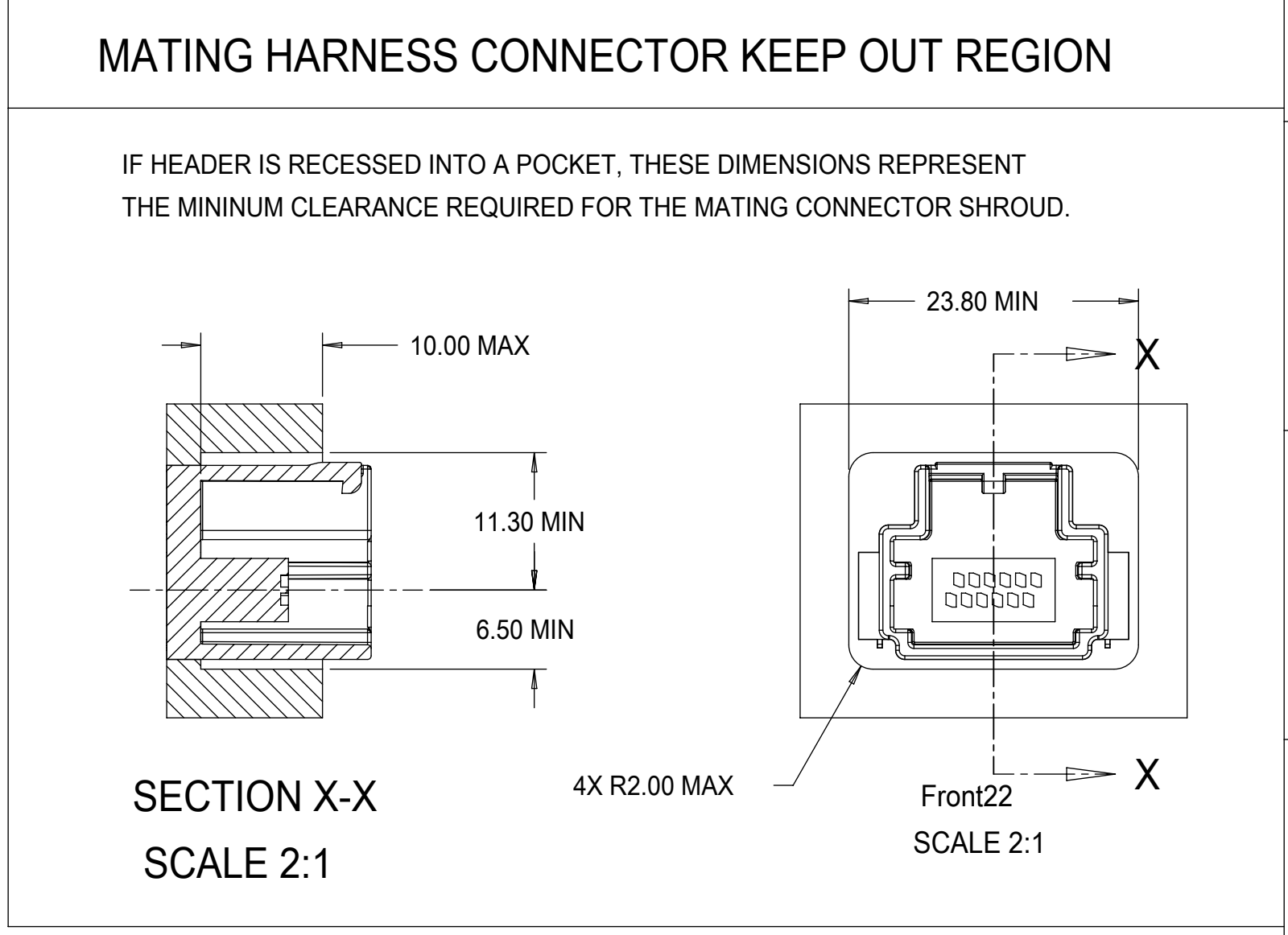
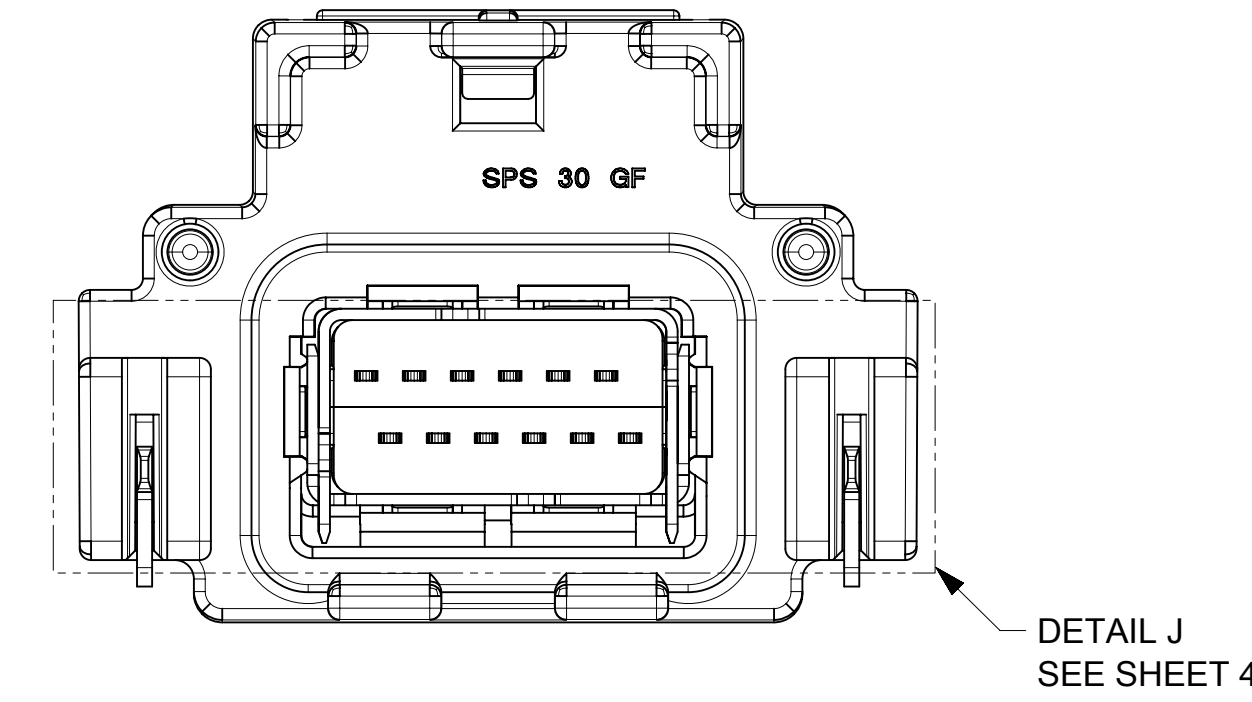
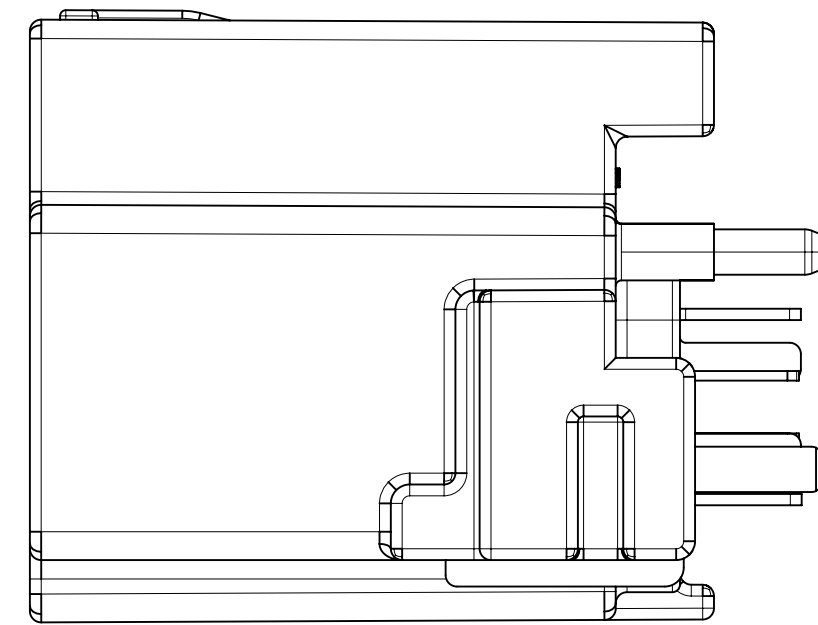
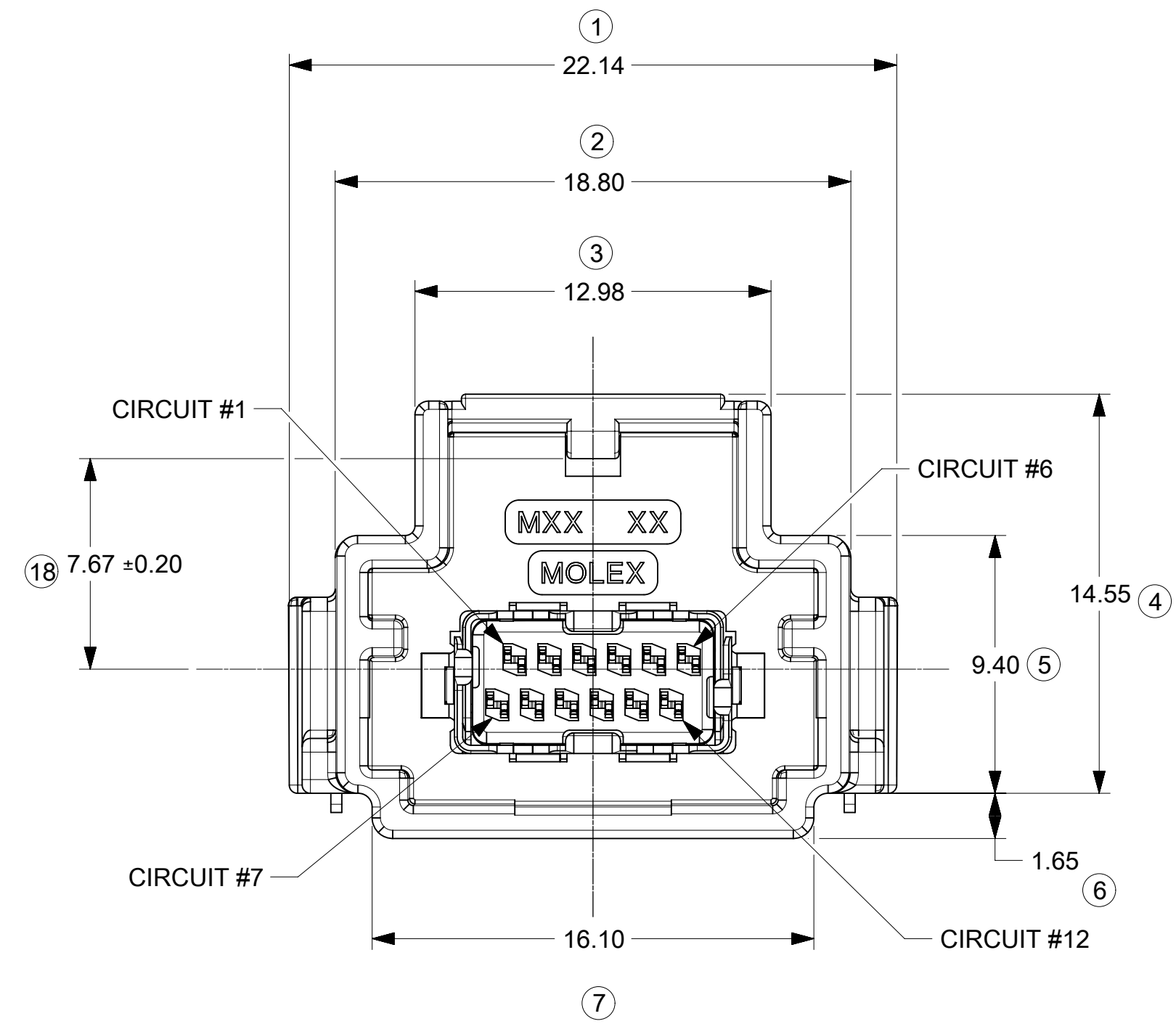

THESE SHIELD TABS ARE REMOVED ON 2 SHIELD TAB VERSION P/N: 34862-1306, 34862-1316, 34862-1326

THIS DRAWING CONTAINS INFORMATION THAT IS PROPRIETARY TO MOLEX ELECTRONIC TECHNOLOGIES, LLC AND SHOULD NOT BE USED WITHOUT WRITTEN PERMISSION											
DIMENSION UNITS		SCALE		CURRENT REV DESC:							
mm		5:1									
GENERAL TOLERANCES (UNLESS SPECIFIED)											
ANGULAR TOL ± °											
4 PLACES ±				EC NO: 686690							
3 PLACES ±				DRWN: PRAVEC2		2021/11/24					
2 PLACES ± 0.13				CHK'D: SMAMIDINAGAV		2021/12/09					
1 PLACE ± 0.25				APPR: SMAMIDINAGAV		2021/12/09					
0 PLACES ±				INITIAL REVISION:							
DRAFT WHERE APPLICABLE MUST REMAIN WITHIN DIMENSIONS		THIRD ANGLE PROJECTION		DRAWING		SERIES		MATERIAL NUMBER		CUSTOMER	
		D-SIZE		34862		SEE SHEET 1		GENERAL MARKET		3 OF 4	

molex

12 CKT HSAUTOLINK II VERTICAL HEADER
VERTICAL UNSEALED HEADER ASSEMBLY

PRODUCT CUSTOMER DRAWING

DOCUMENT NUMBER	DOC TYPE	DOC PART	REVISION
348621406	PSD	000	C2

DOCUMENT STATUS	P1	RELEASE DATE	2021/12/09 16:26:33
-----------------	----	--------------	---------------------

SHEET DESCRIPTION
RECOMMENDED PCB LAYOUT

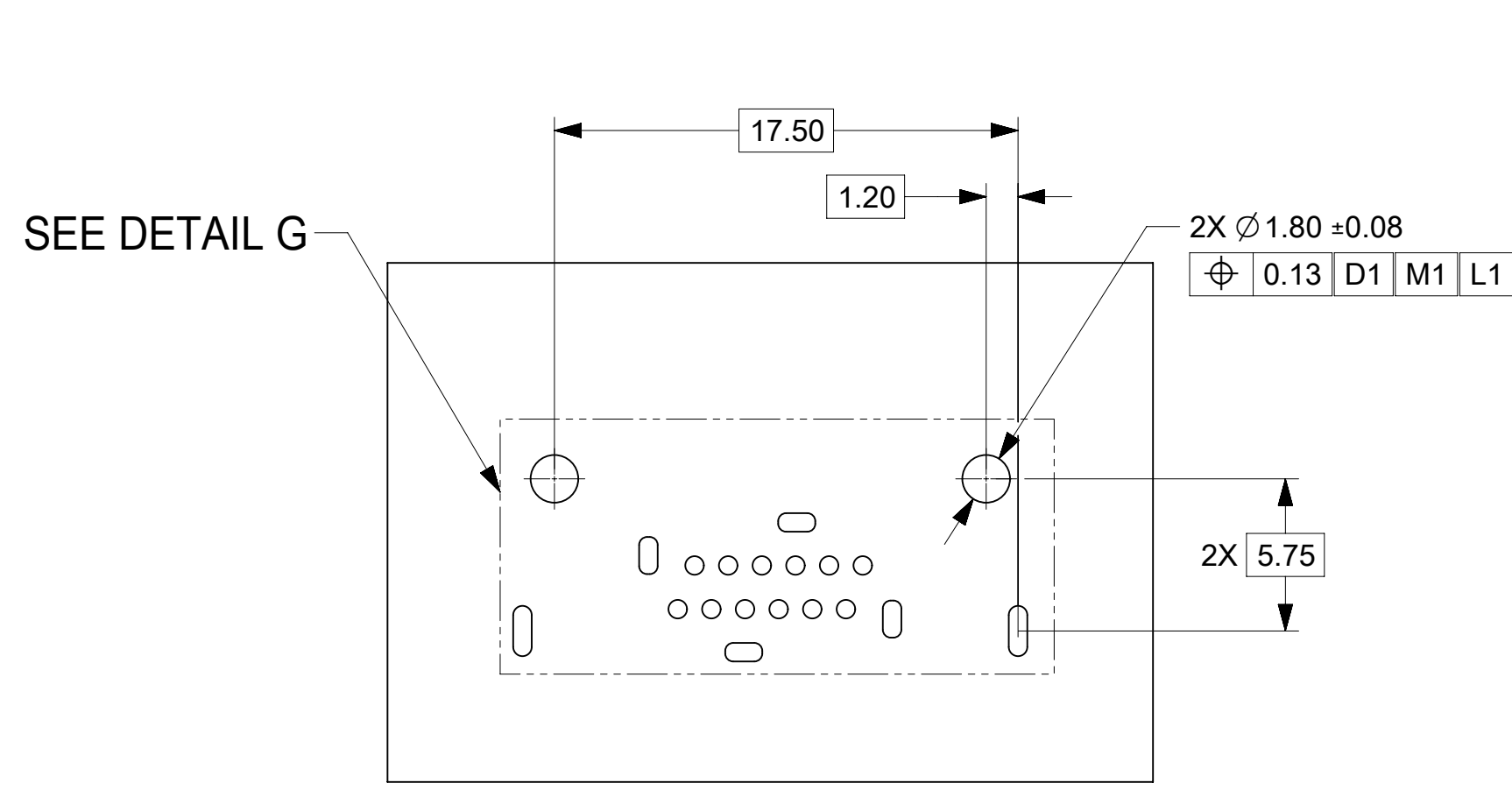

PCB KEYING
KEY OPTION 'A'

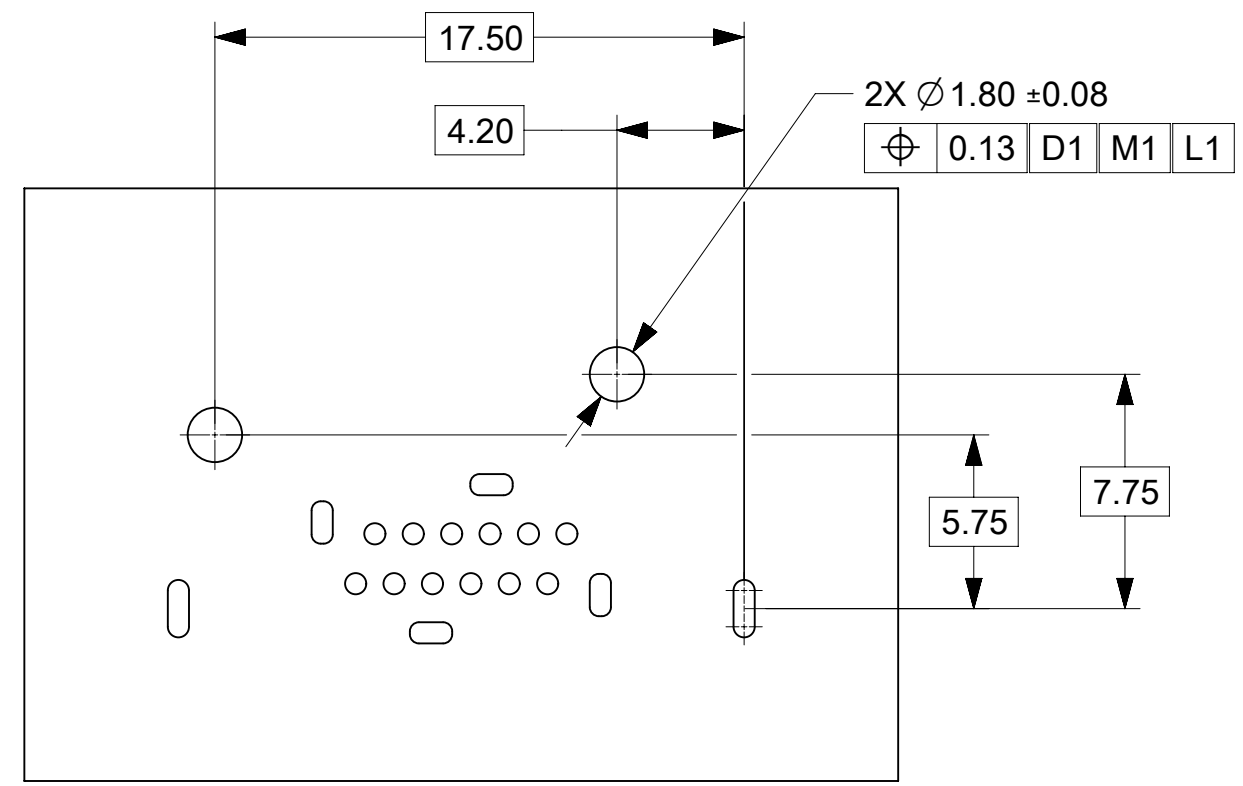

PCB KEYING
KEY OPTION 'B'

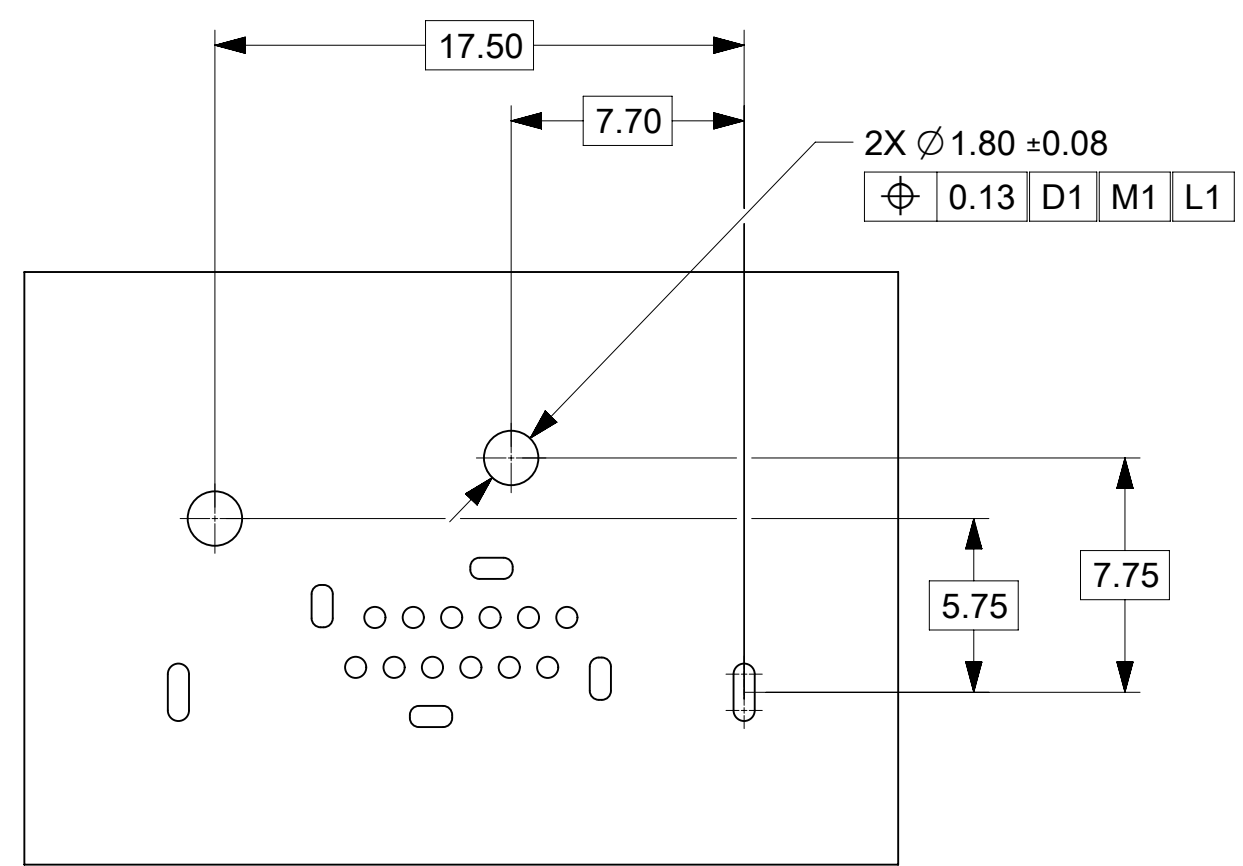

PCB KEYING
KEY OPTION 'C'

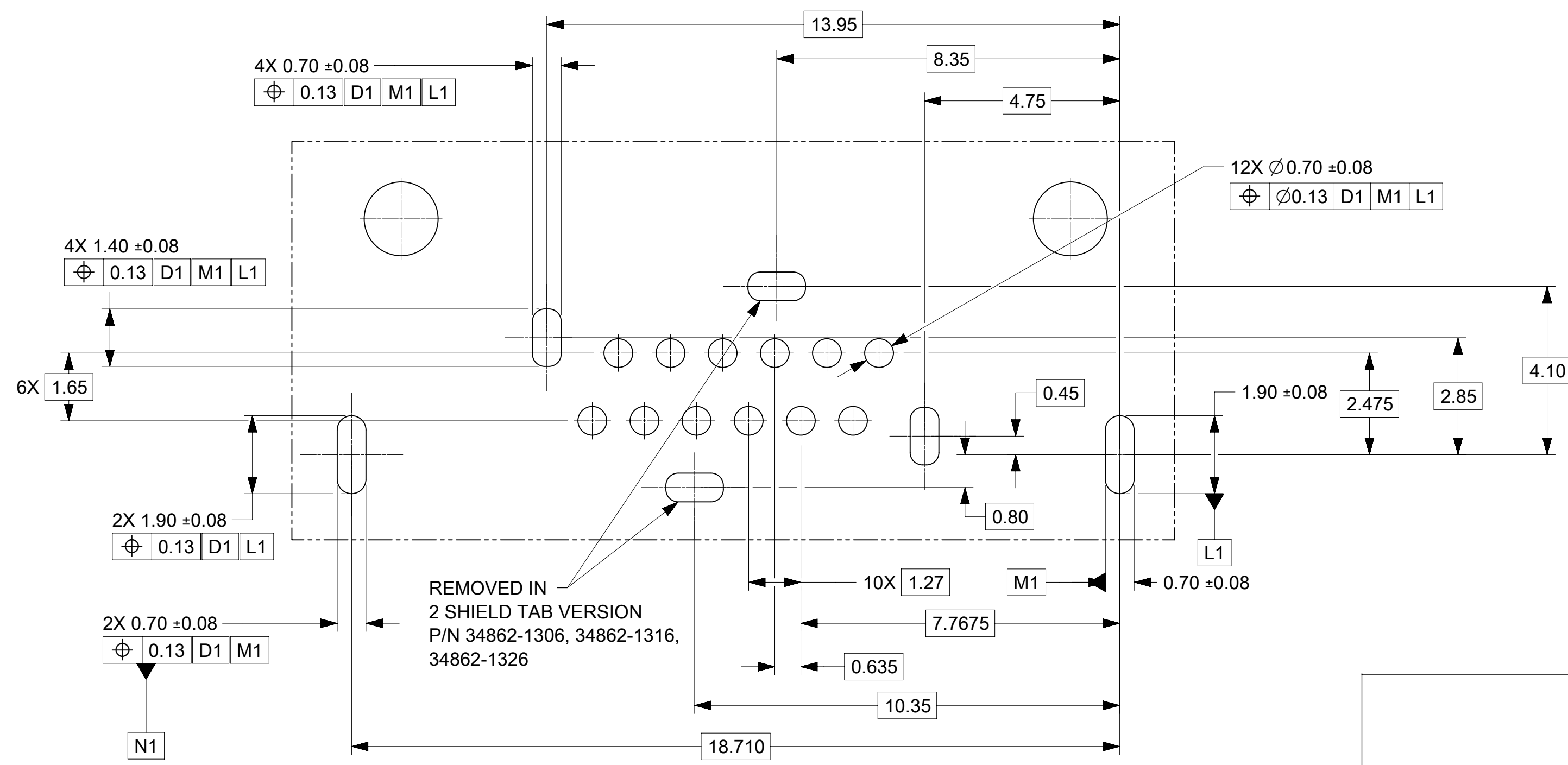

DETAIL G
SCALE 10:1

SOLDER TAILS SIZE
FOR REFERENCE ONLY

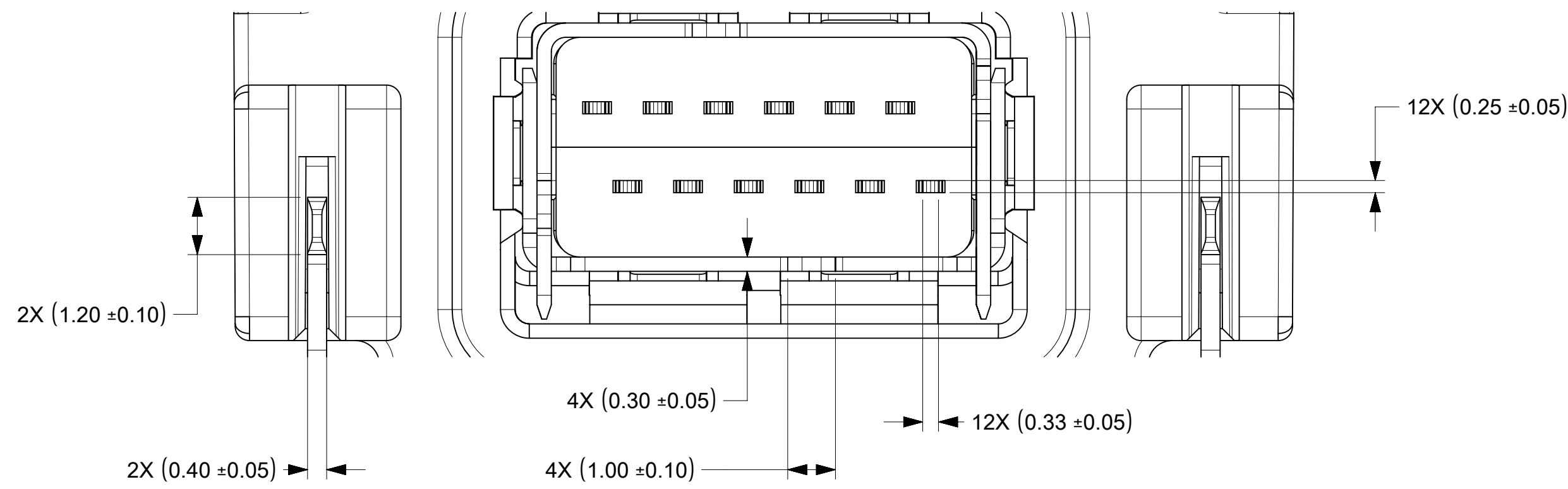

DETAIL J
SCALE 10:1

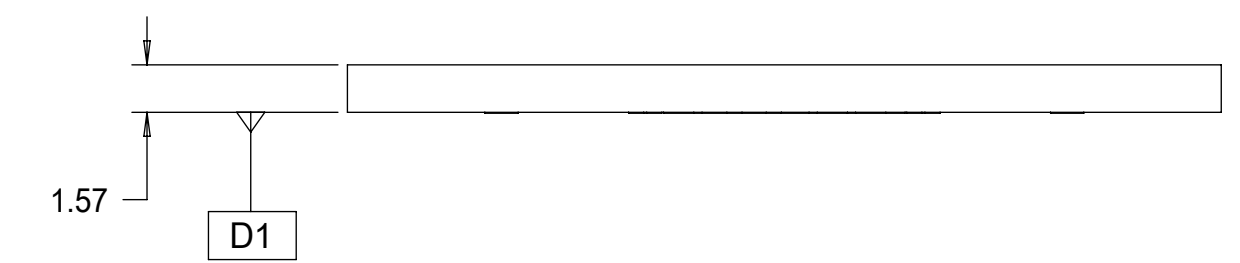
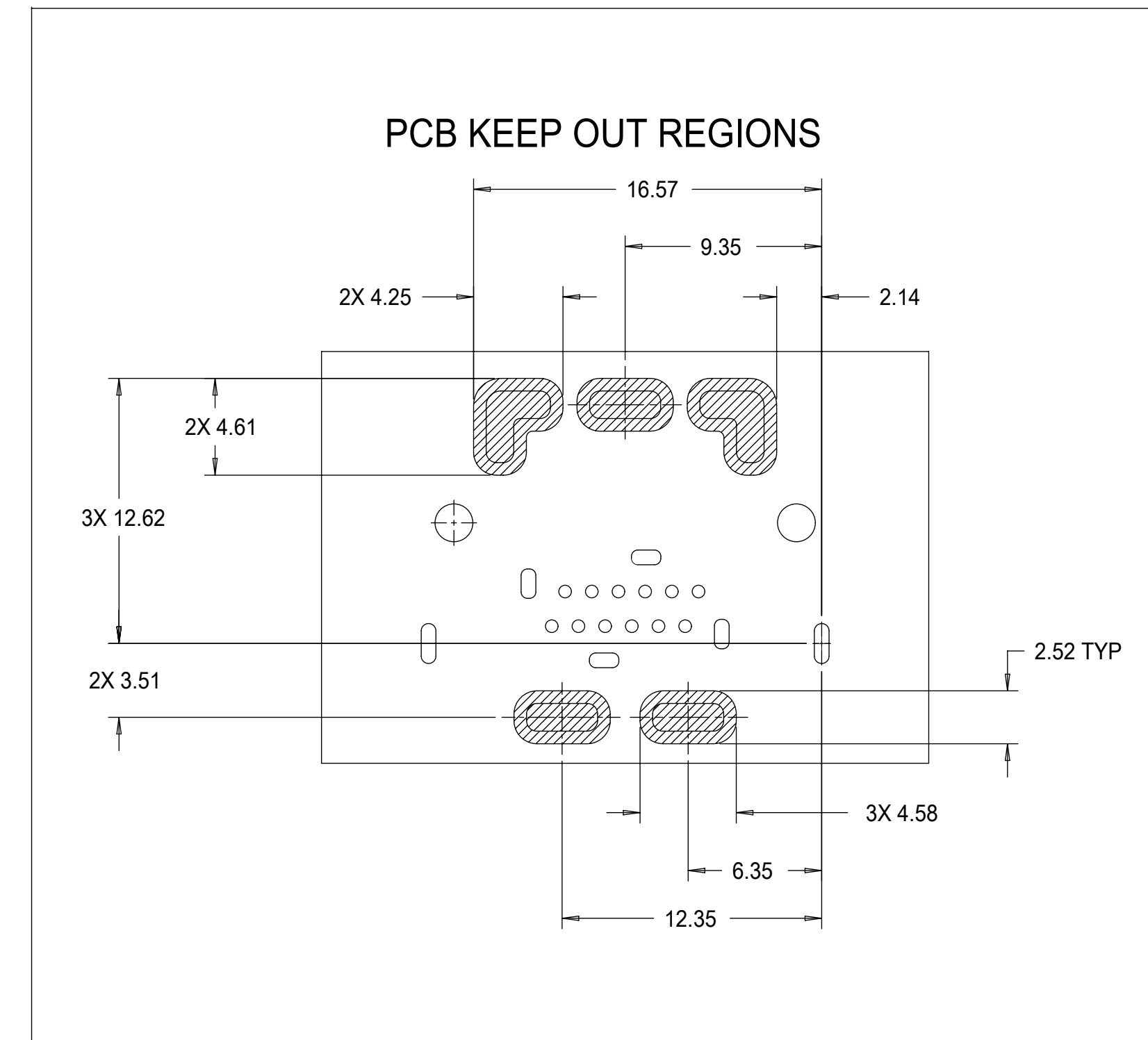

THIS DRAWING CONTAINS INFORMATION THAT IS PROPRIETARY TO MOLEX ELECTRONIC TECHNOLOGIES, LLC AND SHOULD NOT BE USED WITHOUT WRITTEN PERMISSION

DIMENSION UNITS	SCALE	CURRENT REV DESC:		molex		
mm	4:1			12 CKT HSAUTOLINK II VERTICAL HEADER VERTICAL UNSEALED HEADER ASSEMBLY		
GENERAL TOLERANCES (UNLESS SPECIFIED)		EC NO: 686690		PRODUCT CUSTOMER DRAWING		
ANGULAR TOL	± °	DRWN: PRAVEC2	2021/11/24	DOCUMENT NUMBER		
4 PLACES	±	CHK'D: SMAMIDINAGAV	2021/12/09	DOC TYPE DOC PART REVISION		
3 PLACES	±	APPR: SMAMIDINAGAV	2021/12/09	348621406 PSD 000 C2		
2 PLACES	± 0.13	INITIAL REVISION:		MATERIAL NUMBER CUSTOMER		
1 PLACE	± 0.25	DRWN: XLHE14	2018/06/25	SEE SHEET 1 GENERAL MARKET		
0 PLACES	±	APPR: DNAYLIS	2018/06/27	SHEET NUMBER		
DRAFT WHERE APPLICABLE MUST REMAIN WITHIN DIMENSIONS		THIRD ANGLE PROJECTION	DRAWING	SERIES	SHEET NUMBER	
			D-SIZE	34862	4 OF 4	