

EXAMPLE:
 PN 2075874081
 207587 - SERIES NUMBER: RECEPTACLE (PSA) / CPA ASSEMBLY
 4 - TYPE OF COMPONENT: LAST 2CKT DEPOPULATED (ERGO CPA)
 08 - 08 USABLE CIRCUITS
 1 - KEY A
 FINAL PART: 08CKT RECT/ERGO CPA ASSY (PSA) - KEY A

**RECEPTACLE
 8CKT WITH CPA SHOWN:**

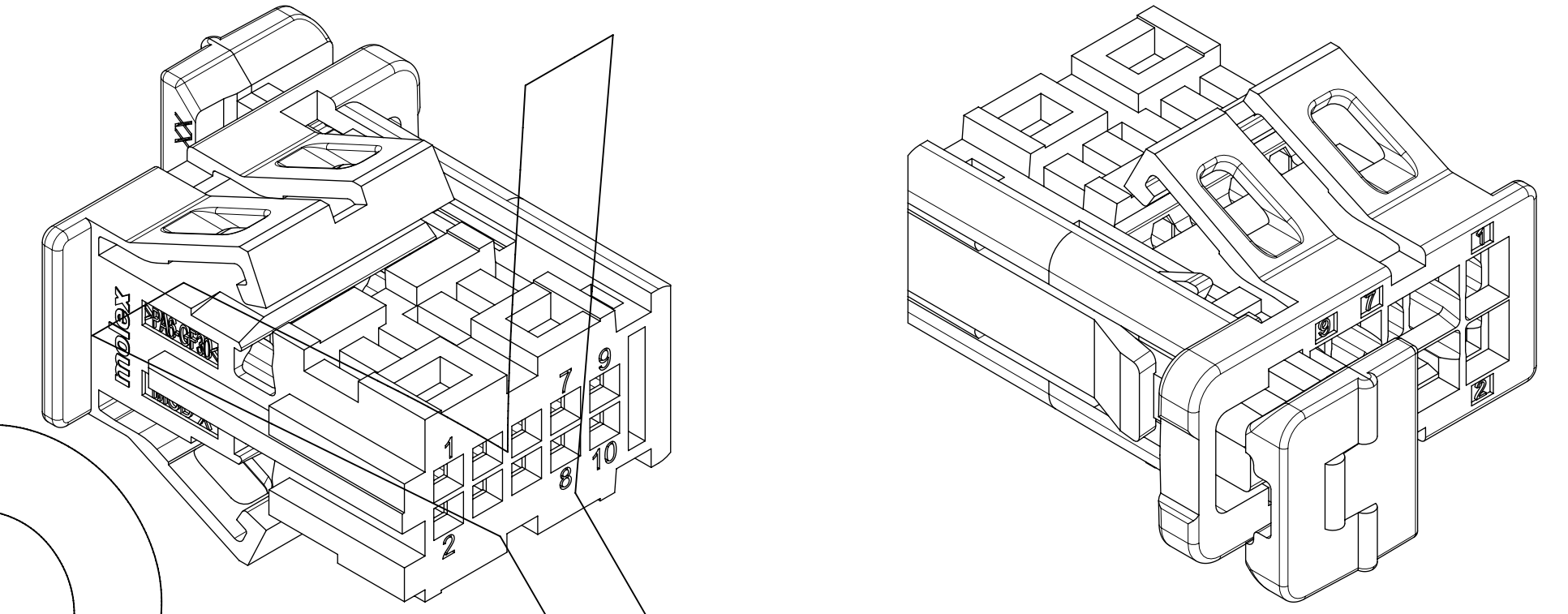

	SERIES NUMBERS (AAAAAA)	TYPE OF COMPONENT (B)	USABLE CIRCUITS (CC)	KEY (D)
ON DRAWING	207587 - DR RECEPTACLE (PSA) / ERGONOMIC CPA ASSEMBLY		02 - 2 Circuits	0 - KEY Z (NO KEY)
MATING PARTS	206958 - DR RIGHT ANGLE STANDARD PERFORMANCE SMT HEADER - TAPE & REEL	2 - STD MATL; NO CPA (ALL CIRCUITS USABLE) 4 - STD MATL; WITH CPA (LAST 2 CKTS UNUSABLE)	...	1 - KEY A
	206957 - DR VERTICAL STANDARD PERFORMANCE SMT HEADER - TAPE & REEL		2 - KEY B	
OTHER PARTS	205825 - DR RECEPTACLE (GENERAL MARKET)		...	3 - KEY C
	205826 - DR RECEPTACLE / CPA ASSEMBLY (GENERAL MARKET)		22 - 22 Circuits	4 - KEY D

* NOT FOR USE WITH PSA. SEE DRAWING 2058250002 FOR PART DETAILS.

INTERFACE	INTERFACE CKT SIZE	DIM A	DIM B	DIM C	KEY	COLOR	RECEPTACLE WITH ERGO CPA		PART STATUS
							PART NUMBER	USABLE CIRCUITS	
	4	10.56	7.48	0.20	Z	LIGHT BLUE	2075874020	2	INQUIRE FOR AVAILABILITY
					A	BLACK	2075874021	2	
					B	GREY	2075874022	2	
					C	BLUE	2075874023	2	
	6	12.36	9.28	1.10	Z	LIGHT BLUE	2075874040	4	INQUIRE FOR AVAILABILITY
					A	BLACK	2075874041	4	
					B	GREY	2075874042	4	
					C	BLUE	2075874043	4	
	8	14.16	11.08	2.00	Z	LIGHT BLUE	2075874060	6	INQUIRE FOR AVAILABILITY
					A	BLACK	2075874061	6	
					B	GREY	2075874062	6	
					C	BLUE	2075874063	6	
	10	15.96	12.88	2.90	Z	LIGHT BLUE	2075874080	8	AVAILABLE
					A	BLACK	2075874081	8	
					B	GREY	2075874082	8	
					C	BLUE	2075874083	8	
	12	17.78	14.68	3.80	Z	LIGHT BLUE	2075874100	10	INQUIRE FOR AVAILABILITY
					A	BLACK	2075874101	10	
					B	GREY	2075874102	10	
					C	BLUE	2075874103	10	
	14	19.66	16.48	4.70	Z	LIGHT BLUE	2075874120	12	INQUIRE FOR AVAILABILITY
					A	BLACK	2075874121	12	
					B	GREY	2075874122	12	
					C	BLUE	2075874123	12	
	16	21.36	18.28	5.60	Z	LIGHT BLUE	2075874140	14	INQUIRE FOR AVAILABILITY
					A	BLACK	2075874141	14	
					B	GREY	2075874142	14	
					C	BLUE	2075874143	14	
	18	23.16	20.08	6.50	Z	LIGHT BLUE	2075874160	16	INQUIRE FOR AVAILABILITY
					A	BLACK	2075874161	16	
					B	GREY	2075874162	16	
					C	BLUE	2075874163	16	
	20	24.96	21.88	7.40	Z	LIGHT BLUE	2075874180	18	INQUIRE FOR AVAILABILITY
					A	BLACK	2075874181	18	
					B	GREY	2075874182	18	
					C	BLUE	2075874183	18	
	22	26.76	23.68	8.30	Z	LIGHT BLUE	2075874200	20	INQUIRE FOR AVAILABILITY
					A	BLACK	2075874201	20	
					B	GREY	2075874202	20	
					C	BLUE	2075874203	20	
					D	VIOLET	2075874204	20	

STOR

B RAISED LATCH ADDED; CPA TYPE CHANGE; CPA MAX DIMENSIONS ADJUSTED; BALLOON NUMBERS ADDED; NOTES MODIFIED; CPA COLOR CHANGE; PN ADDED TO LASER MARK; DIM A SIZE INCREASE; ADDED NOTE 1.8; INTERNAL GEOMETRY CHANGES; REMOVED NO CPA PART NUMBERS; RENUMBERED DIMENSIONS
 A3 ADDED PRODUCT & APP. SPEC NUMBER; ADDED PACKAGING DRAWING NUMBER
 REV DESCRIPTION

THIS DRAWING CONTAINS INFORMATION THAT IS PROPRIETARY TO MOLEX ELECTRONIC TECHNOLOGIES, LLC AND SHOULD NOT BE USED WITHOUT WRITTEN PERMISSION

DIMENSION UNITS	SCALE	CURRENT REV DESC: SEE REV TABLE	
mm	5:1		
GENERAL TOLERANCES (UNLESS SPECIFIED)		EC NO: 652948	
ANGULAR TOL	± 5.0°	DRWN: ECOLARUSSO	2019/03/12
4 PLACES	± 0.0005	CHK'D: VBALASUBRAMA	2021/01/12
3 PLACES	± 0.005	APPR: JDUNAJ	2021/01/12
2 PLACES	± 0.05	INITIAL REVISION:	
1 PLACE	± 0.1	DRWN: ECOLARUSSO	2018/04/03
0 PLACES	± 1.0	APPR: JDUNAJ	2018/04/11
DRAFT WHERE APPLICABLE MUST REMAIN WITHIN DIMENSIONS	THIRD ANGLE PROJECTION	DRAWING	SERIES
		D-SIZE	207586
MATERIAL NUMBER		CUSTOMER	SHEET NUMBER
2075860002		PSA	1 OF 2

INSPECTION BALLOON NUMBER LOG
 PER DRAWING REVISION: B
 LAST BALLOON USED: 22
 ADDED BALLOON NUMBERS:
 REMOVED BALLOON NUMBERS: 2

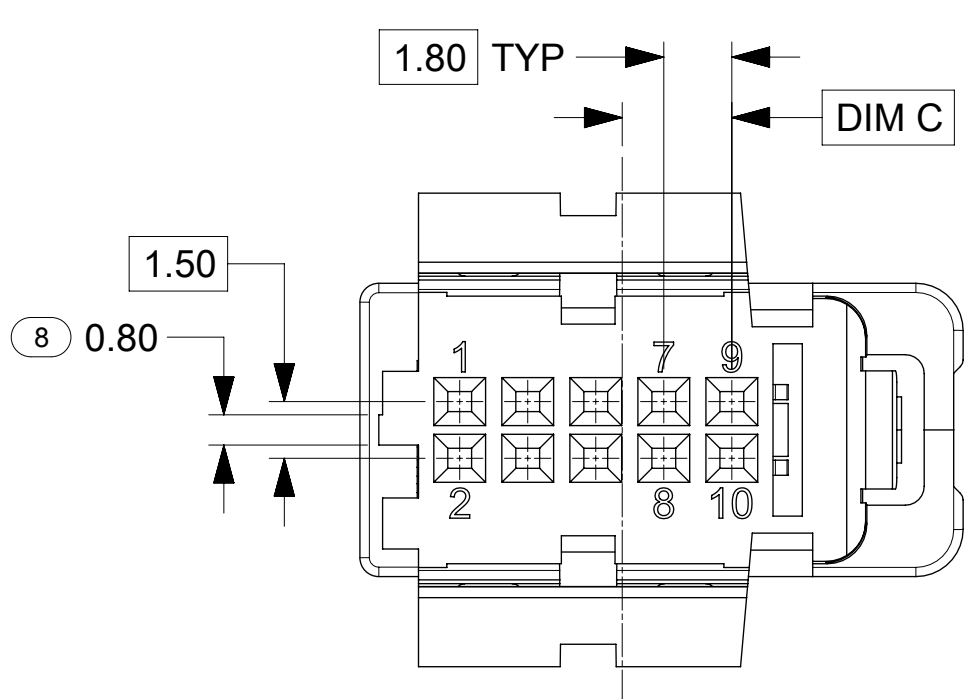
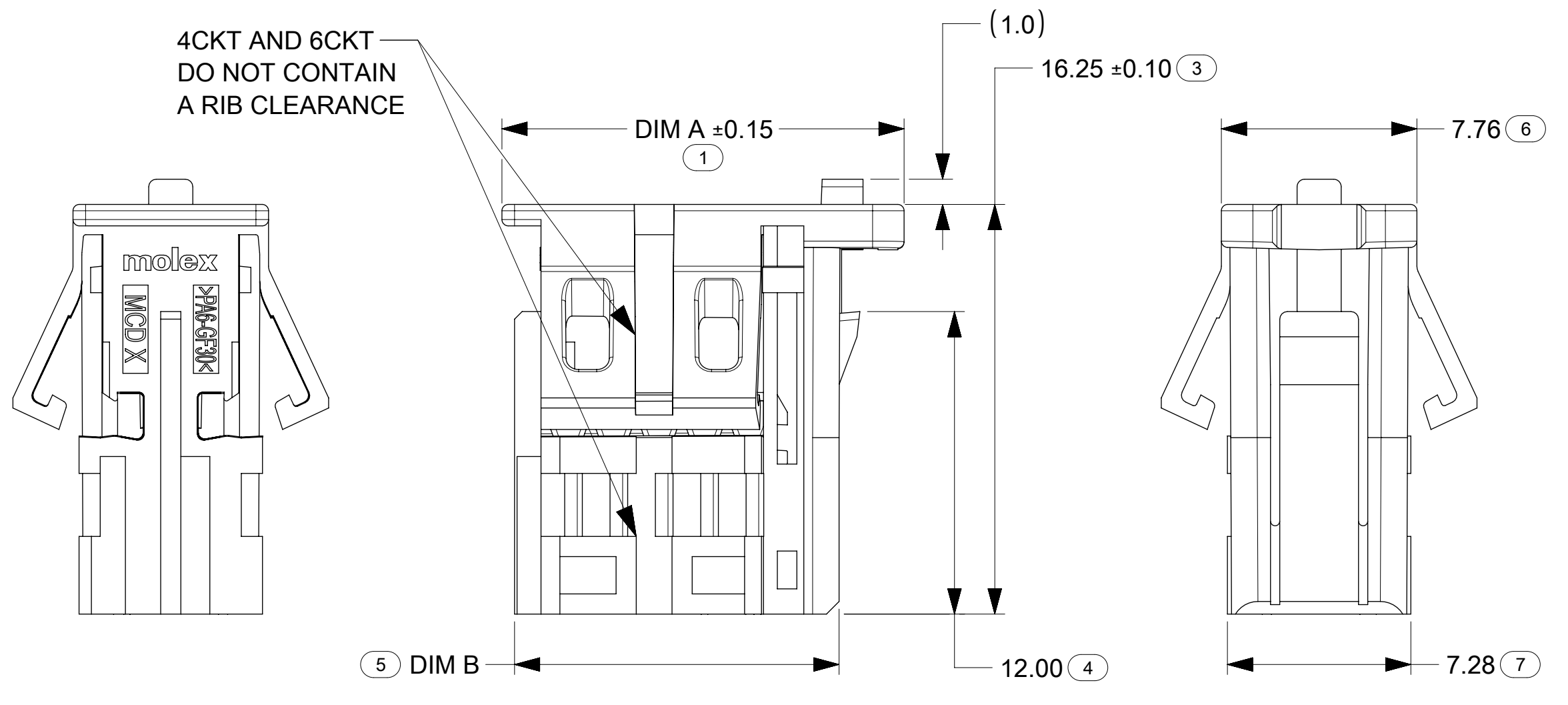

NOTES:
 VALID UNLESS OTHERWISE SPECIFIED

1. GENERAL:

- 1.1 APPLICATION SPECIFICATION SEE: 2075870011-RAS
- 1.2 PRODUCT SPECIFICATION SEE: 2046310000-PS
- 1.3 PACKAGING SPECIFICATION PER MOLEX DRAWING: PK-31301-695
- 1.4 THE MAXIMUM USABLE CIRCUITS WHEN USING THE ERGO CPA
- 1.5 COMPATIBLE WITH STANDARD AK INTERFACE DRAWING C-114-94000-20 REV A1
- 1.6 COMPATIBLE WITH PSA INTERFACE DRAWING R001381068 REV D
- 1.7 COMPATIBLE WITH MOLEX AK INTERFACE 2046310002 REV A
- 1.8 TOLERANCES APPLY IN DRY AS MOLDED STATE ONLY

2. DESIGN - MATERIALS:

2.1 RECEPTACLE HOUSING:

- A. MATERIAL: PA6-GF30%
- B. COLOR: SEE PART TABLE

2.2 CPA

- A. MATERIAL: PA6-GF30%
- B. COLOR: RED

3. DESIGN - GEOMETRY:

- 3.1 GEOMETRIC DIMENSIONS AND TOLERANCES PER ASME Y14.5-2018
- 3.2 EDGES AND UNDIMENSIONED DETAILS PER ISO13715
- 3.3 CORNERS SHOWN AS SHARP TO BE R 0.2 MAX.
- 3.4 MARKED TEXT TO INCLUDE:
 - A. FOR RECEPTACLE COMPONENT: RECYCLING CODE, CAVITY ID, AND VENDOR IDENTIFICATION.
 - B. FOR ASSEMBLY ONLY: LASER ETCHED DATE CODE & PART NUMBER
 DATE CODE 1ST THROUGH 2ND DIGIT = CALENDAR YEAR
 DATE CODE 3RD THROUGH 5TH DIGIT = "DAY #" OF YEAR

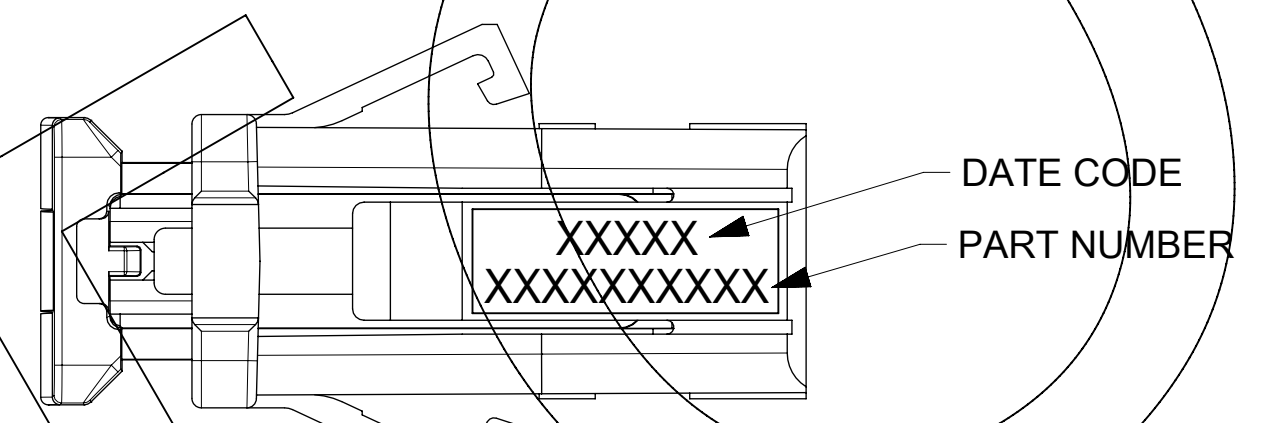

ERGONOMIC CPA:

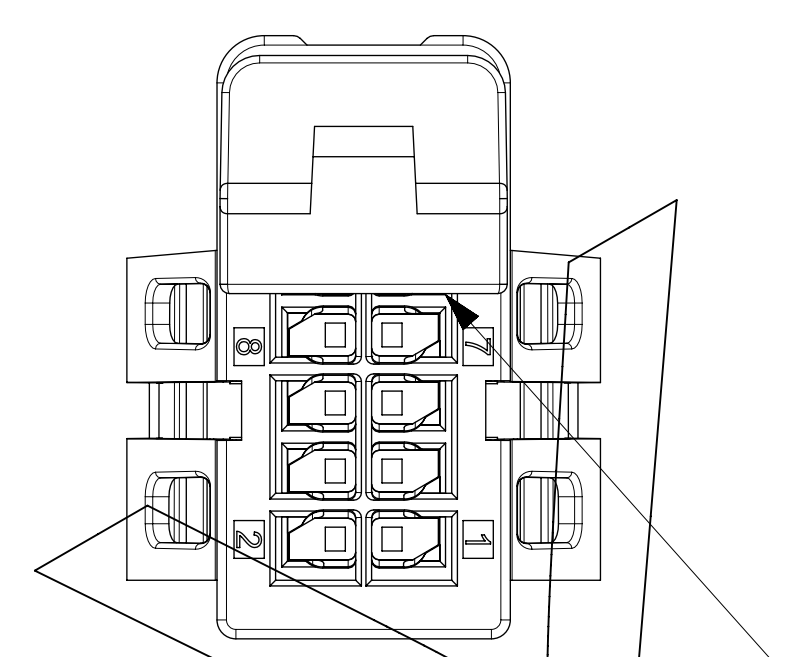

NOTE: 2 CIRCUITS UNAVAILABLE WHEN ERGO CPA IS USED

CPA IN PRE-LOCK (AS DELIVERED)

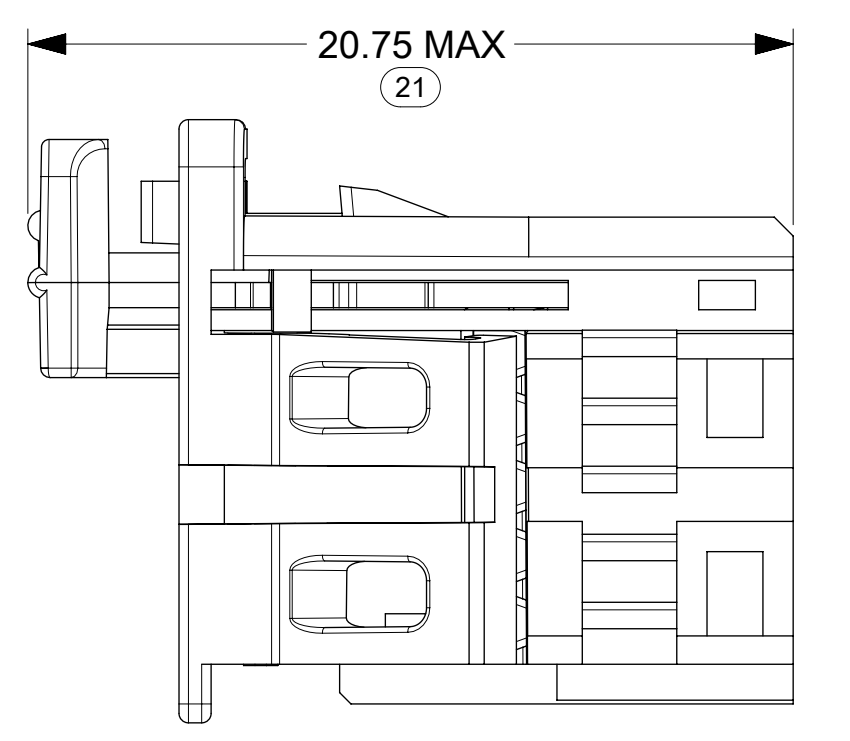

CPA IN FINAL LOCK

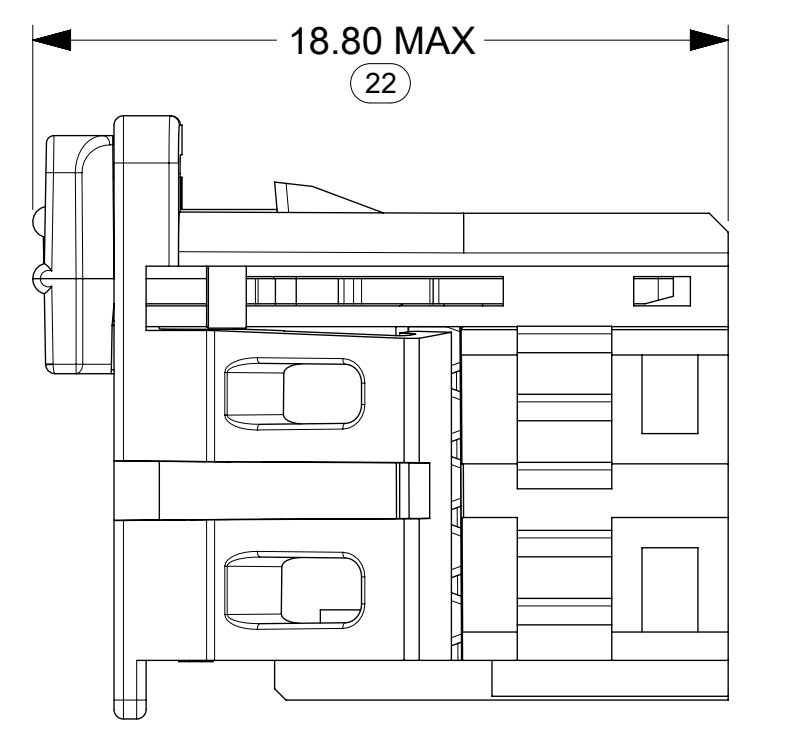

ISL IN FINAL LOCK

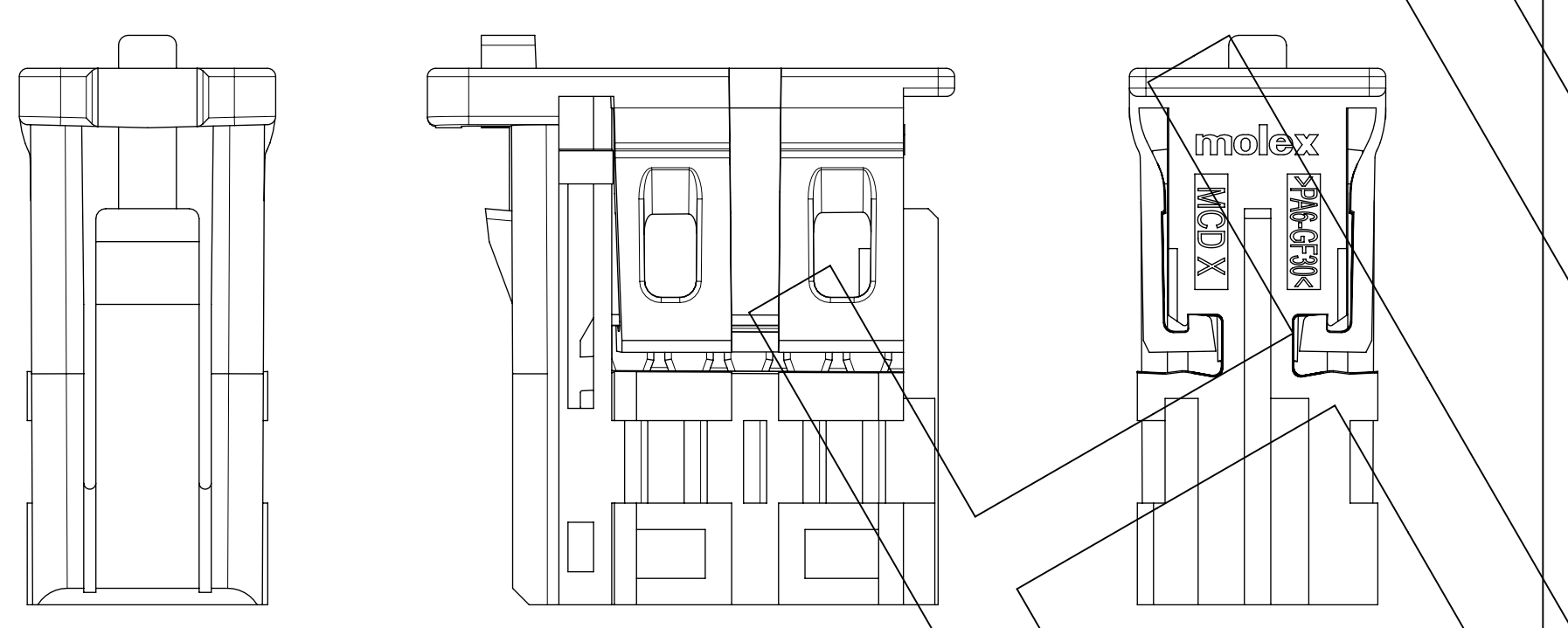

POLARIZATION / KEYS / CODING

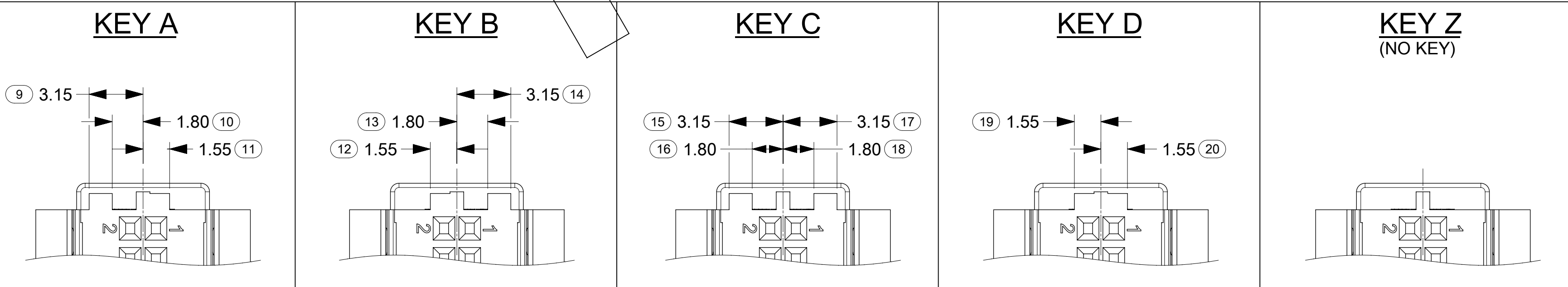

THIS DRAWING CONTAINS INFORMATION THAT IS PROPRIETARY TO MOLEX ELECTRONIC TECHNOLOGIES, LLC AND SHOULD NOT BE USED WITHOUT WRITTEN PERMISSION											
DIMENSION UNITS		SCALE		CURRENT REV DESC: SEE REV TABLE							
mm		5:1									
GENERAL TOLERANCES (UNLESS SPECIFIED)											
ANGULAR TOL ± 5.0°											
4 PLACES ± 0.0005											
3 PLACES ± 0.005											
2 PLACES ± 0.05											
1 PLACE ± 0.1											
0 PLACES ± 1.0											
DRAFT WHERE APPLICABLE MUST REMAIN WITHIN DIMENSIONS			THIRD ANGLE PROJECTION		DRAWING		SERIES		MATERIAL NUMBER		
			D-SIZE		207586		207586		SEE TABLE		
DOCUMENT STATUS				HI		RELEASE DATE		2021/09/08		19:32:33	
EC NO: 652948				DRWN: ECOLARUSSO		2019/03/12		CONNTAK50 (PSA) DUAL ROW RECEPTACLE & RECEPTACLE / CPA ASSEMBLY			
CHK'D: VBALASUBRAMA				2021/01/12		APPR: JDUNAJ		PRODUCT CUSTOMER DRAWING			
INITIAL REVISION:				DRWN: ECOLARUSSO		2018/04/03		DOCUMENT NUMBER			
APPR: JDUNAJ				2018/04/11		2075860002		DOC TYPE		DOC PART	
				PSD		000		REVISION		B	
DRAFT WHERE APPLICABLE MUST REMAIN WITHIN DIMENSIONS				THIRD ANGLE PROJECTION		DRAWING		SERIES		MATERIAL NUMBER	
				D-SIZE		207586		CUSTOMER		SHEET NUMBER	
						PSA				2 OF 2	