

NOTES

1. GENERAL:

- 1.1. ALL PRODUCT SPECIFICATIONS AND THEIR RELATED DOCUMENTS USING THIS FEATURE MUST REFERENCE THIS DOCUMENT AS THE CONTROLLING SPECIFICATION AND USE THE SAME BALLOON NUMBERS.
- 1.2. COMPLIANCY TO THIS DOCUMENT:
 - a) COMPLIANCY MAY BE CLAIMED BY MEETING THE REQUIREMENTS IN THIS SPECIFICATION WITH THE DEVIATION IDENTIFIED AND MAY BE REFERENCED IN OTHER DOCUMENTS (DRAWINGS, DVP&R, ETC.) AS 'CONFORMS TO MOLEX 347350050 REV X.X'.
 - b) PRODUCTS DESIGNED AFTER THE DATE OF RELEASE OF THIS DOCUMENT SHALL BE COMPLIANT TO THE CURRENT REVISION OF THIS DOCUMENT.
 - c) PRODUCTS THAT HAVE MET PREVIOUS REVISION(S) OF THIS DOCUMENT SPECIFICATION SHALL STILL BE CONSIDERED 'MOLEX STANDARDS COMPLIANT' TO THOSE REVISIONS AND DO NOT NEED TO BE RE-VALIDATED.
- 1.3. DEVIATIONS TO THIS DOCUMENT ARE ALLOWABLE UNDER THE FOLLOWING CONDITIONS:
 - a) ALL DEVIATIONS SHALL SHOW EQUAL OR BETTER PERFORMANCE (ELECTRICAL/MECHANICAL) AS REQUIRED BY VALIDATION SPECIFICATION.
 - b) EXCEPTIONS ARE CLEARLY IDENTIFIED ON THE PRODUCT SPECIFICATION.
 - c) ALL DEVIATIONS ARE APPROVED BY THE FOLLOWING INDIVIDUALS:
 - PERSON WHO HAS INTERFACE RESPONSIBILITY
 - PERSON WITH DESIGN STANDARD APPROVER AUTHORITY
 - d) ALL RECORDS OF DEVIATION APPROVALS SHALL BE INCLUDED WITH CHANGE NOTICE DOCUMENTATION.

2. DESIGN - MATERIALS:

- 2.1. BASE MATERIAL TYPE : COPPER ALLOY

3. DESIGN - GEOMETRY:

- 3.1. THE 3-D CAD DATA IS BASIC (WITHOUT TOLERANCE) AND MASTER FOR THIS PART WITH EXCEPTION TO UNDERLINED DIMENSIONS. DIMENSIONAL INFORMATION NOT SHOWN ON THIS DRAWING IS DEFINED BY THE DATA FILE AT ITS LATEST REVISION.
- 3.2. PRODUCT DESIGN MODEL NUMBER(S): SEE BOM TABLE
- 3.3. GEOMETRIC DIMENSIONS AND TOLERANCES PER ASME Y14.5-2009
- 3.4. EDGES OF UNDEFINED SHAPE PER ISO 13715.
- 3.5. DIMENSIONS AND TOLERANCES APPLY BEFORE AND AFTER PLATING.
- 3.6. GENERAL TOLERANCES: SEE TITLE BLOCK

4. DESIGN - MANUFACTURING:

- 4.1. ANY REMAINING PROCESS LUBRICANT MUST NOT VARNISH OR DEGRADE ELECTRICAL PERFORMANCE. PROCESS LUBRICANTS SHOULD BE APPROVED BY THE RESPONSIBLE ENGINEER.
- 4.2. ALLOWABLE BURR: 0.03mm MAX UNLESS OTHERWISE SPECIFIED
- 4.3. FOR UNPLATES BLADES - TOOLING MARKS SPANNING ACROSS OR ALONG THE INTERFACING PROFILE OF THE BLADE SHOULD BE FURTHER INSPECTED. A TOOLING MARK DEEPER THAN 1 MICRON SHOULD NOT BE ACCEPTED.

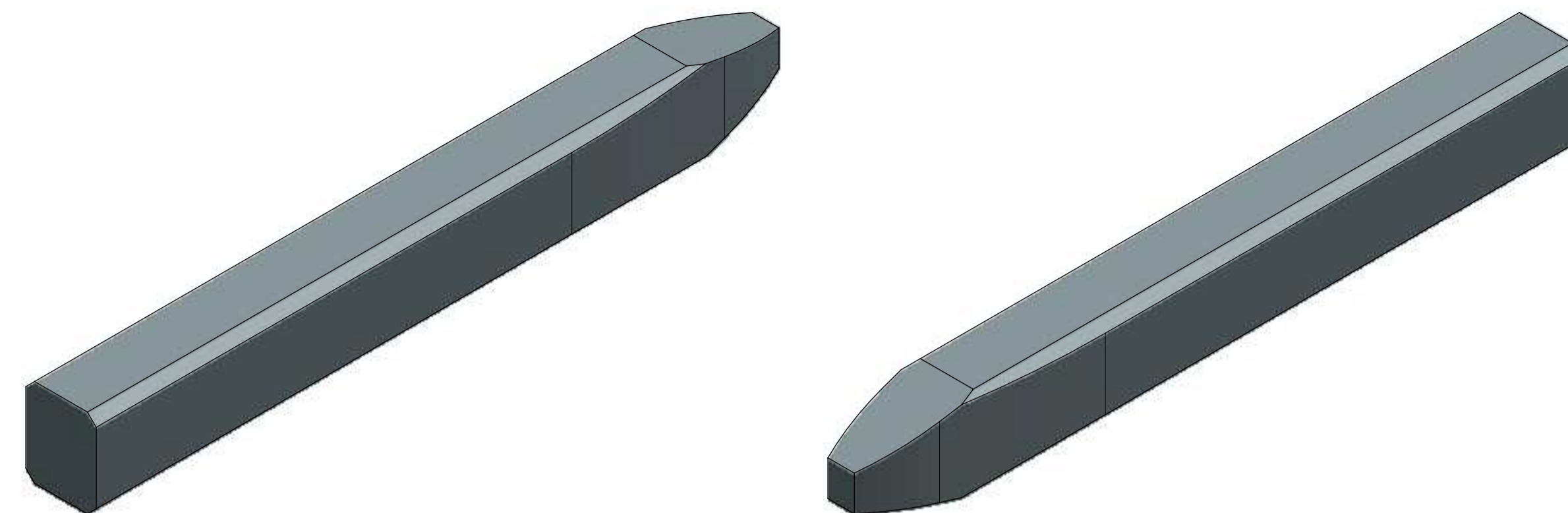

SCALE 50:1

0.5 MM PIN VIEW SHOWN FOR REPRESENTATION PURPOSES ONLY

THIS DRAWING CONTAINS INFORMATION THAT IS PROPRIETARY TO MOLEX ELECTRONIC TECHNOLOGIES, LLC AND SHOULD NOT BE USED WITHOUT WRITTEN PERMISSION											
QUALITY SYMBOLS	EC NO: 638183 DRWN: SJAZRAWI CHKD: YLEPOTTIER REV: APPR: YLEPOTTIER	2020/05/20 2020/05/23 2020/05/23		GENERAL TOLERANCES (UNLESS SPECIFIED)		DIMENSION UNITS mm		SCALE 50:1			
		ANGULAR TOL ± °		DRWN BY SJAZRAWI		DATE 2016/08/16					
▽ = 0	DRAFT WHERE APPLICABLE MUST REMAIN WITHIN DIMENSIONS	4 PLACES ±		CHK'D BY YLEPOTTIER		DATE 2016/09/27		PRODUCT CUSTOMER DRAWING		SERIES 34735	
▽ = 0		3 PLACES ± 0.015		APPR BY YLEPOTTIER		DATE 2016/09/27		MATERIAL NUMBER 347350050		CUSTOMER	
▽ = 0		2 PLACES ± 0.05		DRAWING SIZE A1		THIRD ANGLE PROJECTION		DOC TYPE PSD		DOC PART 000	
▽ = 0		1 PLACE ± 0.1		SHEET NUMBER 1 OF 2		SHEET NUMBER 1 OF 2		DOC PART 000		SHEET NUMBER 1 OF 2	
▽ = 0		0 PLACES ±		SHEET NUMBER 1 OF 2		SHEET NUMBER 1 OF 2		DOC PART 000		SHEET NUMBER 1 OF 2	
▽ = 0		0 PLACES ±		SHEET NUMBER 1 OF 2		SHEET NUMBER 1 OF 2		DOC PART 000		SHEET NUMBER 1 OF 2	

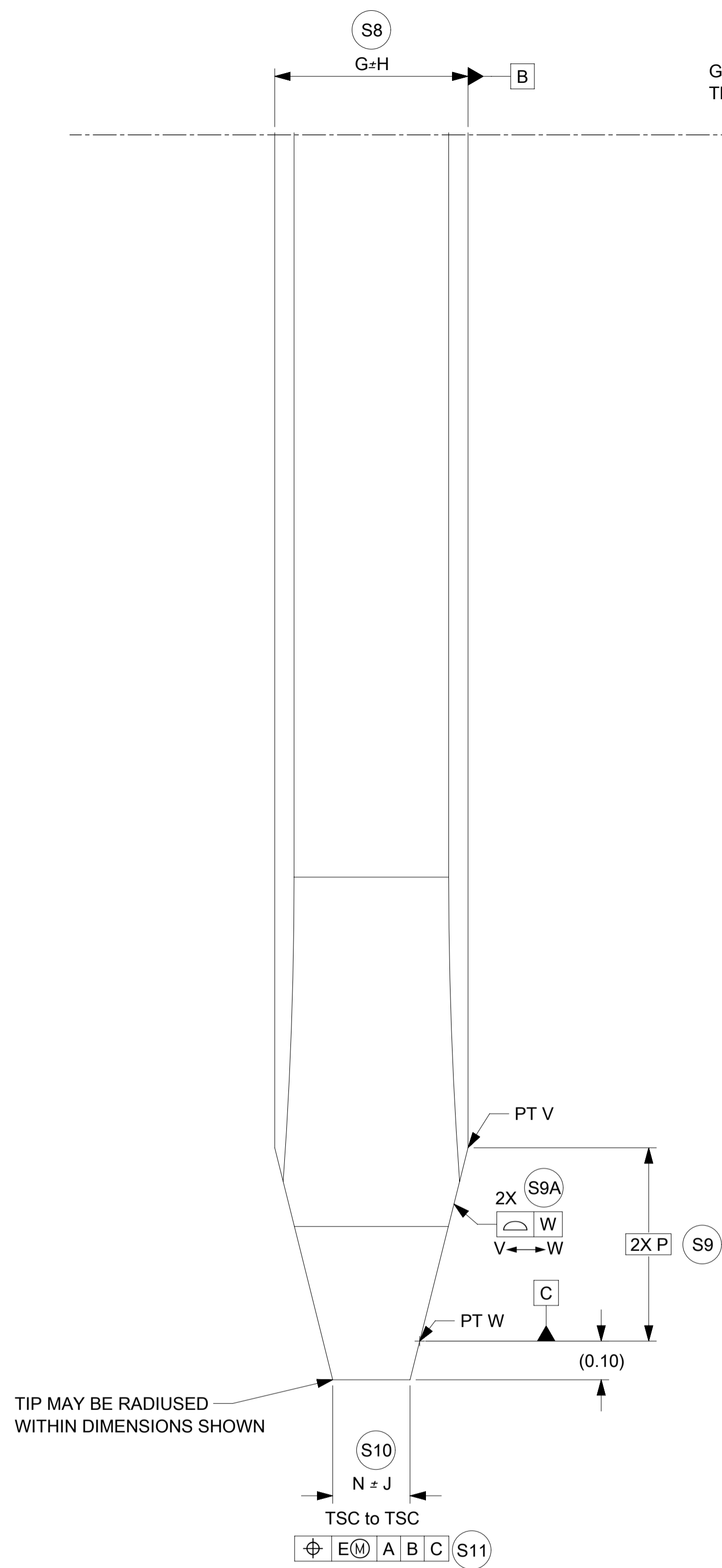

GEOMETRY & PLATING ABOVE THE LINE IS NOT CONTROLLED BY THIS DOCUMENT

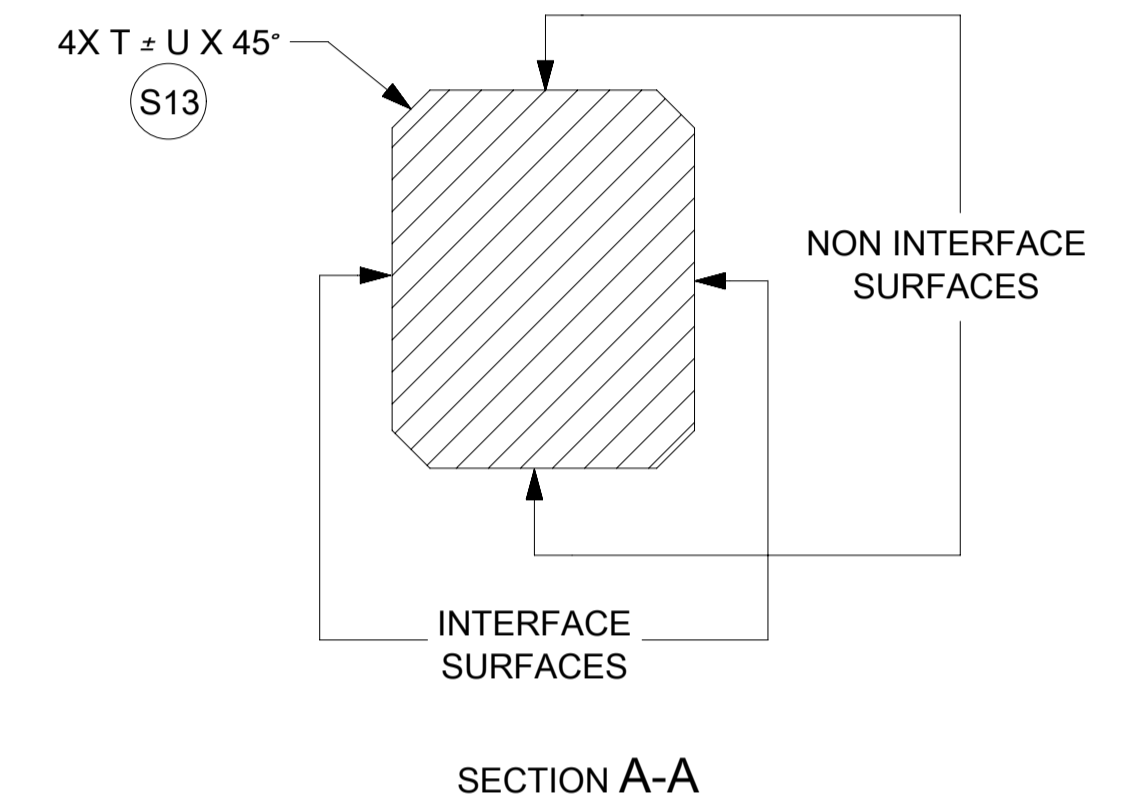
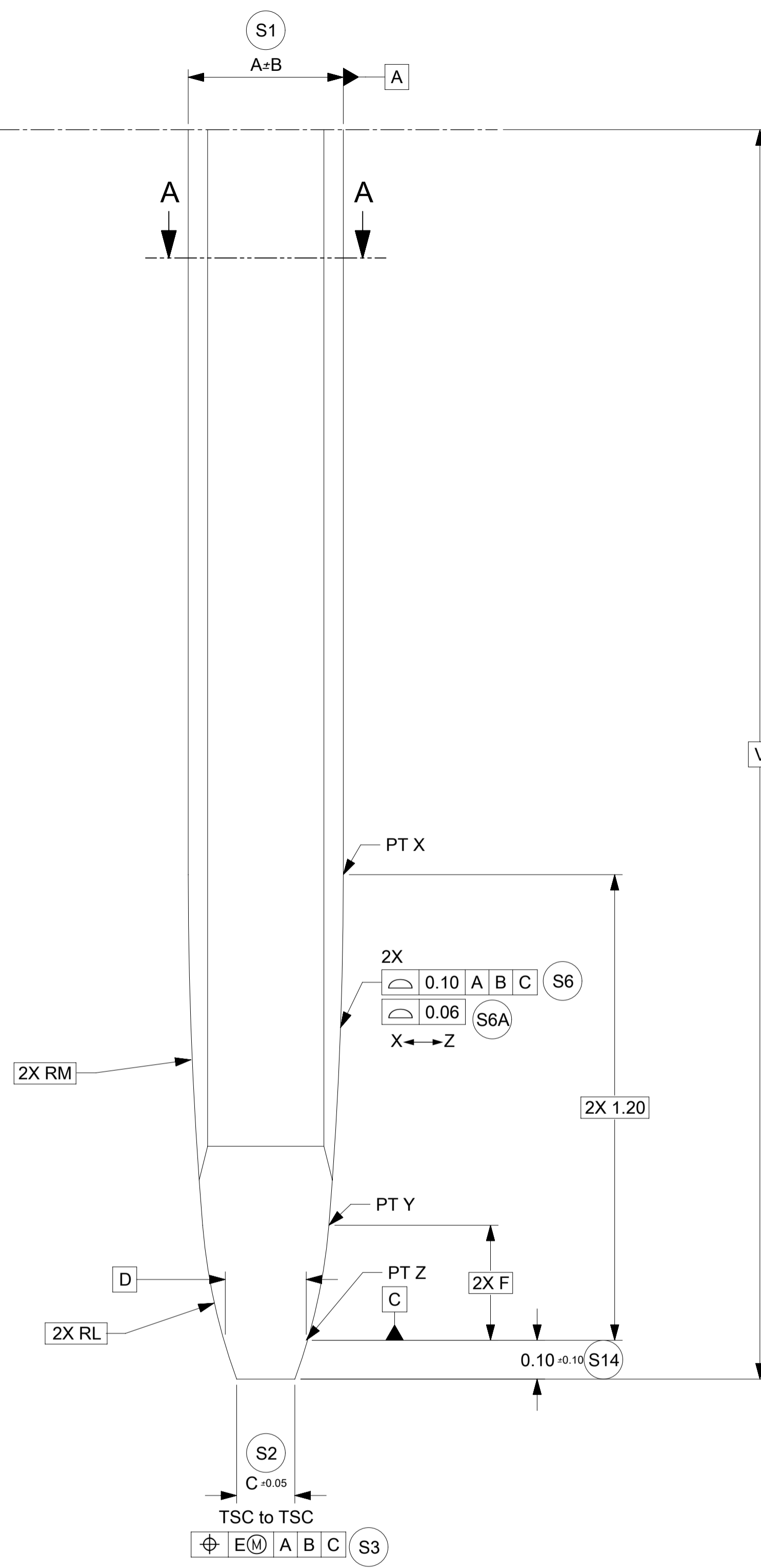

SCALE 100:1

TABLE 1		DRAWING DIMENSIONS																
Model NO.	Description	A	B	C	D	E	F	G	H	J	L	M	N	P	T	U	V	W
34735-0004	0.50mm BLADE	0.40	0.015	0.15	0.216	0.05	0.296	0.50	0.03	0.05	1.5	11	0.20	0.50	0.05	0.03	4.0 MIN	0.08
34735-0001	0.64mm BLADE - NORMAL THICKNESS	0.64	0.03	0.25	0.356	0.10	0.285	0.64	0.03	0.05	1	7	0.25	0.55	0.05	0.03	5.5 MIN	0.08
34735-0002	0.64mm BLADE - REDUCED THICKNESS	0.625	0.015	0.234	0.341	0.10	0.285	0.64	0.03	0.05	1	7	0.25	0.55	0.05	0.03	5.5 MIN	0.08
34735-0006	1.20mm BLADE - HEADER	0.60	0.015	0.21	0.316	0.10	0.285	1.00	0.05	0.05	1	7	0.59	0.55	0.05	0.03	5.5 MIN	0.13
34735-0006	1.20mm BLADE - INLINE	0.60	0.015	0.21	0.316	0.10	0.285	1.20	0.05	0.05	1	7	0.59	0.55	0.05	0.03	5.5 MIN	0.13
34735-0003	1.50mm BLADE	0.80	0.03	0.25	0.321	0.10	1.10	1.50	0.05	0.10	4.775	1.083	0.5	1.68	0.05	0.03	5.0 MIN	0.13
34735-0010	2.8mm BLADE - HEADER	0.80	0.025	0.20	0.345	0.10	0.314	2.50	0.10	0.10	1	4	1.80	1.10	0.05	0.03	9.5 MIN	0.25
34735-0011	6.3mm BLADE - HEADER	0.80	0.025	0.20	0.345	0.10	0.314	6.0	0.25	0.20	1	4	3.90	1.10	0.05	0.03	10.5 MIN	0.13

THIS DRAWING CONTAINS INFORMATION THAT IS PROPRIETARY TO MOLEX ELECTRONIC TECHNOLOGIES, LLC AND SHOULD NOT BE USED WITHOUT WRITTEN PERMISSION

QUALITY SYMBOLS F = 0 F = 0 F = 0 ▽ = 0 C = 0 ⊠ = 0 ■ = 0 ▽ = 0	EC NO: 638183 DRWN: SJAZRAWI CHKD: YLEPOTTIER APPR: YLEPOTTIER	2020/05/20 2020/05/23 2020/05/23	GENERAL TOLERANCES (UNLESS SPECIFIED) ANGULAR TOL ± ° 4 PLACES ± 3 PLACES ± 0.015 2 PLACES ± 0.05 1 PLACE ± 0.1 0 PLACES ± DRAFT WHERE APPLICABLE MUST REMAIN WITHIN DIMENSIONS	DIMENSION UNITS: mm SCALE: 100:1 DRWN BY: SJAZRAWI DATE: 2016/08/16 CHK'D BY: YLEPOTTIER DATE: 2016/09/27 APPR BY: YLEPOTTIER DATE: 2016/09/27 DRAWING SIZE: A1 THIRD ANGLE PROJECTION	
	DESIGN STANDARD HEADER PIN & BLADE TIP GEOMETRY FOR MATING TO HARNESS TERMINALS			PRODUCT CUSTOMER DRAWING	
	SERIES: 34735 MATERIAL NUMBER: 347350050 CUSTOMER:		DOCUMENT NUMBER: 347350050 DOC TYPE: PSD DOC PART: 000 SHEET NUMBER: 2 OF 2		
	RELEASE STATUS: P1 RELEASE DATE: 2020/05/23 03:21:07				

TABLE OF CONTENTS	
SHEET NO.	SHEET DESCRIPTION
1	INTERFACE NOTES AND BOM
2	INTERFACE KEY CONFIGURATIONS
3	INTERFACE DEFINITION
4	INTERFACE DATUM TARGETS

MATING INTERFACE CHART			
DESCRIPTION	COLOR	MODEL NUMBER	KEY
1X10, KEY A, BLACK	BLACK	349681801	A
1X10, KEY B, LIGHT GRAY	LIGHT GRAY	349681802	B
1X10, KEY C, DARK GRAY	DARK GRAY	349681803	C
1X10, KEY D, STONE GRAY	STONE GRAY	349681804	D

NOTES: VALID UNLESS OTHERWISE SPECIFIED

1. GENERAL:

REFER TO "SAE/USCAR 12 CONNECTOR GUIDELINES" AND "SAE/USCAR 2 PERFORMANCE SPECIFICATION FOR AUTOMOTIVE ELECTRICAL CONNECTOR SYSTEMS" FOR ADDITIONAL REQUIREMENTS.

2. DESIGN - MATERIALS:

- a. HOUSING: SPS/NYLON 20% GLASS FILLED OR EQUIVALENT
FLAMMABILITY REQUIREMENT: PER ISO3795 OR GM3191
 - 1. BURN RATE 100mm/MIN MAXIMUM
 - 2. MATERIAL MUST BE SELF EXTINGUISHING
- b. BLADE TERMINAL: SEE MOLEX SALES DRAWING 347350050. FOR MATERIAL, DIMENSIONAL, PLATING AND COATING REQUIREMENTS AND ANY BLADE TERMINAL DESIGN INFORMATION NOT SHOWN ON REFERENCED OR THIS DRAWING SEE EWCAP DWG NO. EWCAP-001.
 - 1. TIN PLATING: 2.5-4.0 MICROMETERS MATTE TIN OVER 1.25-2.25 MICROMETERS DUCTILE SULFAMATE NICKEL
 - 2. SILVER PLATING: 1.9-3.3 MICROMETERS SILVER OVER 1.0-1.8 MICROMETERS DUCTILE SULFAMATE NICKEL.
ANTI-TARNISH: SYNTHETIC HYDROCARBON CONTACT SURFACE FINISH OR EQUIVALENT APPLIED WITHOUT VOID TO CONTACT AREA

c. STANDARD COLORS FOR KEYING (SEE CHART). DEVATION REQUIRES APPROVAL OF AUTHORIZED PERSON.

3. DESIGN - GEOMETRY:

- a. THE 3-D CAD DATA IS BASIC (WITHOUT TOLERANCE) AND THE MASTER FOR THIS PART WITH THE EXCEPTION OF UNDERLINED DIMENSIONS. DIMENSIONAL INFORMATION NOT SHOWN IN THIS DRAWING IS DEFINED BY THE DATA FILE AT ITS LATEST REVISION.
- b. PRODUCT DESIGN MODEL NUMBER(S): SEE MATING INTERFACE CHART
- c. GEOMETRIC DIMENSIONS AND TOLERANCES PER ASME Y14.5M - 2009
- d. GENERAL TOLERANCES: SEE TITLE BLOCK
- e. EDGES AND UNDIMENSIONED DETAILS PER ISO13715
- f. CORNERS SHOWN AS SHARP TO BE R 0.2 MAX.
- g. LETTERING SHALL BE 0.15 MAX RAISED IN 0.25 MAX RECESS PAD.
THIS INCLUDES RECYCLING CODE, CAVITY ID, VENDOR IDENTIFICATION, AND CUSTOMER MATERIAL NUMBER.
(FOR SMALL PARTS: LETTERING SHALL BE 0.10 MAX RAISED IN 0.15 MAX RECESS PAD)

4. DESIGN - MANUFACTURING:

- a. ALLOWABLE FLASH MAX 0.20 HIGH BY MAX 0.13 THICK.
- b. ALLOWABLE SPLIT/PARTING LINE MISMATCH 0.2 MAX.
- c. EJECTOR PIN MARKS TO BE FLUSH TO 0.25 MAX DEPRESSED. LOCATION MUST BE APPROVED BY PRODUCT ENGINEERING. EJECTOR PIN MARKS NOT PERMISSIBLE ON OR NEAR DATUM TARGET AREA.
- d. ALLOWABLE GATE VESTIGE FLUSH TO 0.25 MAX RECESS. LOCATION MUST BE APPROVED BY PRODUCT ENGINEERING.
- e. NO EXTERNAL MOLD RELEASE AGENT ALLOWED DURING MANUFACTURING.
- f. NO PARTING LINES, MISMATCHES OR EJECTOR MARKS PERMISSIBLE WITHIN THE INDICATED SURFACE. TOOLING FOR INDICATED SURFACE MUST BE PROCESSED TO A SURFACE FINISH OF NTMA #70 (400 PAPER)
- g. BLADE TERMINAL ENVIRONMENTAL BARRIER (USED WITH SILVER PLATED TERMINALS) SHALL NOT BE PRESENT ON ANY SURFACE OTHER THAN THE BLADE TERMINALS
- h. NO PARTING LINES, FLASH, MISMATCHES OR EJECTOR MARKS PERMISSIBLE ON THE INDICATED NOSE SURFACE OR TRANSITION TO INTERNAL SHROUD SURFACE.

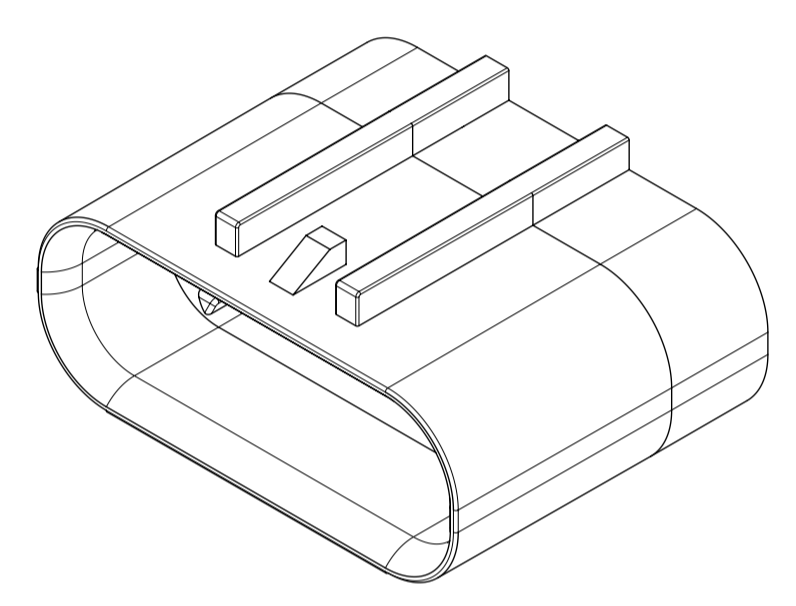

1X10

NOTICE: PRODUCT IN DEVELOPMENT & SUBJECT TO CHANGE WITHOUT NOTIFICATION

D	CHANGED RIB REMOVAL FOR KEYING: SEE VIEWS SHEET 2. ADDED SEE NOTE 2 TO PIN DETAIL SHEET 3. REVISED NOTE 4f.
C1	REVISED NOTES AND DIMENSIONS
C	RELEASE
REV	REV DESCRIPTION

INSPECTION NUMBER LOG	
LAST NUMBER:	ICD-31
ADDED:	ICD-21A, ICD-21B
REMOVED:	ICD-20,23,24,25, 29, 31

QUALITY SYMBOLS FA = 0 FE = 0 FE = 0 ▼ = 0 C = 0 ☒ = 0 ■ = 0 ∇ = 0	THIS DRAWING CONTAINS INFORMATION THAT IS PROPRIETARY TO MOLEX ELECTRONIC TECHNOLOGIES, LLC AND SHOULD NOT BE USED WITHOUT WRITTEN PERMISSION			
	EC NO: 121633	DRWN: JURUTTER	CHKD: JCONDON	REV APPR: JCONDON
	2017/04/03	2017/09/15	2017/09/15	2017/09/15
	GENERAL TOLERANCES (UNLESS SPECIFIED)		DIMENSION UNITS	SCALE
ANGULAR TOL ± 3.0 °		mm	1:1	
4 PLACES ±	MNS02	DRWN BY	DATE	
3 PLACES ±		CHK'D BY	DATE	
2 PLACES ± 0.1		APPR BY	DATE	
1 PLACE ± 0.2	KDEKOSKI		2016/05/04	
0 PLACES ±		DRAWING SIZE	THIRD ANGLE PROJECTION	
DRAFT WHERE APPLICABLE MUST REMAIN WITHIN DIMENSIONS		A1		
SERIES		MATERIAL NUMBER	CUSTOMER	
34968		SEE CHART		
DOCUMENT NUMBER		DOC TYPE	DOC PART SHEET NUMBER	
349681800		PSD	000 1 OF 4	

SHEET DESCRIPTION
KEY CONFIGURATIONS

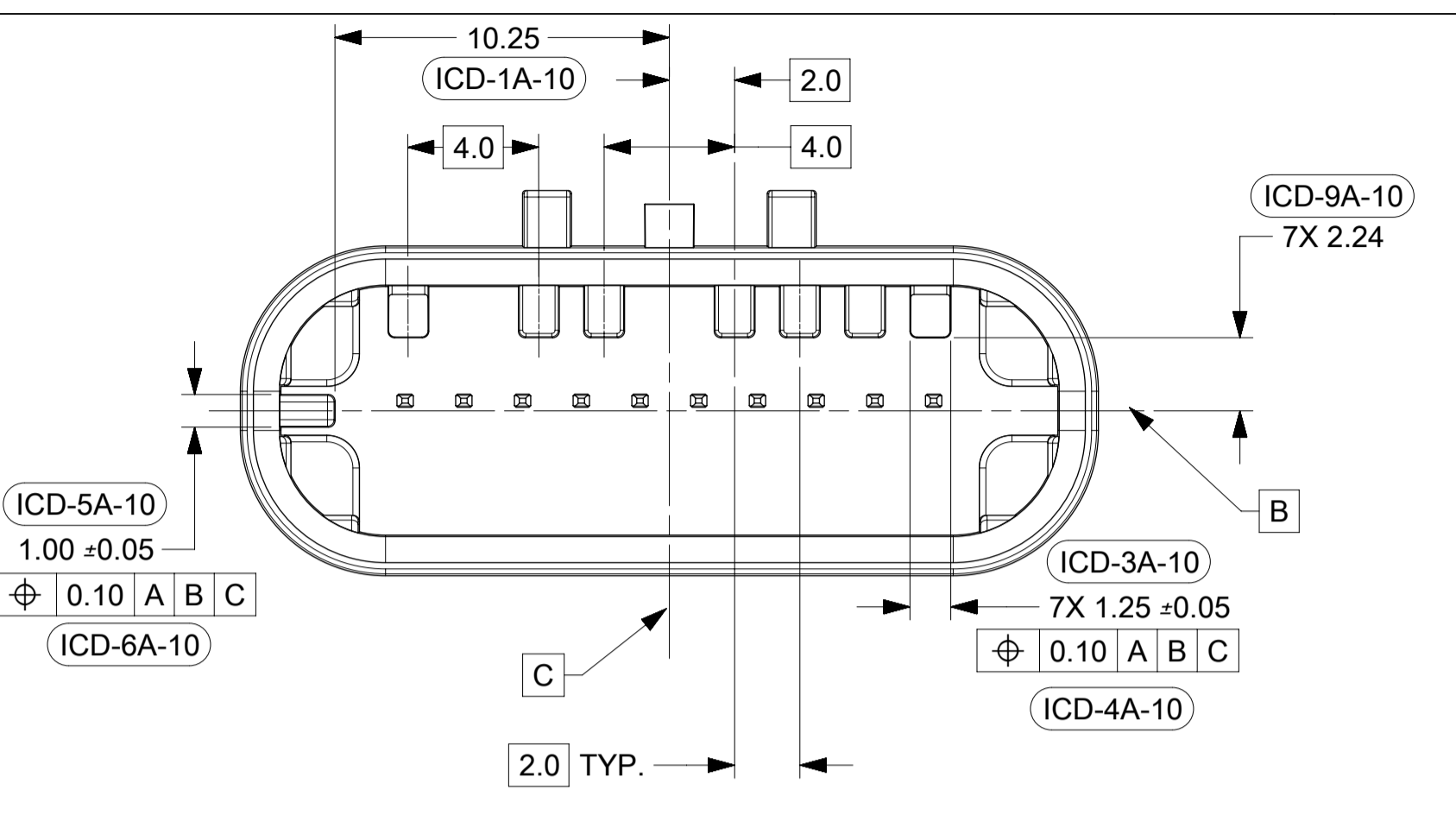

KEY OPTION A

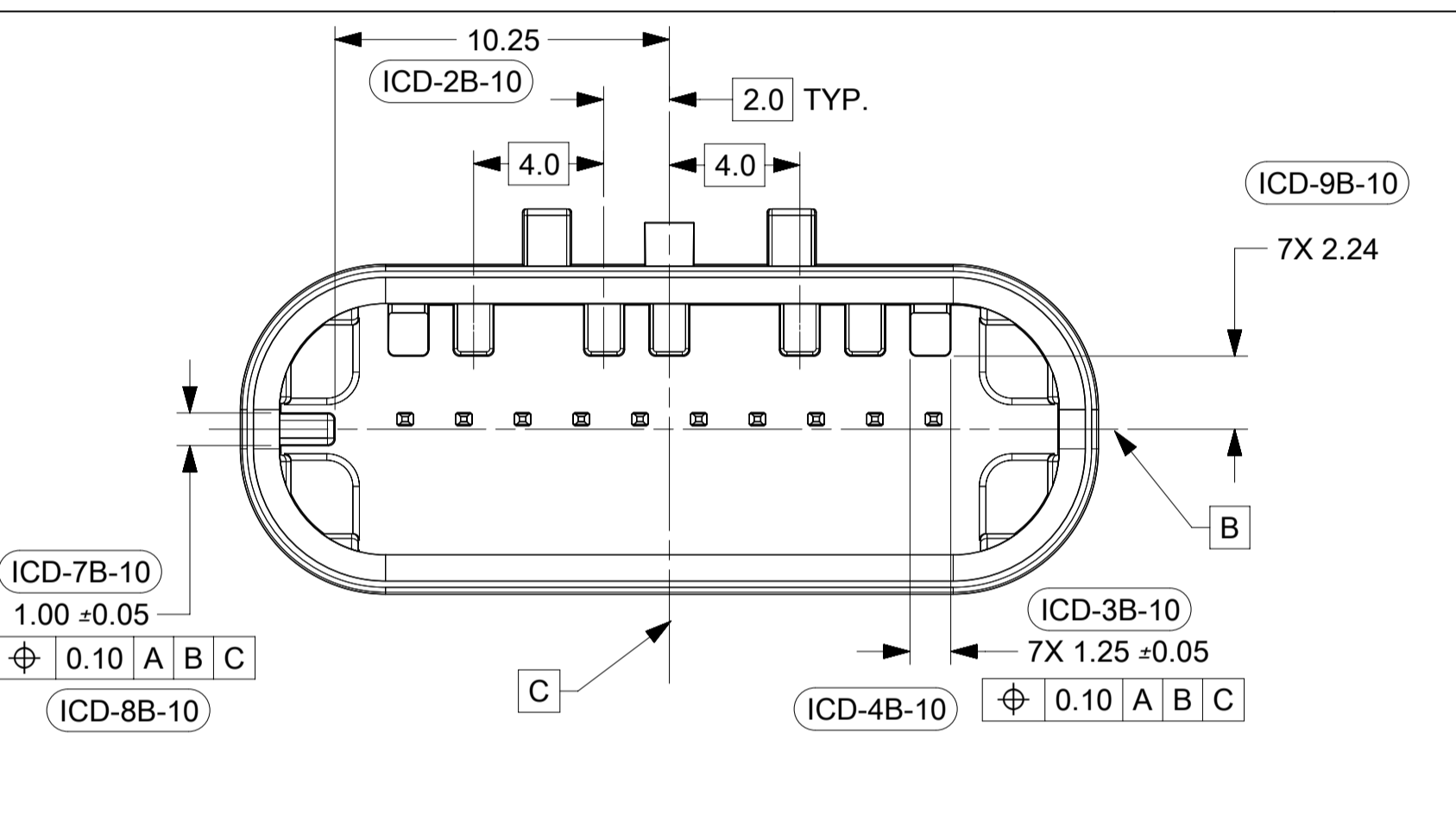

KEY OPTION B

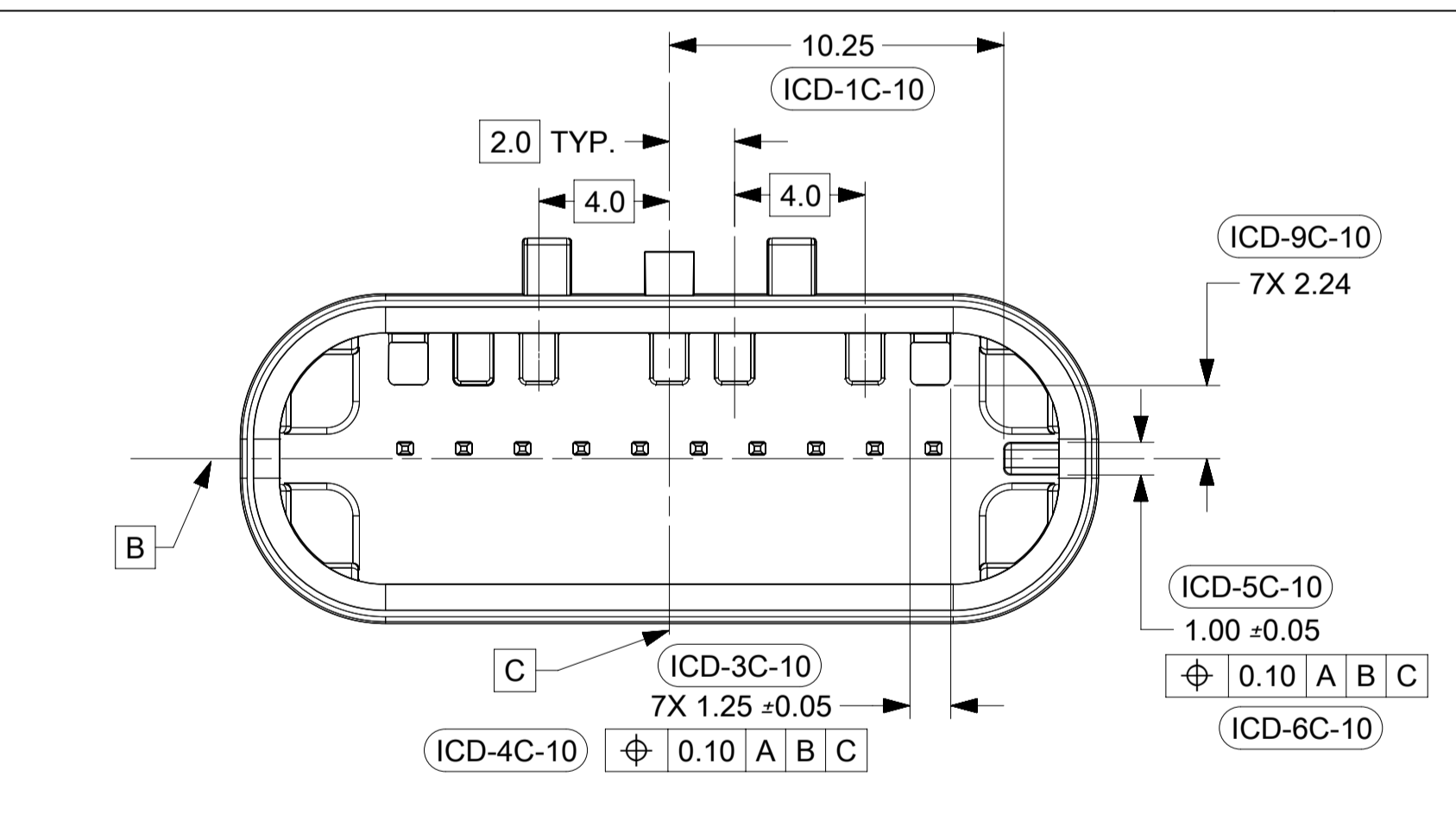

KEY OPTION C

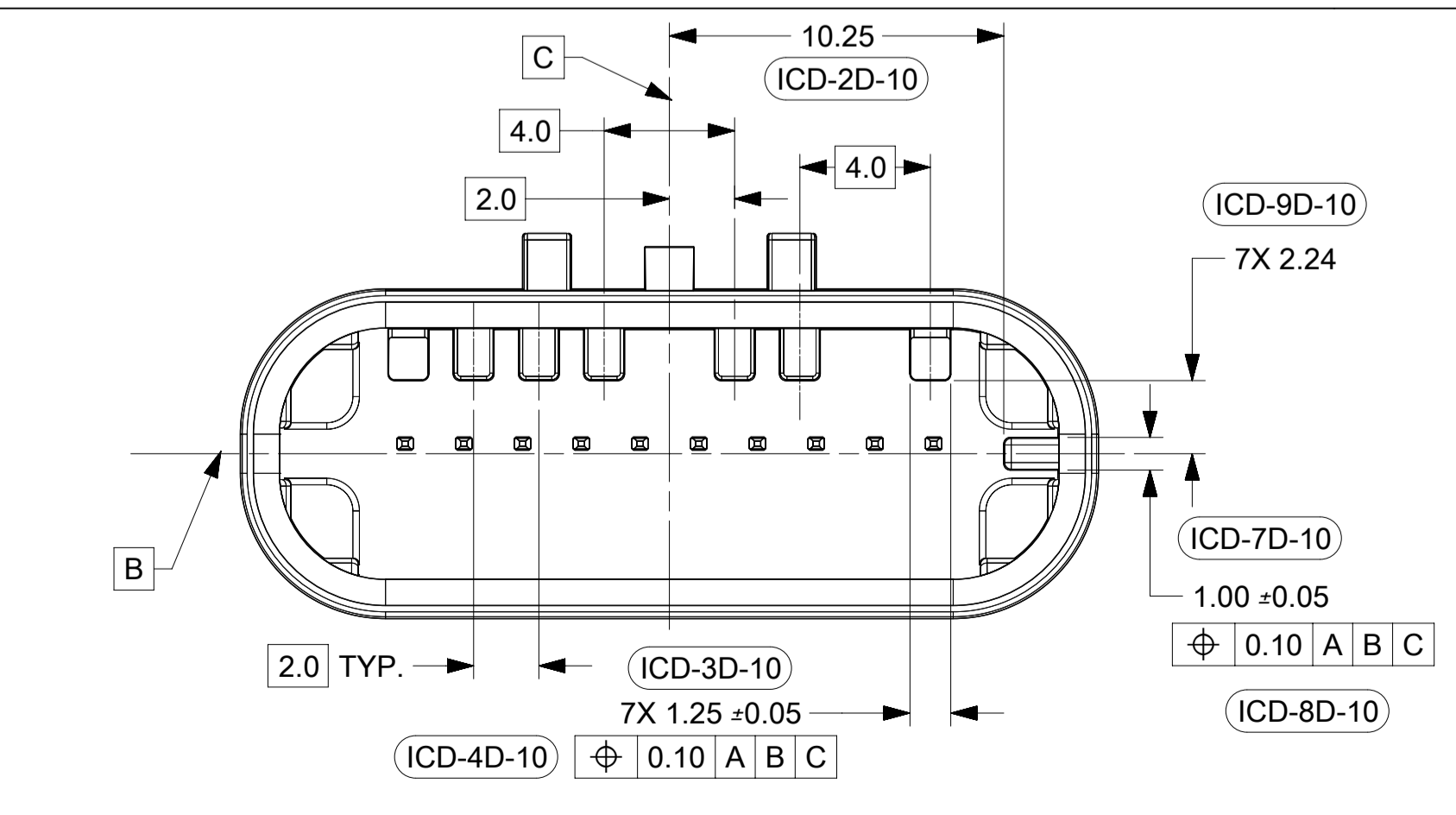

KEY OPTION D

THIS DRAWING CONTAINS INFORMATION THAT IS PROPRIETARY TO MOLEX ELECTRONIC TECHNOLOGIES, LLC AND SHOULD NOT BE USED WITHOUT WRITTEN PERMISSION											
QUALITY SYMBOLS	2017/04/03	2017/09/15	GENERAL TOLERANCES (UNLESS SPECIFIED)		DIMENSION UNITS	SCALE					
			ANGULAR TOL ± 3.0 °		mm	1:1					
▽ = 0	EC NO: 121633 DRWN: JURUTTER CHKD: REV / APPR: JCONDON	MNS02	4 PLACES ±		DRWN BY	DATE	mini50 SEALED 1X10 INTERFACE				
▽ = 0			3 PLACES ±		CHK'D BY	DATE					
▽ = 0			2 PLACES ± 0.1		APPR BY	DATE	PRODUCT CUSTOMER DRAWING				
▽ = 0			1 PLACE ± 0.2		KDEKOSKI	2016/05/04					
▽ = 0			0 PLACES ±		DRAWING SIZE	THIRD ANGLE PROJECTION	SERIES	MATERIAL NUMBER	34968 SEE CHART		
▽ = 0			DRAFT WHERE APPLICABLE MUST REMAIN WITHIN DIMENSIONS		A1		34968	349681800			
▽ = 0	RELEASE STATUS		P1	RELEASE DATE	15.09.2017	16:36:07	DOC TYPE	DOC PART	SHEET NUMBER		
							PSD	000	2 OF 4		

SHEET DESCRIPTION
CONNECTOR INTERFACE DEFINITION

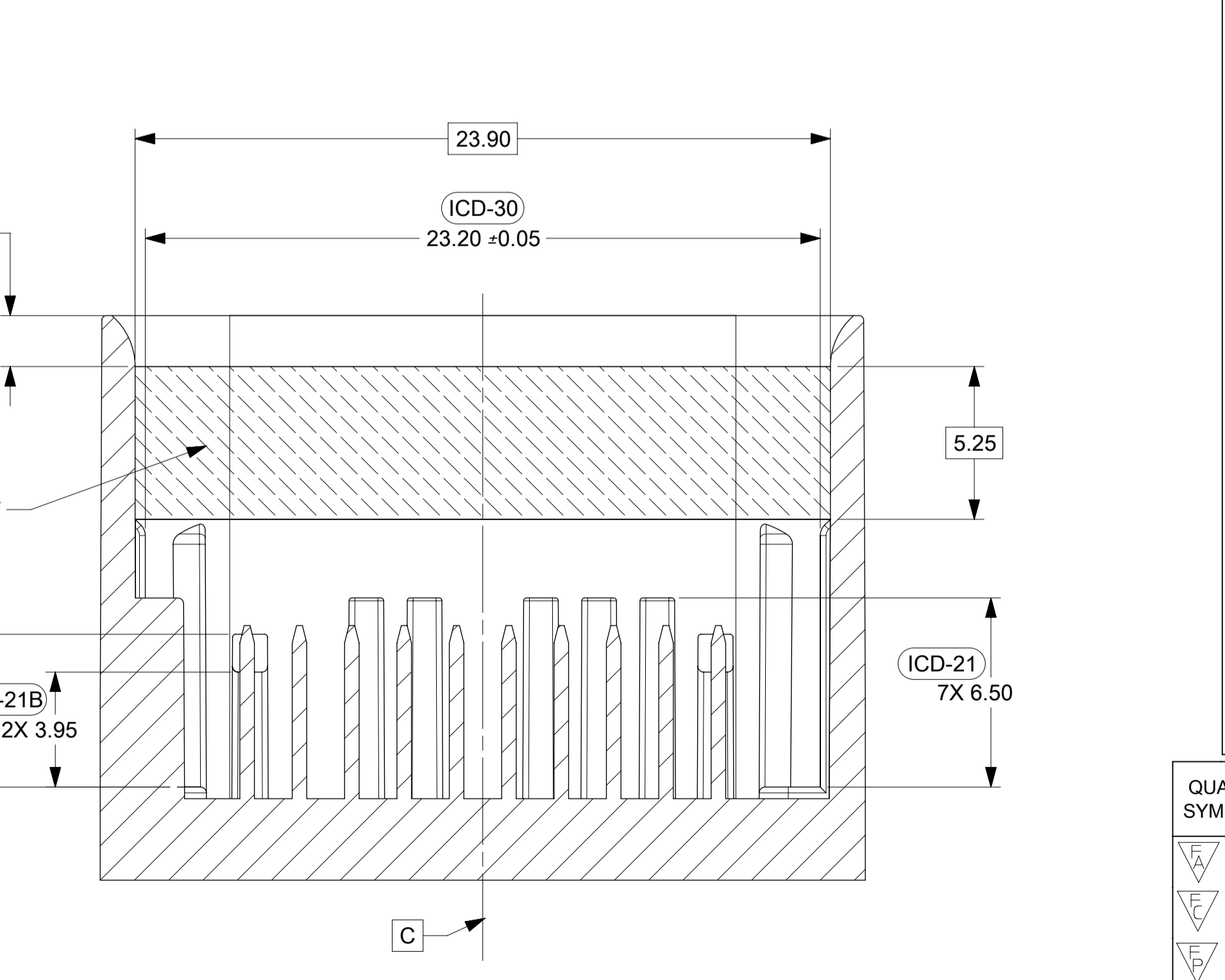
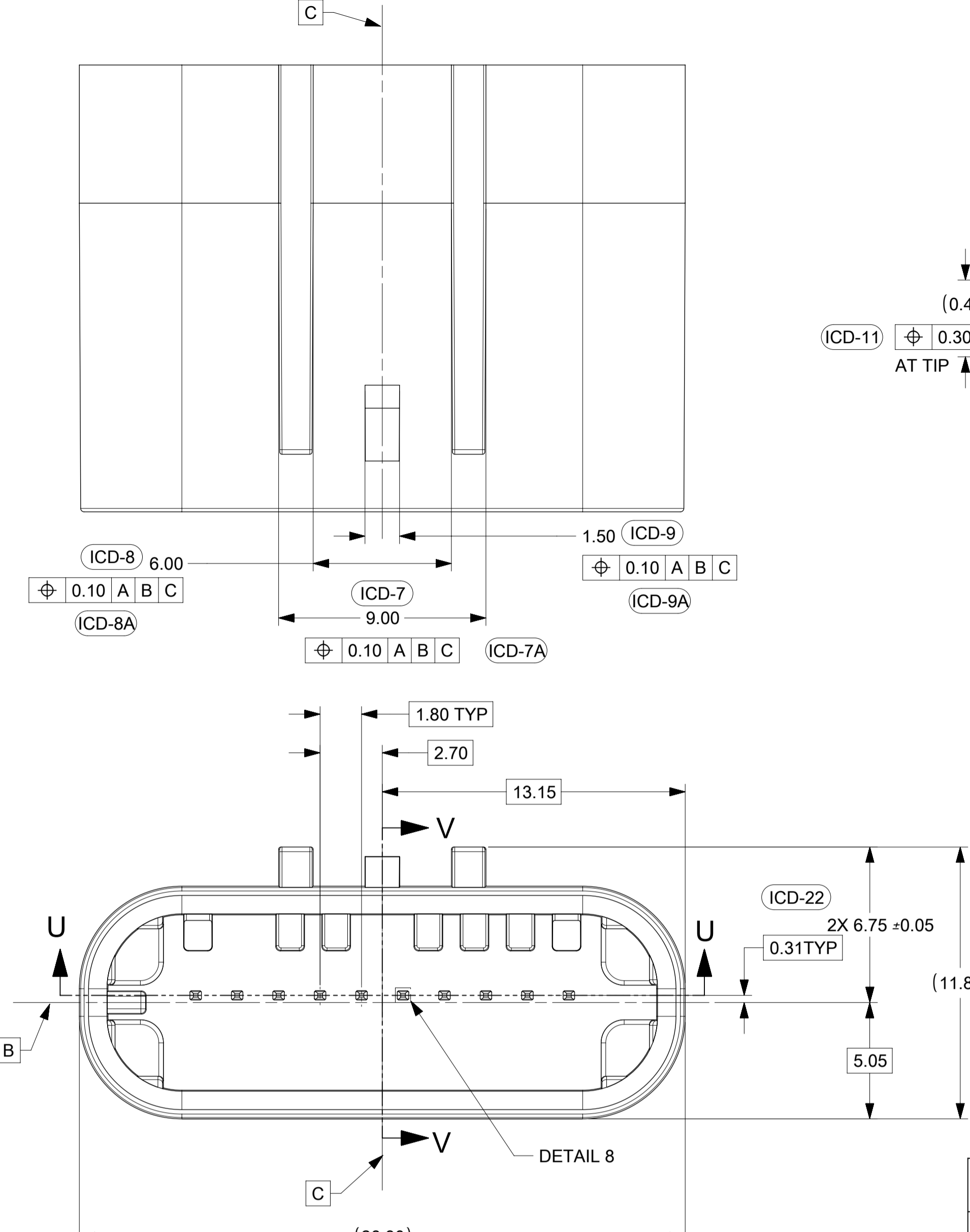
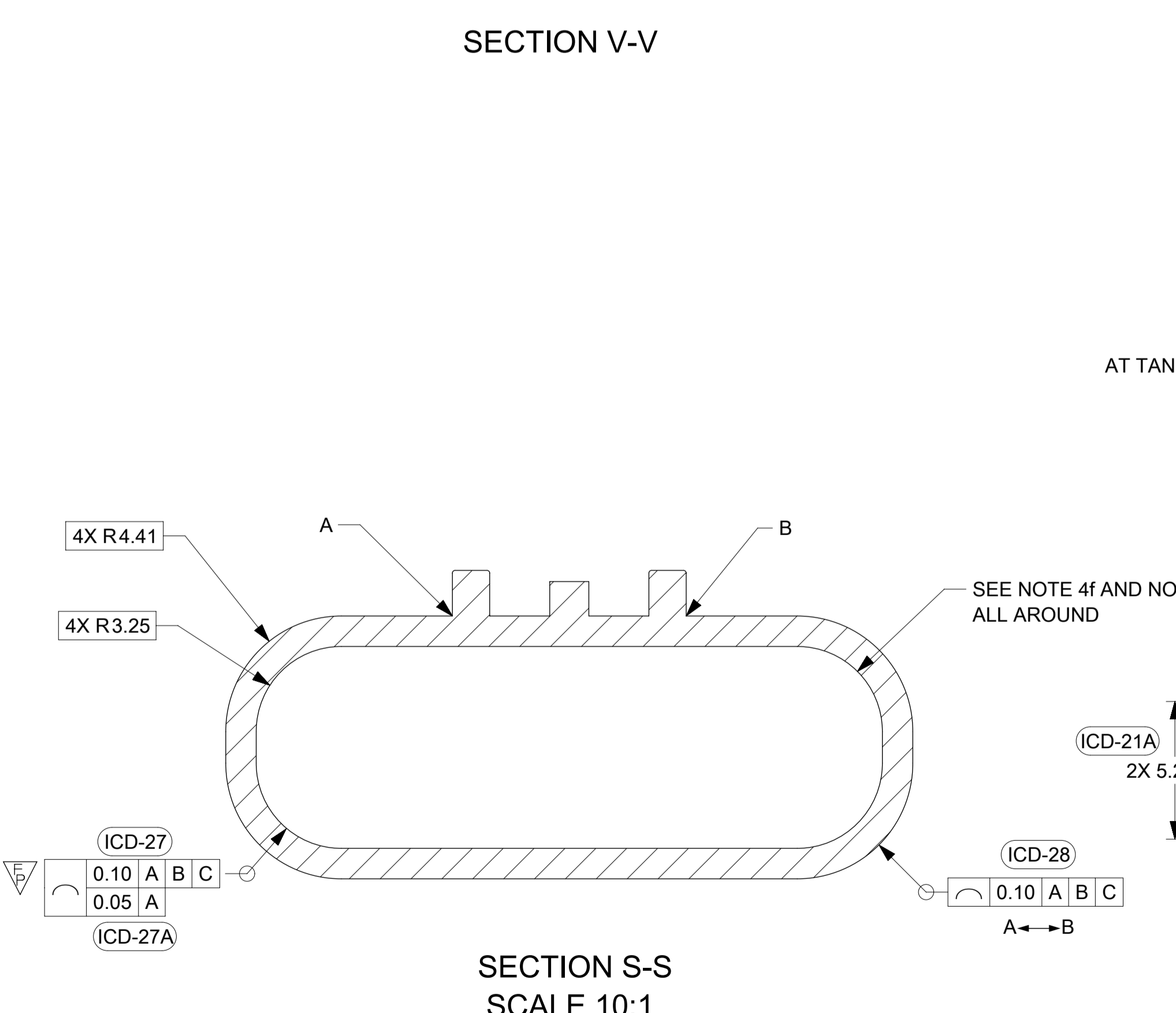
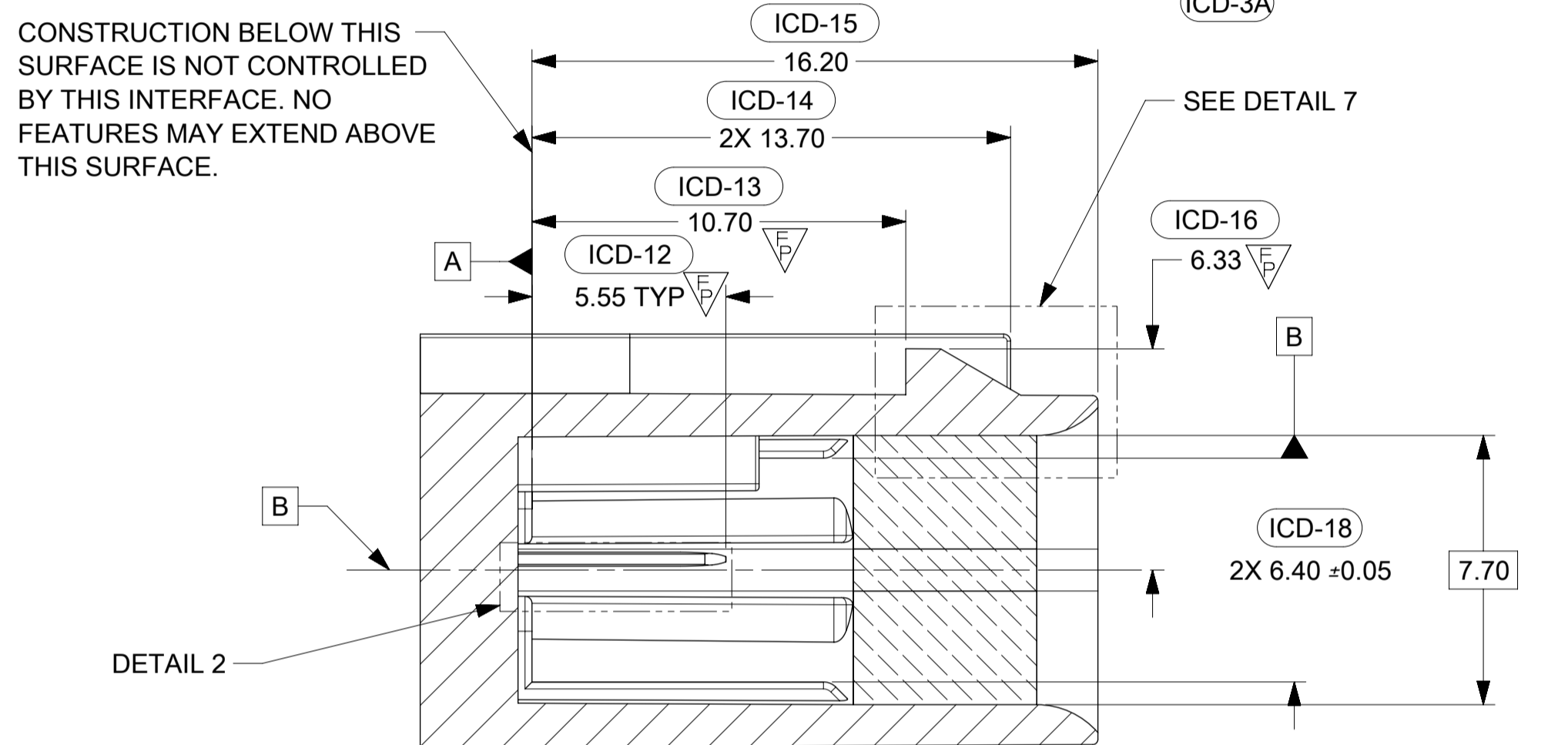
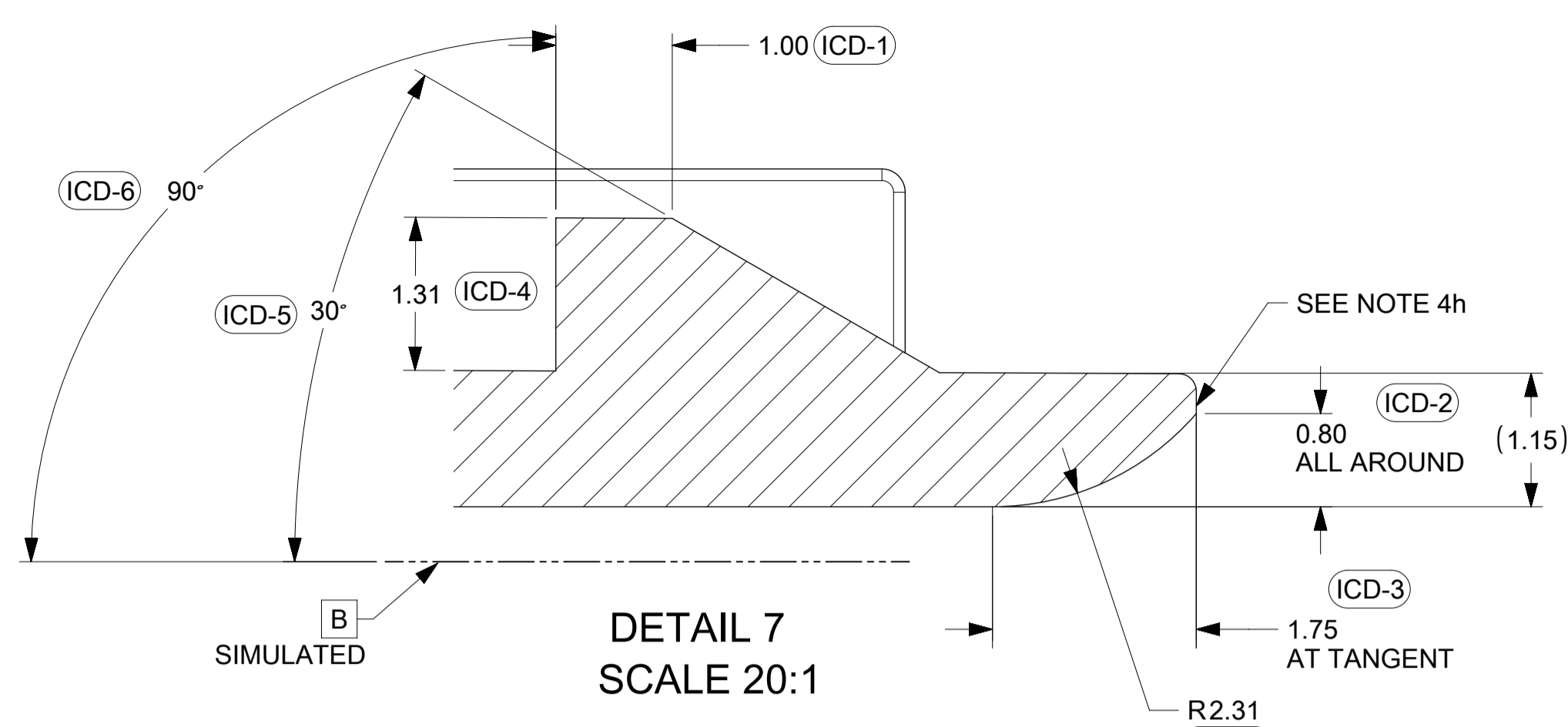

SEE NOTE 2
REFER TO MOLEX SALES DWG 347350050
AND EWCAP DWG. NO. EWCAP-001 REV. P 050-T001
0.50 TERMINAL BLADE CONFIGURATION

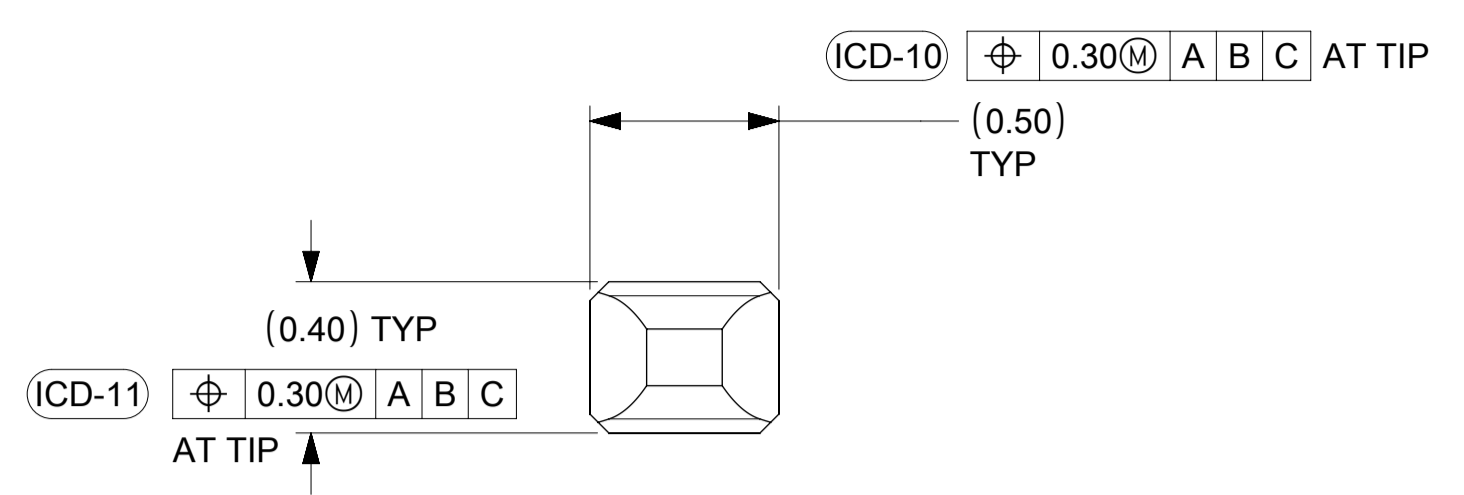

DETAIL 8
SCALE 50:1

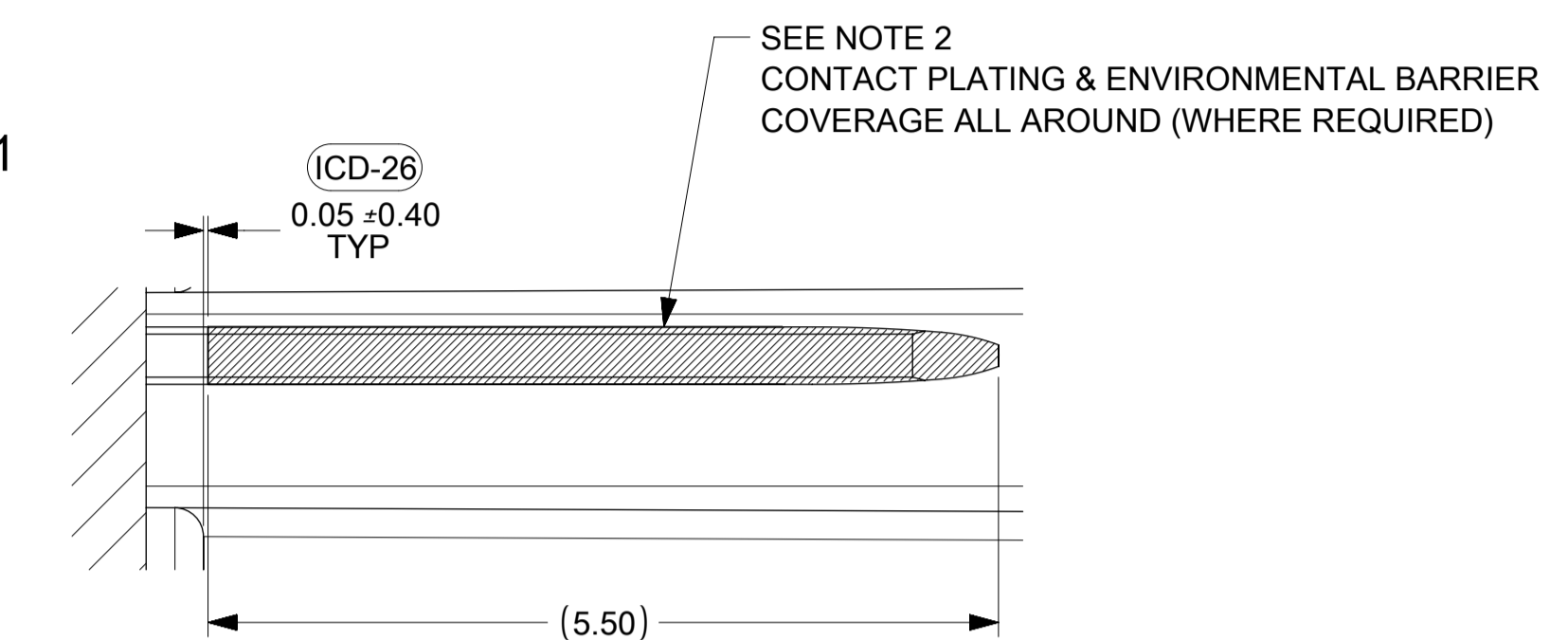

DETAIL 2
SCALE 20:1

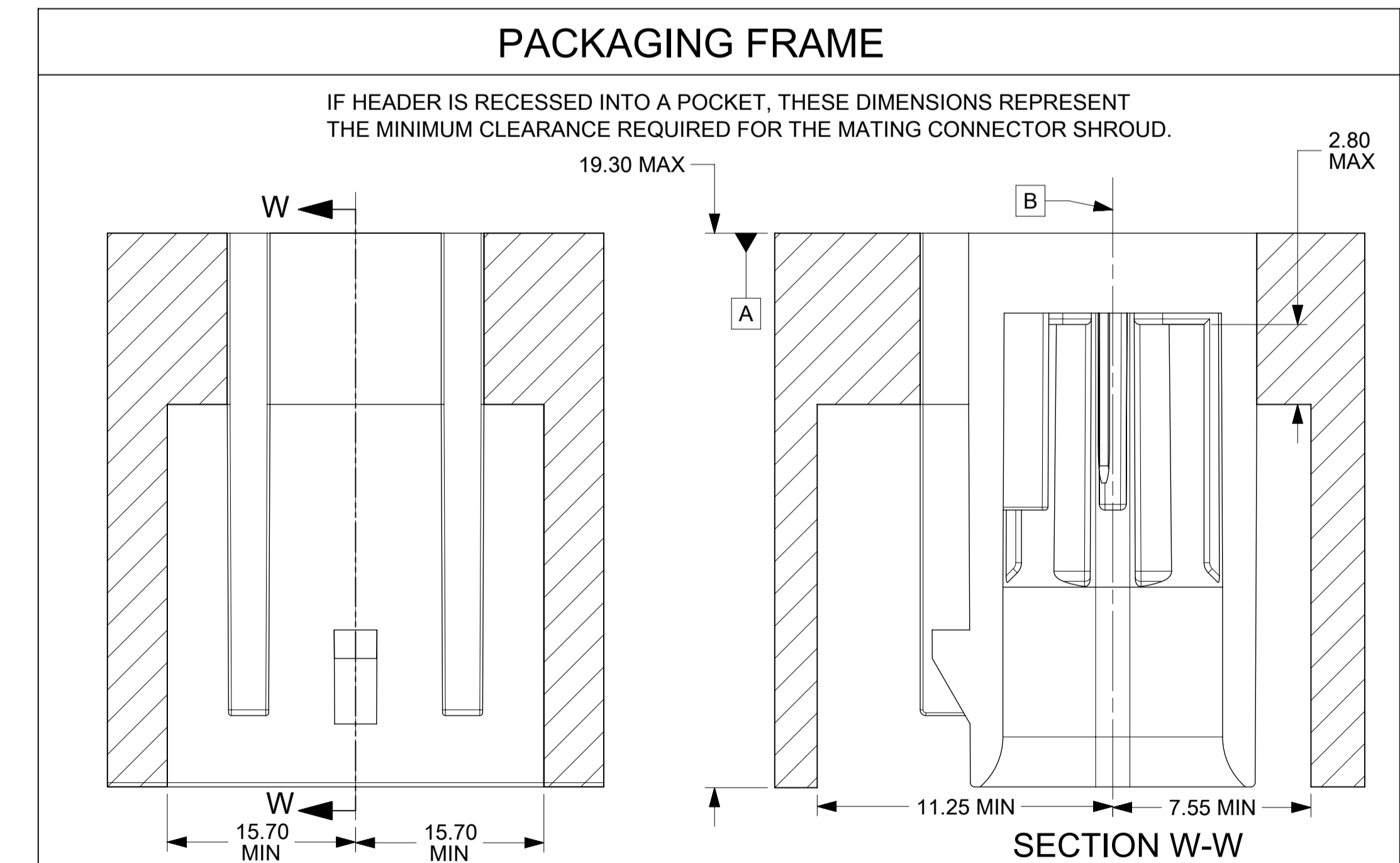
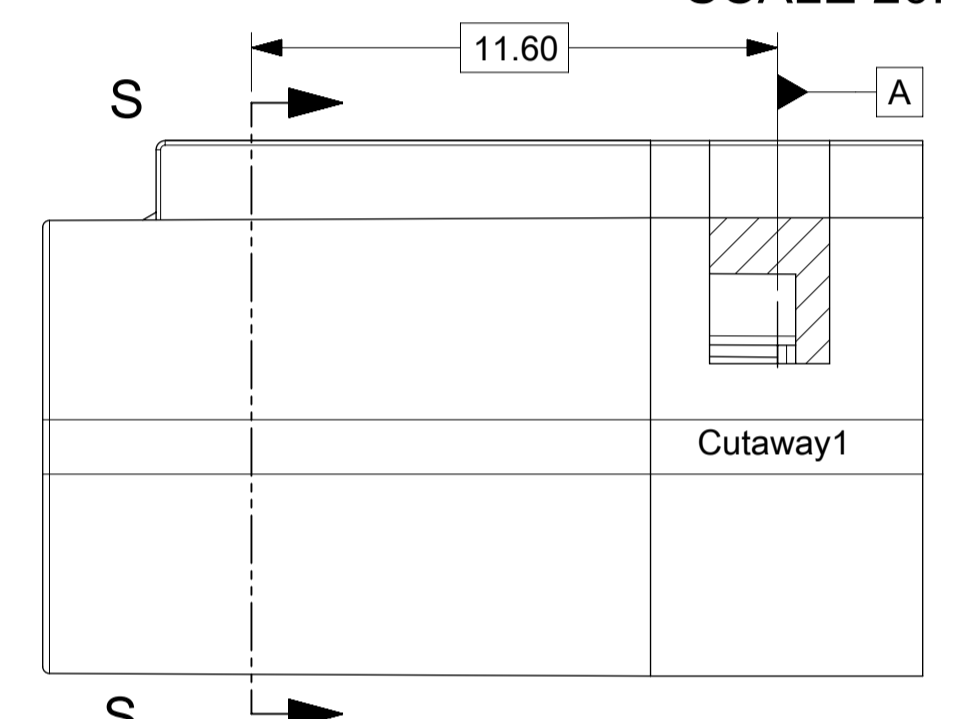

PACKAGING FRAME

<p>THIS DRAWING CONTAINS INFORMATION THAT IS PROPRIETARY TO MOLEX ELECTRONIC TECHNOLOGIES, LLC AND SHOULD NOT BE USED WITHOUT WRITTEN PERMISSION</p>		<p>QUALITY SYMBOLS</p> <ul style="list-style-type: none"> ▽ = 0 ▽ = 0 ▽ = 0 ▽ = 0 ▽ = 0 ▽ = 0 ▽ = 0 ▽ = 0 ▽ = 0 ▽ = 0 		<p>GENERAL TOLERANCES (UNLESS SPECIFIED)</p> <p>ANGULAR TOL ± 3.0 °</p> <p>4 PLACES ±</p> <p>3 PLACES ±</p> <p>2 PLACES ± 0.1</p> <p>1 PLACE ± 0.2</p> <p>0 PLACES ±</p> <p>DRAFT WHERE APPLICABLE MUST REMAIN WITHIN DIMENSIONS</p>		<p>DIMENSION UNITS</p> <p>mm</p> <p>SCALE</p> <p>1:1</p>		<p>DRWN BY</p> <p>DATE</p> <p>2017/04/03</p> <p>2017/09/15</p> <p>MNS02</p> <p>2016/04/21</p>		<p>CHK'D BY</p> <p>DATE</p> <p>APPR BY</p> <p>DATE</p> <p>JCONDON</p> <p>2016/05/04</p>		<p>PRODUCT CUSTOMER DRAWING</p> <p>MINI50 SEALED 1X10 INTERFACE</p>		<p>SERIES</p> <p>MATERIAL NUMBER</p> <p>CUSTOMER</p> <p>34968</p> <p>SEE CHART</p>		<p>DOCUMENT NUMBER</p> <p>DOC TYPE</p> <p>DOC PART</p> <p>SHEET NUMBER</p> <p>349681800</p> <p>PSD</p> <p>000</p> <p>3 OF 4</p>	
--	--	---	--	--	--	--	--	---	--	---	--	---	--	--	--	---	--

SHEET DESCRIPTION
DATUM TARGETS

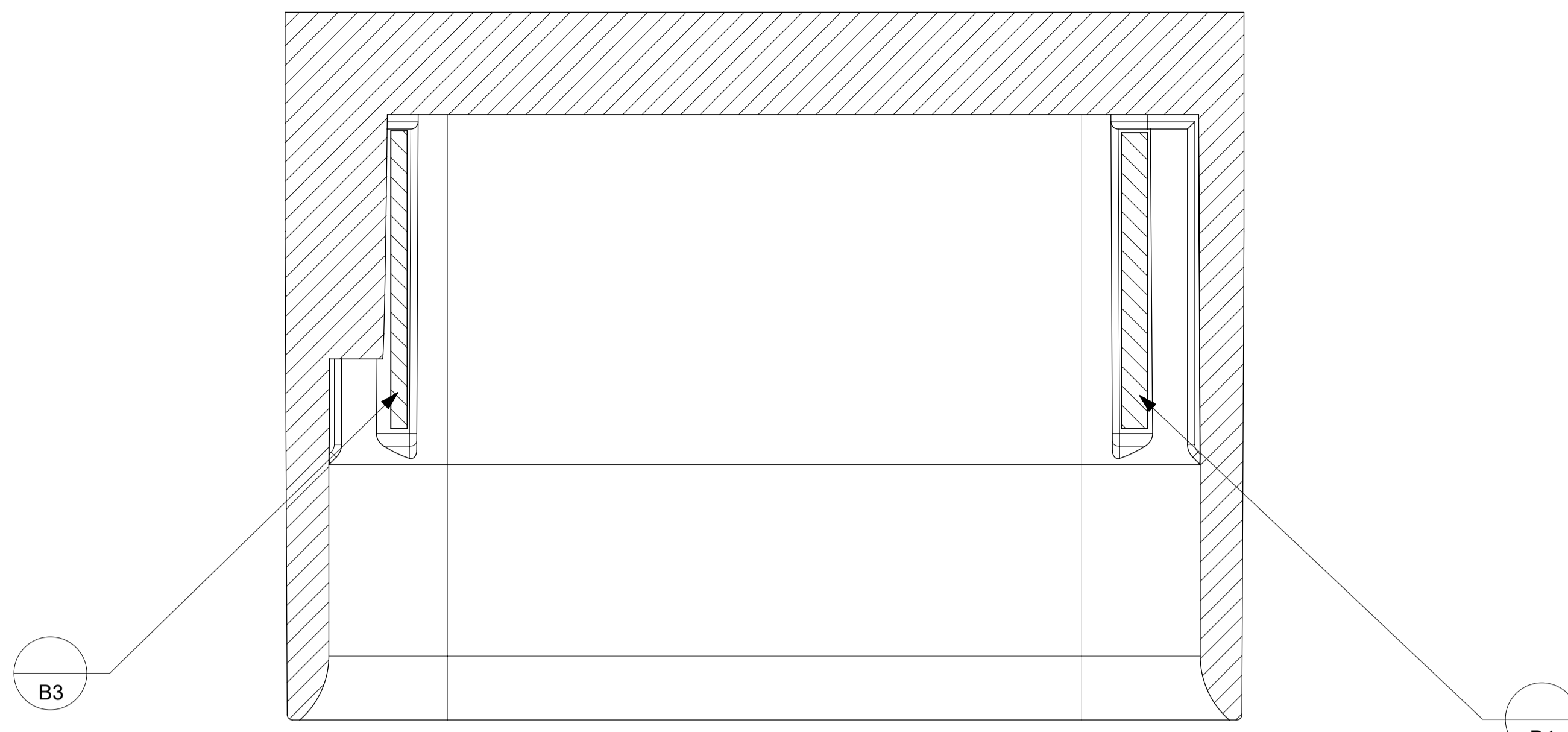

SECTION P-P

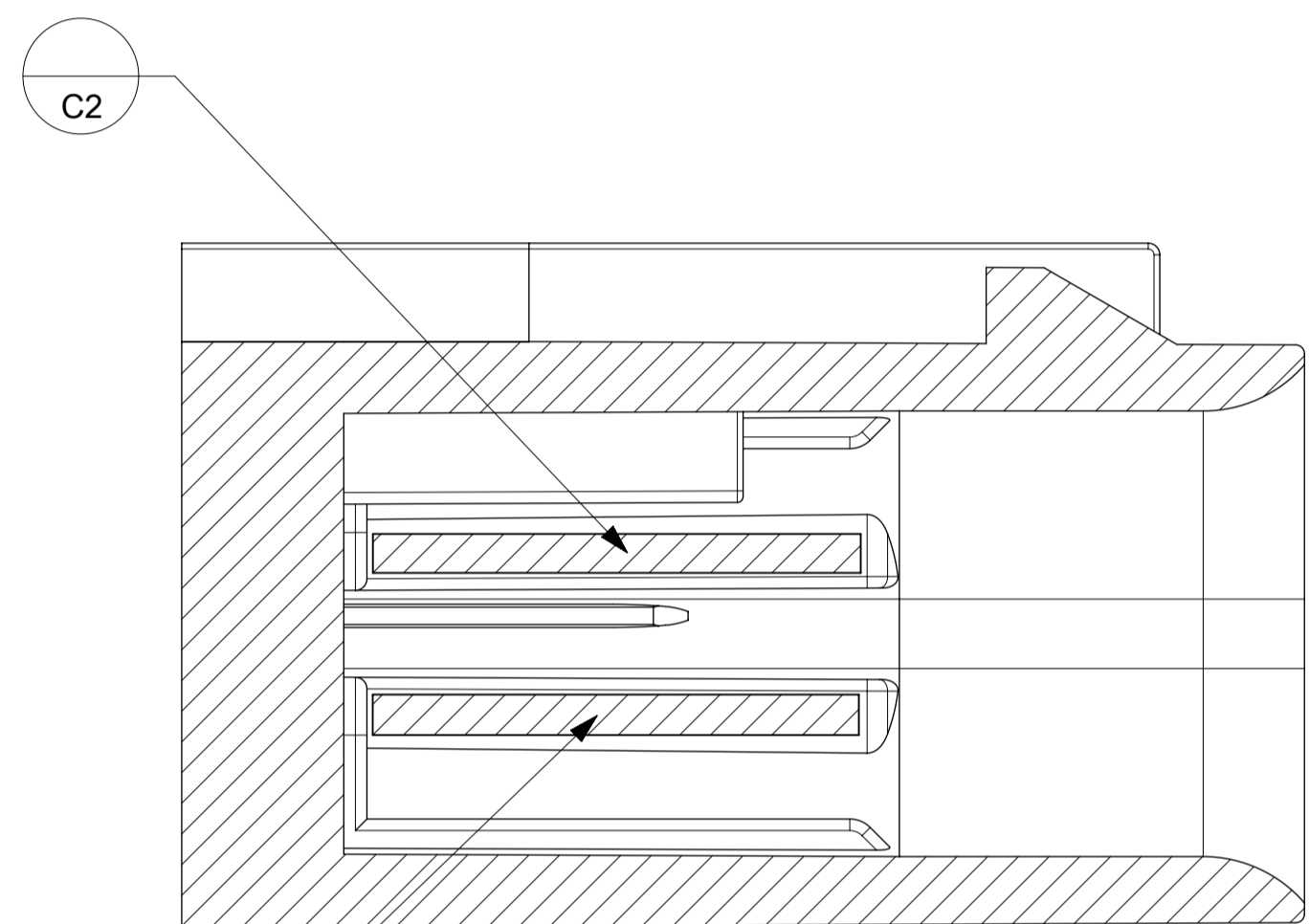

SECTION N-N

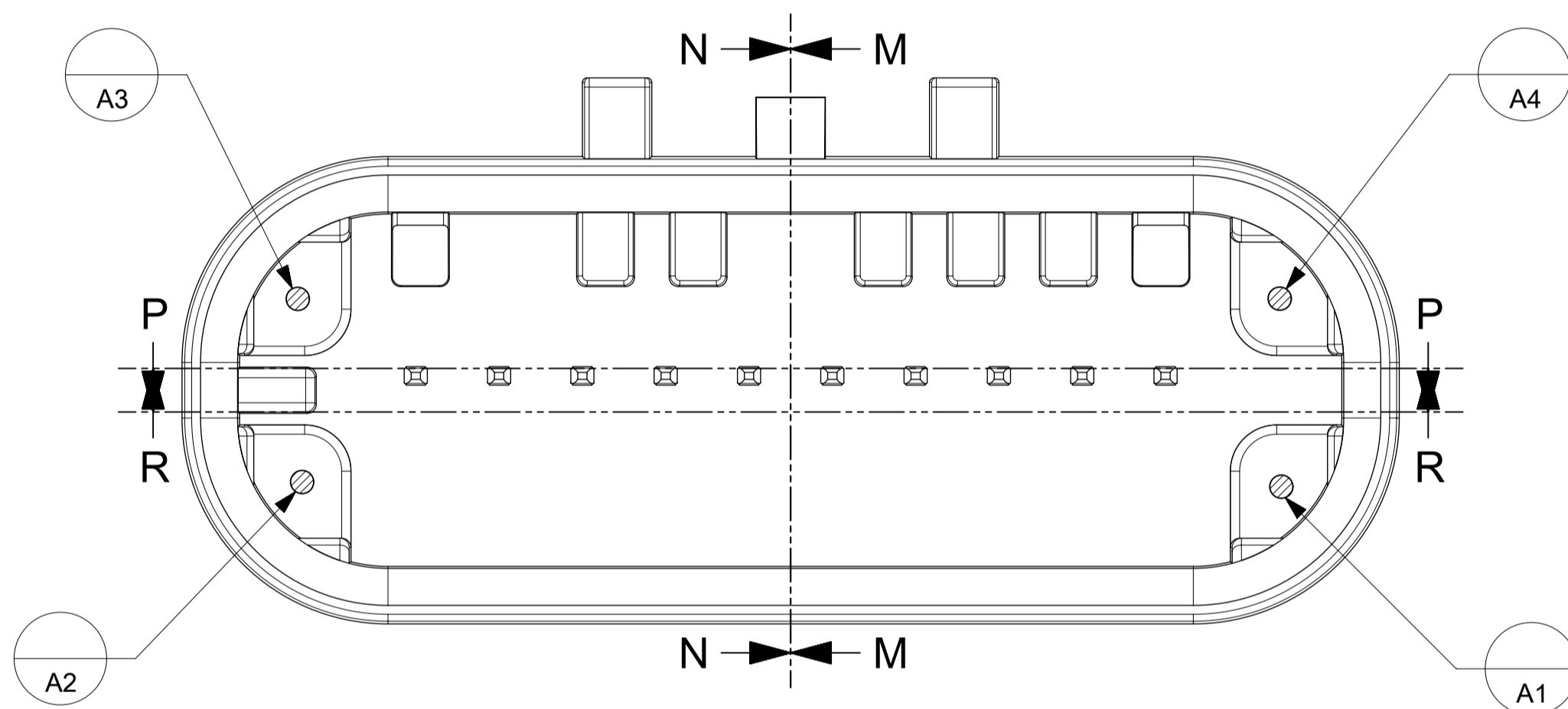

SECTION R-R

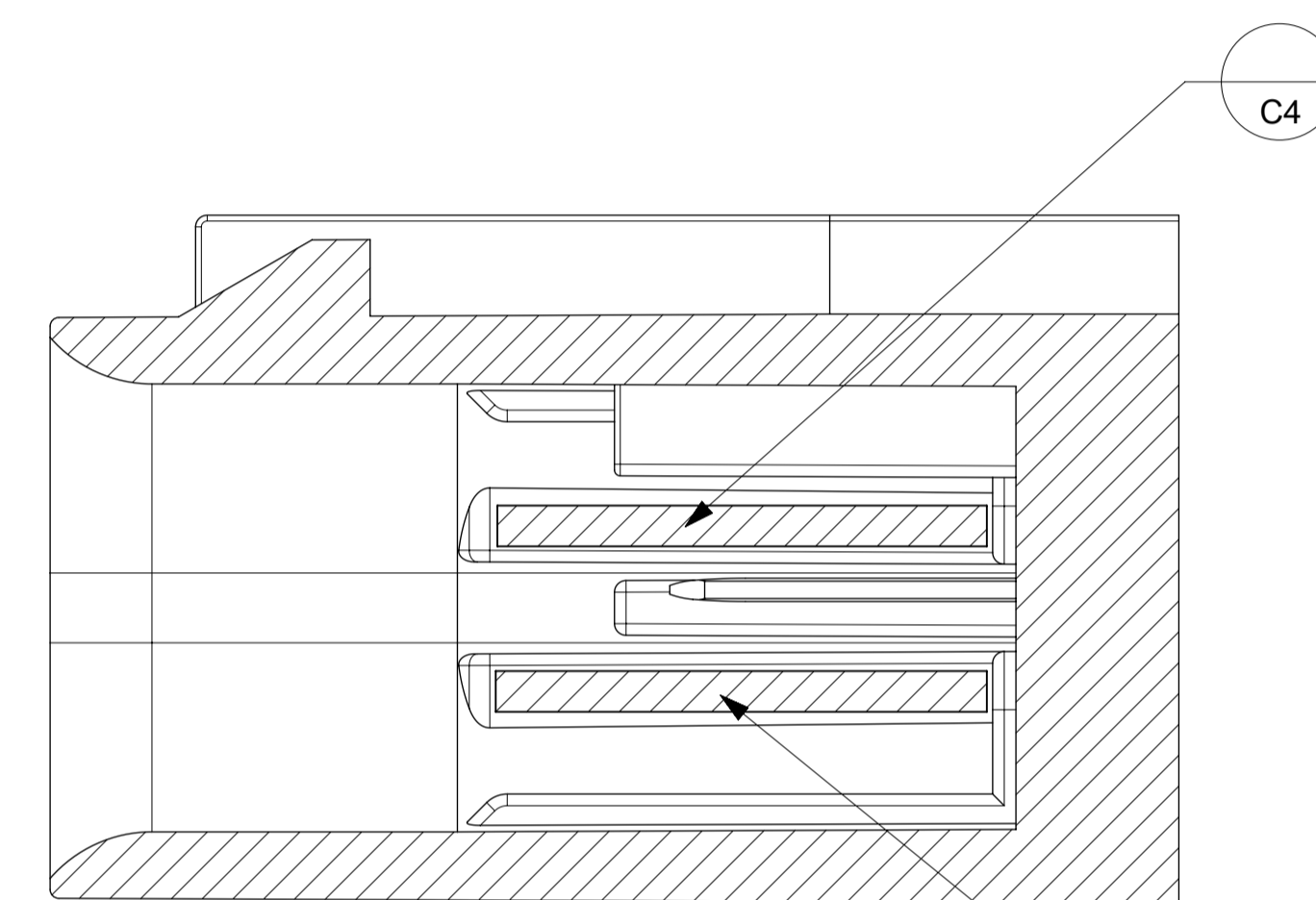

SECTION M-M

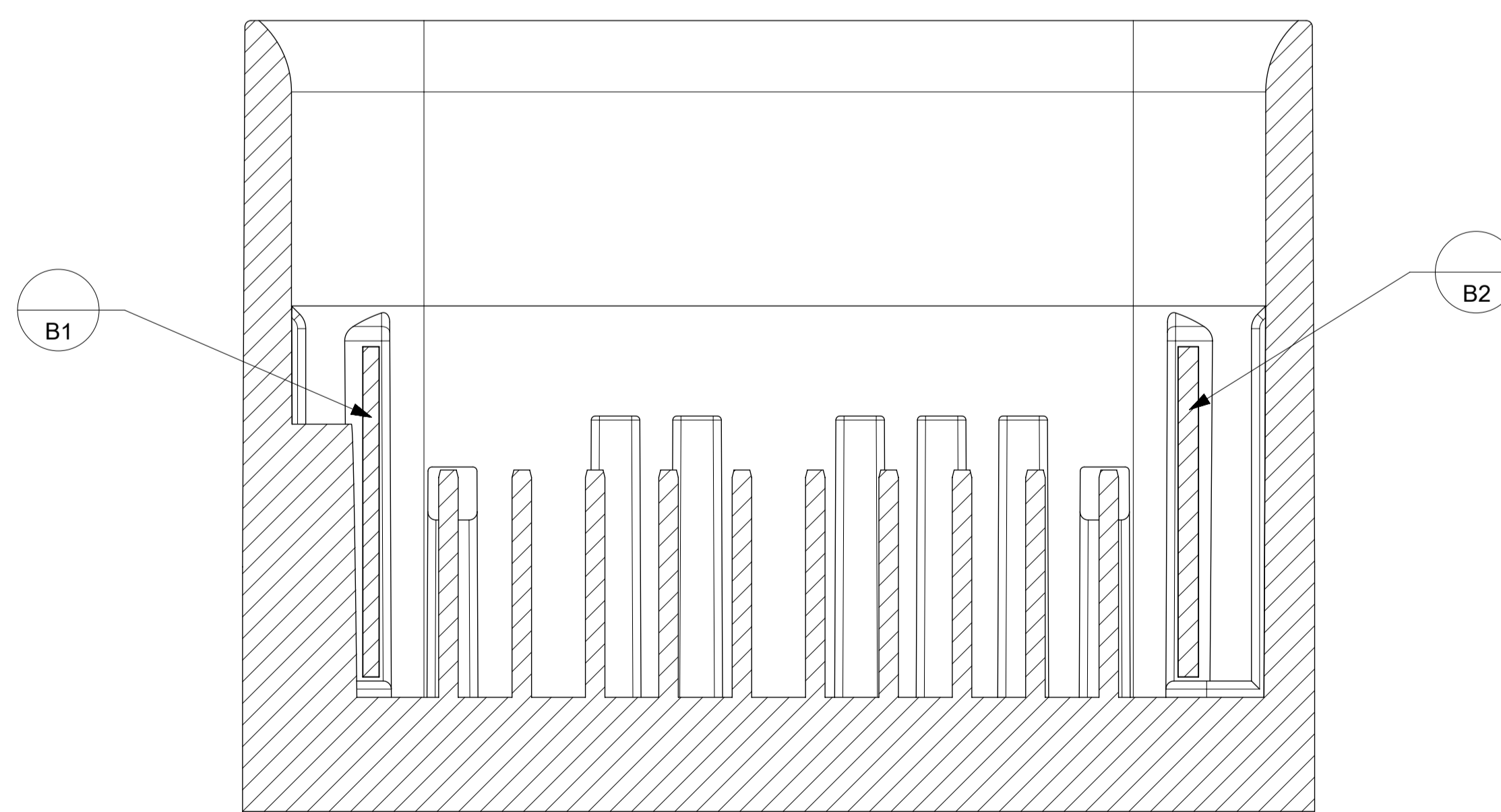

SECTION R-R

THIS DRAWING CONTAINS INFORMATION THAT IS PROPRIETARY TO MOLEX ELECTRONIC TECHNOLOGIES, LLC AND SHOULD NOT BE USED WITHOUT WRITTEN PERMISSION													
QUALITY SYMBOLS 	EC NO: 121633 DRWN: JRUTTER CHK'D: APPR: JCONDON	2017/04/03		2017/09/15		GENERAL TOLERANCES (UNLESS SPECIFIED)		DIMENSION UNITS	SCALE				
		mm		8:1		ANGULAR TOL ± 3.0 °		DRWN BY	DATE				
		MNS02		2016/04/21		4 PLACES ±		CHK'D BY	DATE				
		3 PLACES ±		2 PLACES ± 0.1		APPR BY		DATE		SERIES		MATERIAL NUMBER	CUSTOMER
		2 PLACES ± 0.2		1 PLACE ±		KDEKOSKI		2016/05/04		34968		SEE CHART	
		0 PLACES ±		DRAFT WHERE APPLICABLE MUST REMAIN WITHIN DIMENSIONS		DRAWING SIZE		THIRD ANGLE PROJECTION		DOCUMENT NUMBER		DOC TYPE	DOC PART
A1		A1		A1		A1		349681800		PSD	000	4 OF 4	