

REVISIONS					
P	LTR	DESCRIPTION	DATE	DWN	APVD
C1		REVISED PER ECR-22-160893	14DEC2022	DB	BW

- MATING TAB THK TO BE 0.81 ± 0.025 [.032 ± .001]
- WIRE SIZE IS [#18-#14] AWG.
- INSULATION RANGE IS 2.79-4.57 [.110-.180] DIA.
 2.79-3.56 [.110-.140] DIA - CRIMP WIDTH 4.57 [.180], F TYPE
 3.56-4.57 [.140-.180] DIA - CRIMP WIDTH 4.57 [.180], O TYPE

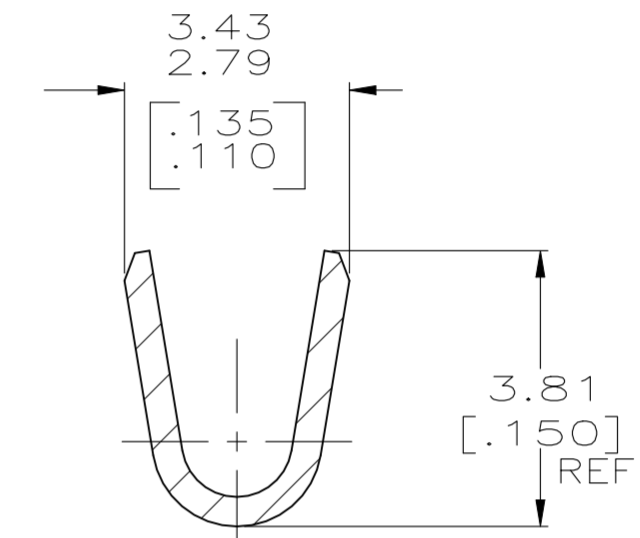

SECTION A-A
SCALE 10:1

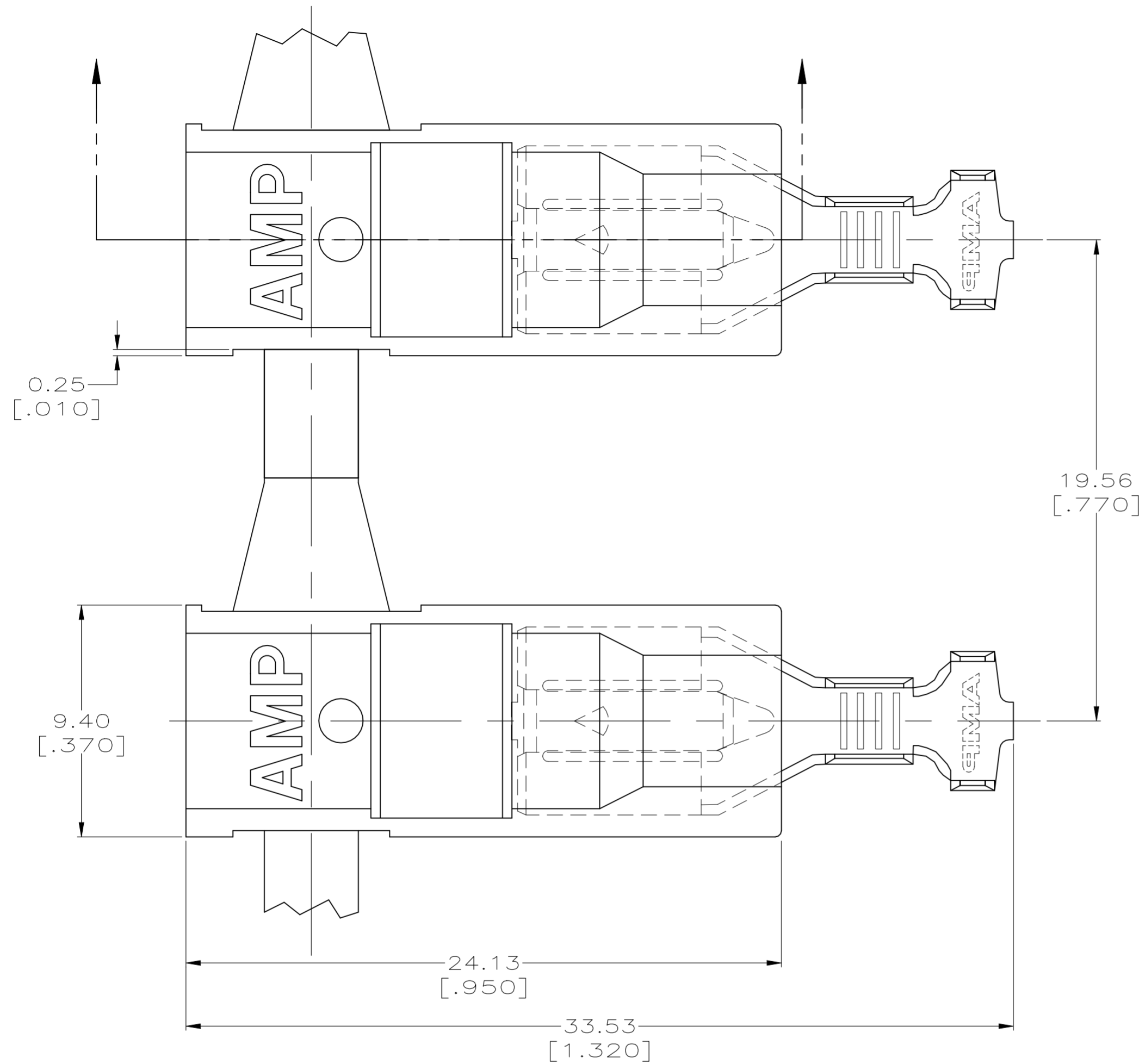
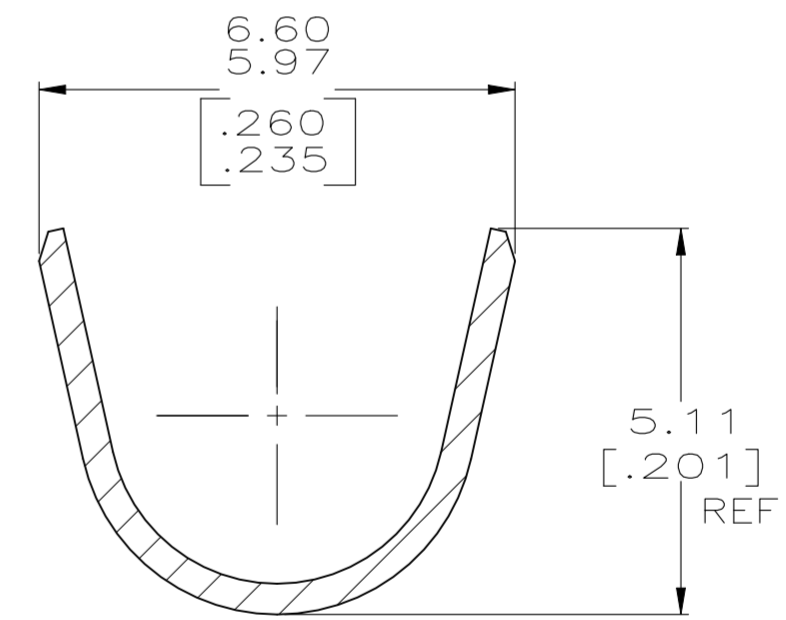

SECTION B-B
SCALE 10:1

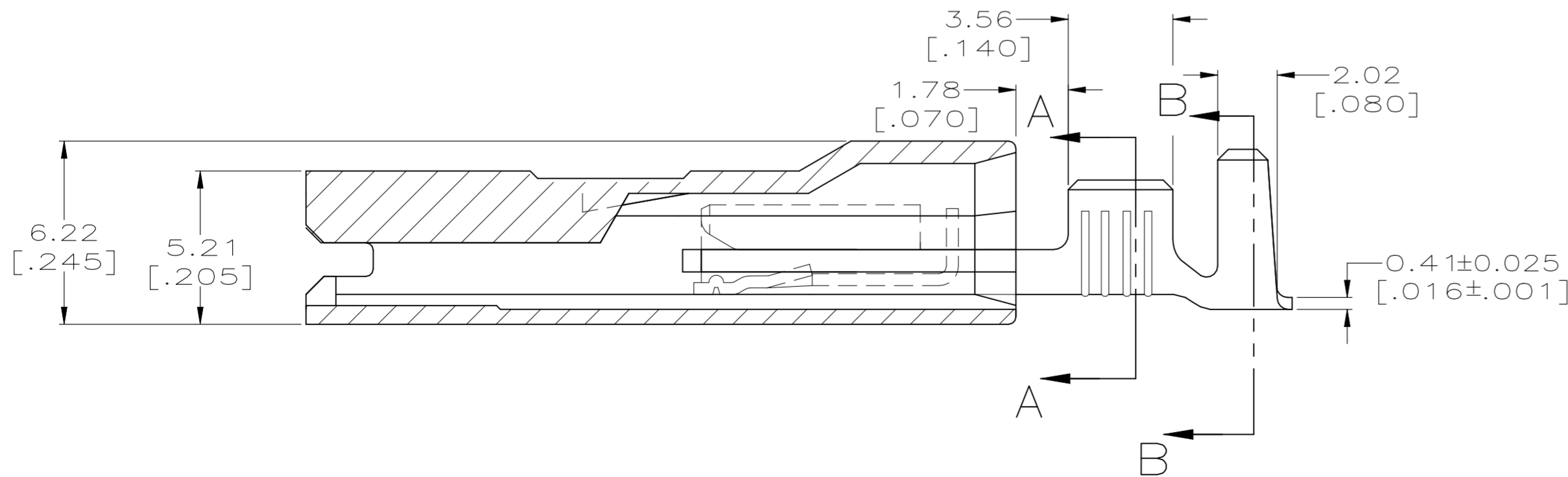

THIS DRAWING IS A CONTROLLED DOCUMENT.

DIMENSIONS: mm [INCHES]	TOLERANCES UNLESS OTHERWISE SPECIFIED:
	0 PLC ± -
	1 PLC ± -
	2 PLC ± 0.25 [.010]
	3 PLC ± -
	4 PLC ± -
	ANGLES ± -
MATERIAL TERMINAL - BRASS HOUSING - 6/6 VO NYLON	FINISH TERMINAL - SEE TABLE HOUSING - NATURAL

DWN JR RUTH 19JUN00	19JUN00		NAME	ASSEMBLY, RECEPTACLE, ULTRA-POD, 6.35 [.250] SERIES
CHK MS FEHER 19JUN00	19JUN00		SIZE	A2
APVD J HUMMEL 19JUN00	19JUN00		CAGE CODE	00779
PRODUCT SPEC	APPLICATION SPEC		DRAWING NO	C=521317
WEIGHT	0.000000	RESTRICTED TO	-	
CUSTOMER DRAWING	SCALE	5:1	SHEET	1 of 1
			REV	C1