

Rev 0.1 Original  
 Rev 0.2 5/23/06, S.Delano, Renumbered P1 (MGA) to match the PCB MGA numbering.  
 Rev 0.3 5/24/06, DFK - Renumbered reference designators to match the Neutron schematic.  
 Rev 0.4 5/24/06, S.Delano - P1 was 24 pos., PDCR-9323\*\* was PDCR9324\*\*

### Proton NON-QFN POD Schematic

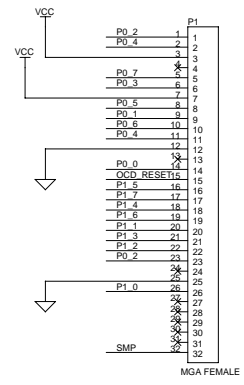

MGA used on this assembly has only 24 positions, PCB lands can accept 32 position MGA.

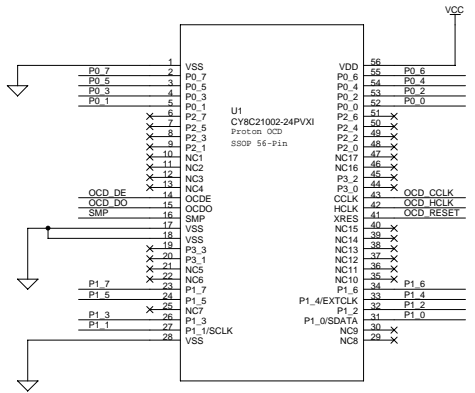
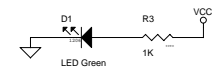
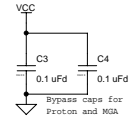
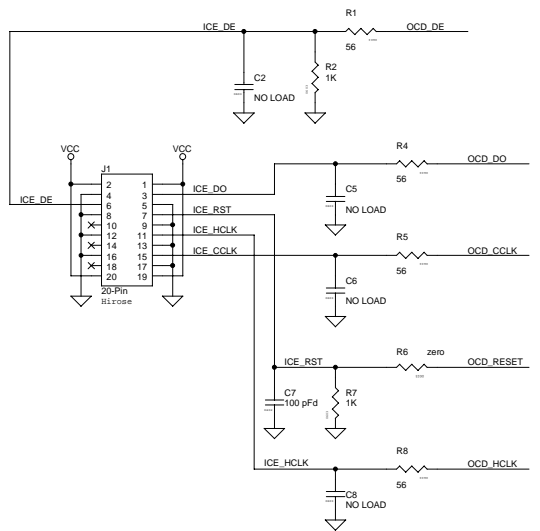

PCB: PDCR-9323 \*\*  
 PCA: 121R-32400 \*\*

<b>CYPRESS SEMICONDUCTOR © 2005</b>		
Proton Non-QFN POD		
Size C	Document Number REF-13504	Rev 0.3
Date: Wednesday, May 24, 2006	Sheet 1	of 1