

SPARK SR1010 & SR1020 – Ultra Low Power & Short Latency Wireless Transceivers

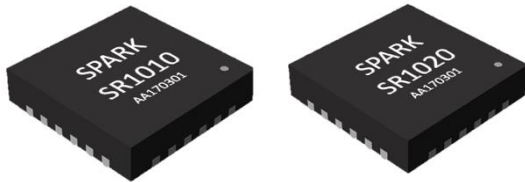
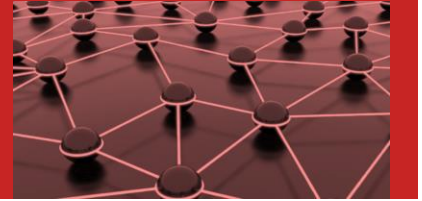

The SR1010/SR1020 is a highly versatile integrated short-range wireless transceiver that features ultra-low power consumption and ultra-short latency. It also allows for high data rate communications and features signals that are difficult to intercept. This transceiver communicates in the license-free ultra-wideband (UWB) spectrum from 3.1 - 9.25 GHz, enabling highly robust and energy efficient communications.

Features

- Dynamically reconfigurable UWB spectrum with up to 3 GHz of bandwidth
 - SR1010: 3.1 - 5.75 GHz band
 - SR1020: 6 - 9.25 GHz band
 - Up to 10 dBm peak TX power
- Ultra-short latency: 50 μ s airtime for 1 kb
- High quality of service
 - Capable of 3 ms audio latency for uncompressed 48 kSps 16-bit stereo audio streaming (1.54 Mbps payload)
- Scalable data rate up to 20.48 Mbps
- Time of flight-based distance measurement capability
 - 30 cm accuracy from 0.5 to 100 m
- Ultra-low power consumption
- Down to 0.25 nJ/bit TX energy efficiency and 1.15 nJ/bit RX energy efficiency
 - Sub-mW TX at 2.83 Mbps
 - Sub-mW RX at 0.85 Mbps
 - Energy efficient down to a few kbps
 - 55 nA hibernate, 750 nA deep sleep (with link synchronization)
 - 1.7 to 3.6 V supply
- Coexistence and non-interference with BLE / WiFi (2.4 & 5 GHz) and cellular
- 50 m range @ 5.5 Mbps
- 100 m range @ 600 Kbps
- Low power and low-cost timing using a 32.768 kHz crystal
- Industrial operating range: -40 to +85 °C
- Compact 4 x 4 mm 28 pin QFN
- Integrated baseband and modem
- Independent 1kb TX and 1kb RX FIFOs
- SPI Interface

Ultra-low power consumption for enhanced battery life

The battery life of wireless devices is often insufficient, leading to overly frequent recharge cycles, limited connectivity, bulky batteries and costly maintenance. The SR1010/SR1020 is aggressively duty cycled in order to achieve orders of magnitude better energy efficiency. When compared with current Bluetooth low energy (BLE) solutions, a 20X improvement in energy efficiency is obtained, yielding ultra-low power consumption. Moreover, the ultra-low power consumption is well-suited to operation with energy harvesting technologies.

Ultra-low latency for real-time communications

The high latency of current technologies is an obstacle to the development of multiple real-time applications. The SR1010/20 reduces link latency and enables wired systems that have been traditionally unable to use wireless technology to transition to a wireless link. Its ultra-short latency, in the μ s-scale (60X shorter than BLE), makes it suitable in applications where other wireless technologies cannot meet stringent timing requirements.

Scalable data-rate for versatile communications

Current low-power wireless solutions significantly restrict the amount of data that systems can transmit. The SR1010/20 can achieve ultra-low power consumption over a wide range of data rates, making it a highly versatile solution for many applications. Its raw data rate can be continuously scaled from 1 kbps up to 10 Mbps, enabling high throughput applications such as audio/video.

Reconfigurable spectrum that is robust and secure

Coexistence and interference robustness are often not well served by current wireless technologies, making wireless links less robust. The Spark Radio allows for dynamic shaping of its output spectrum to comply with international UWB emission limits and to customize its emissions to meet a wide range of spectral masks. The receiver is designed to reject narrow-band signals, such as WIFI or BLE, and the very low transmitted emission levels are inherently difficult to intercept, enhancing wireless security.

Ranging Capability

In addition to communicating data, the SR1000 family of UWB transceivers can make accurate distance measurements (i.e. ranging) between two SPARK chips. This is done by leveraging a unique ultra-low power time-of-flight (ToF) measurement architecture. Time of flight ranging is much more robust than typical ranging methods based on received signal strength as it relies on the time for the RF signal to transit between two chips and is not affected as much by occlusions between the chips. SPARK’s ranging system provides a 30 cm distance measurement accuracy. The system can operate from 0.5 m up to 100 m in line of sight. SPARK’s technology uniquely allows for microwatt-scale time of flight ranging, opening the door to extended battery life or battery-less (i.e. energy harvested) real-time positioning systems.

SR1000 - Block Diagram

The SR1010/SR1020 is composed of an UWB RF transmitter and receiver, a power management unit, a sleep counter, digital baseband hardware, timers and a regulator. It can be easily integrated with any microcontroller via an SPI interface. It can provide a significant increase in the battery life of systems.

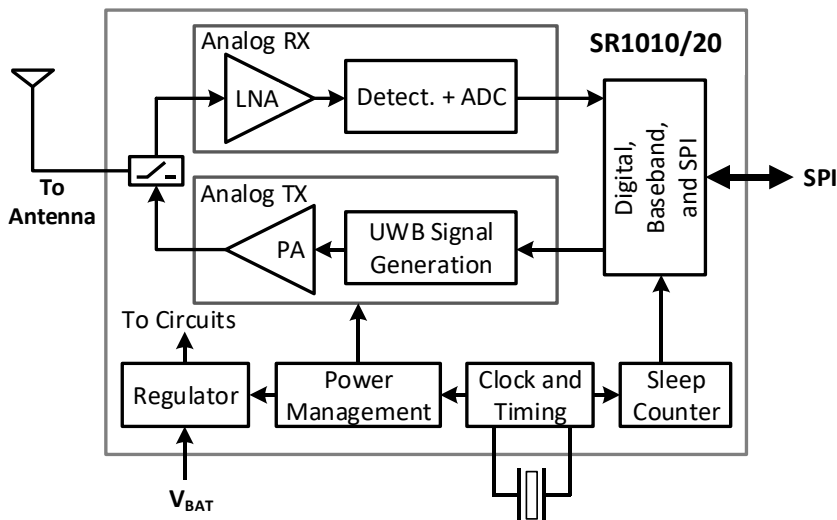

Battery lifetime comparison for audio streaming apps

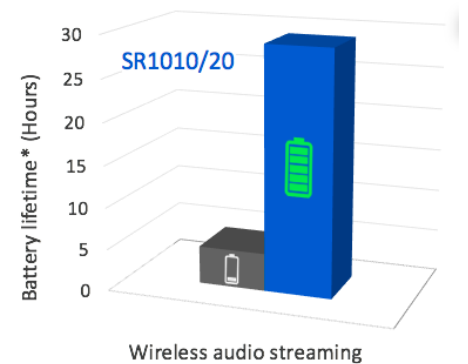

Key benefits

- Ultra short latency communication
 - Ideal for real-time data streams
- Ultra-low power
 - Battery-less operation with energy harvesting
 - Coin cell battery operation for many years
- Low system cost
 - High efficiency PCB antenna reference designs available
 - Low cost BOM
- Configuration and link layer software included
- Supports device-to-device, star, and mesh networks
- An eval kit is available and includes application demos and an API

Package Information (*)

PART NUMBER	PACKAGE	BODY SIZE	QUANTITY
SR1010-28QFN	QFN28	4x4mm	1
SR1010-28QFN-TR	QFN28	4x4mm	4000
SR1020-28QFN	QFN28	4x4mm	1
SR1020-28QFN-TR	QFN28	4x4mm	4000

(*) For more information, please go to sparkmicro.com/support

About SPARK Microsystems



SPARK Microsystems is a fabless semiconductor company that is leading the way towards ultra-low power wireless communications for the Internet of Things revolution. With its patented technologies, SPARK Microsystems is bringing to market a high-performance wireless transceiver that allows for orders of magnitude improved power consumption and latency while providing higher data rates than competing technologies. For more information, please visit www.sparkmicro.com.

North American Headquarters:
 1501 rue Barré, suite 201, Montréal, QC, Canada, H3C 4J1
 T: 1-438-375-3990 | info@sparkmicro.com