

REVISIONS					
P	LTR	DESCRIPTION	DATE	DMN	APVD
N		REVISED AS PER ECN-22-176726	27SEP2022	KK	AK

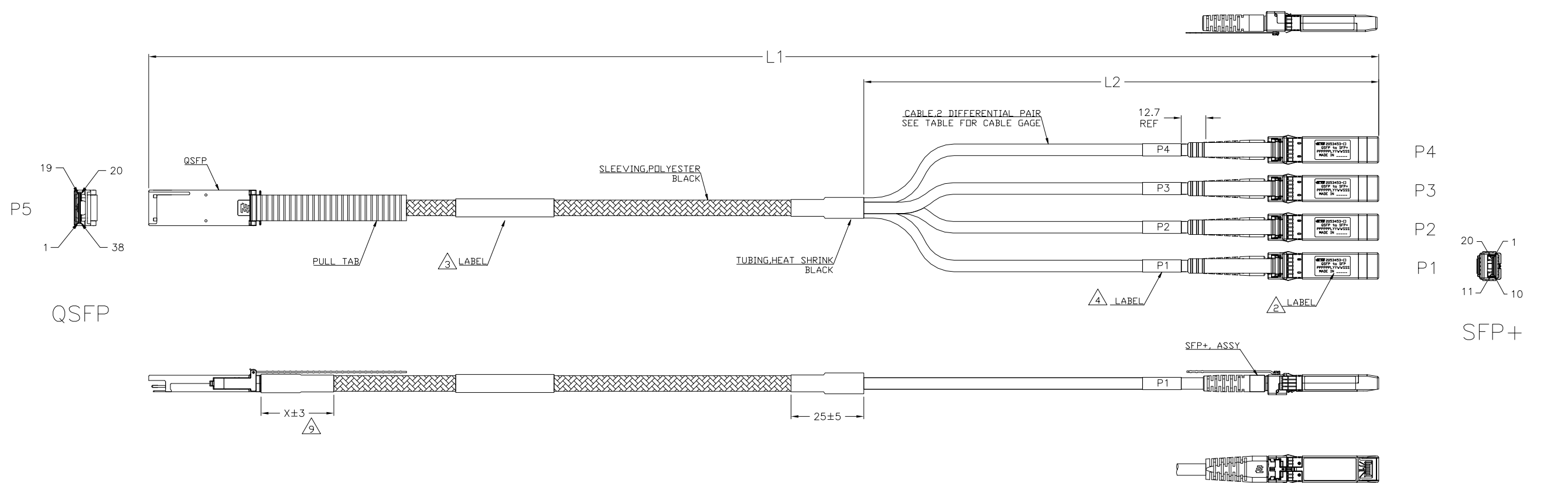

- CHARACTERISTIC IMPEDANCE: 100±10 OHMS (MEASURED DIFFERENTIALLY)
- LABEL INFORMATION:

	TE P/N
	SERIAL NUMBER: P[] SFP+
- LABEL INFORMATION:

	TE P/N
	SERIAL NUMBER: P[] SFP+
	MADE IN
- LABEL INFORMATION:

	APPROPRIATE "P" NUMBER
--	------------------------

- CABLE ASSEMBLY TO BE TESTED FOR CONTINUITY, OPENS, SHORTS AND PROPER EEPROM PROGRAM.
- SEE SHEET 2 FOR WIRING DIAGRAM.
- PRODUCT AND PROCESSING MEETS THE REQUIREMENTS OF TE STANDARD TEC-138-702.
- SERIAL NUMBER BEGINS WITH 001 AT THE BEGINNING OF EACH WEEK.
- SEE TABLE FOR HEAT SHRINK TUBE LENGTH.

OBSOLETE	35	26 AWG	1000±25	4000 ⁺⁸⁰ ₋₀	1-2053453-3
OBSOLETE	35	26 AWG	1000±25	3500 ⁺⁸⁰ ₋₀	1-2053453-2
OBSOLETE	35	26 AWG	1000±25	3000 ⁺⁸⁰ ₋₀	1-2053453-1
OBSOLETE	35	26 AWG	1000±25	4500 ⁺⁸⁰ ₋₀	1-2053453-0
	50	30 AWG	1000±25	1500 ⁺⁵⁰ ₋₀	2053453-8
	50	30 AWG	1000±25	2500 ⁺⁸⁰ ₋₀	2053453-7
OBSOLETE	35	26 AWG	1000±25	5000 ⁺⁸⁰ ₋₀	2053453-6
	50	28 AWG	1000±25	4000 ⁺⁸⁰ ₋₀	2053453-5
	50	30 AWG	1000±25	3000 ⁺⁸⁰ ₋₀	2053453-4
	50	30 AWG	1000±25	2000 ⁺⁸⁰ ₋₀	2053453-3
	50	30 AWG	500±25	1000 ⁺⁵⁰ ₋₀	2053453-2
	50	30 AWG	250±25	500 ⁺⁵⁰ ₋₀	2053453-1
	"X"	CABLE GAGE	L2	L1	PART NO

THIS DRAWING IS A CONTROLLED DOCUMENT.

DIMENSIONS:	mm	0 PLC ±	1 PLC ±	2 PLC ±	3 PLC ±	4 PLC ±	ANGLES ±	MATERIAL	FINISH	WEIGHT	0	SIZE	A1	CAGE CODE	00779	DRAWING NO	C-2053453	RESTRICTED TO	
-------------	----	---------	---------	---------	---------	---------	----------	----------	--------	--------	---	------	----	-----------	-------	------------	-----------	---------------	--

TE Connectivity Ltd.

REVISIONS				
P	LTR	DESCRIPTION	DATE	APVD
-	-	SEE SHEET 1	-	-

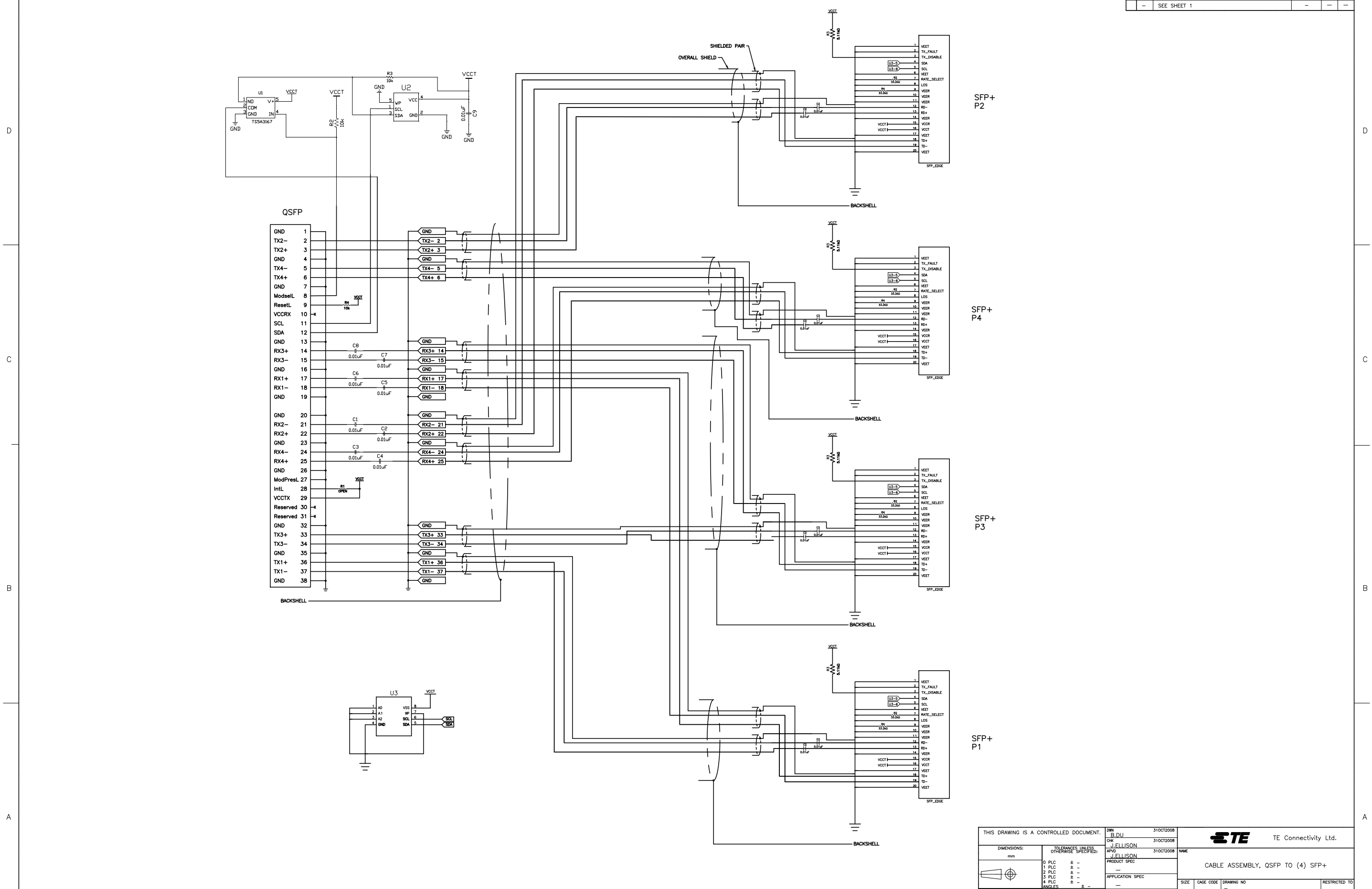

THIS DRAWING IS A CONTROLLED DOCUMENT.		DWN	B.DU	31OCT2008
DIMENSIONS:		CHK	J.ELLISON	31OCT2008
mm		APVD	J.ELLISON	31OCT2008
TOLERANCES UNLESS OTHERWISE SPECIFIED:		NAME		
0 PLG	±	PRODUCT SPEC		
1 PLG	±	APPLICATION SPEC		
2 PLG	±	SIZE		
3 PLG	±	CAGE CODE		
4 PLG	±	DRAWING NO		
ANGLES	±	RESTRICTED TO		
MATERIAL	-	WEIGHT	-	-
FINISH	-	A1 00779 C-2053453		SCALE 1:1 SHEET 2 OF 2 REV N
CUSTOMER DRAWING				