

Product Specifications

Customer	Standard
Description	10.2" TFT EPD Panel
Model Name	EZ102CT011
Date	2014/12/10
Doc. No.	1P074-00
Revision	01

Customer Approval	
Date	
The above signature represents that the product specifications, testing regulation, and warranty in the specifications are accepted	

	Design Engineering		
	Approval	Check	Design

No.71, Delun Rd., Rende Dist., Tainan City 71743, Taiwan (R.O.C.)

Tel: +886-6-279-5399

Fax: +886-6-270-5857

Copyright

Pervasive Displays Incorporated All rights reserved.

This document is the exclusive property of Pervasive Displays Inc. (PDI) and shall not be reproduced or copied or transformed to any other format without prior permission of PDI. (PDI Confidential)

本資料為龍亭新技股份有限公司專有之財產，非經許可，不得複製、翻印或轉變成其他形式使用。

龍亭新技股份有限公司 Pervasive Displays Inc.

No.71, Delun Rd., Rende Dist., Tainan City 71743, Taiwan (R.O.C.)

Tel: +886-6-279-5399

<http://www.pervasivedisplays.com>

Table of Contents

Revision History	6
Glossary of Acronyms	7
1 General Description	8
1.1 Overview	8
1.2 Features	8
1.3 Applications	8
1.4 General Specifications	9
1.5 Mechanical Specifications.....	10
2 Absolute Maximum Ratings.....	12
2.1 Absolute Ratings of Environment	12
2.2 Reliability Test Item	13
3 Electrical Characteristics.....	14
3.1 Absolute Maximum Ratings of Panel	14
3.2 Recommended Operation Conditions of Panel	14
3.3 Source driver Ac characteristics	15
3.4 Gate driver AC characteristics	16
3.5 Power ON/OFF sequence.....	17
4 Application Circuit Block Diagram	18
5 Panel Pin Assignment.....	19
5.1 Terminal Pin Assignment.....	19
6 Optical Characteristics.....	21
6.1 Test Conditions.....	21
6.2 Optical Specifications	21
6.3 Ghosting.....	24
7 Packing	25
8 Precautions.....	27
9 Definition of Labels.....	29

List of Figures

Figure 1-1 EPD Drawing 11

Figure 2-1 Operating Range of Relative Humidity and Temperature 12

Figure 4-1 Application Circuit Block Diagram 18

Figure 6-1 Optical measurement..... 22

Figure 6-2 Definition of Viewing Angle to Measure Contrast Ratio 23

Figure 7-1 Packing Diagram 25

Figure 9-1 Model Labels..... 29

Figure 9-2 Definition of Model Labels..... 30

Figure 9-3 Carton Label 31

Figure 9-4 Pallet Label 31

List of Tables

Table 1-1 General Specification 9
Table 1-2 EPD Mechanical Specification 10
Table 1-3 FPC Specification 10
Table 2-1 Absolute Ratings of Environment 12
Table 2-2 Reliability Test Item..... 13
Table 3-1 Absolute Maximum Ratings of Panel 14
Table 3-2 Recommended Operation Conditions of Panel 14
Table 5-1 Terminal Pin Assignment 19
Table 6-1 Optical Test Conditions 21
Table 6-2 Optical Measurement with D65 light source 21

Revision History

Version	Date	Page (New)	Section	Description
Ver.01	2014/12/10	All	All	Specification first issued.

Glossary of Acronyms

EPD	Electrophoretic Display (e-Paper Display)
EPD Panel	EPD
EPD Module	EPD with TCon board
TCon	Timing Controller
TFT	Thin Film Transistor
MCU	Microcontroller Unit
FPC	Flexible Printed Circuit
FPL	Front Plane Laminate
SPI	Serial Peripheral Interface
COG	Chip on Glass
PDI	Pervasive Displays Incorporated

1 General Description

1.1 Overview

This is a 10.2" a-Si TFT active matrix Electronic Paper Display (EPD) module. Since this module has high resolution, 160dpi, it can display fine pattern easily. Additionally, this module needs not only no power while hold pattern due to the bi-stable character of EPD but also ultra low power to update pattern.

1.2 Features

- a-Si TFT active matrix Electronic Paper Display(EPD)
- Resolution: 1024 x 1280
- Ultra low power consumption
- Super Wide Viewing Angle - near 180°
- Extra thin & light
- SPI interface
- RoHS compliant

1.3 Applications

- e-POP/Signage
- Electronic bulletins
- Office Automation
- Navigator

1.4 General Specifications

Table 1-1 General Specification

Item	Specification	Unit	Note
Outline Dimension	171.76(H) x 218.30(V) x 1.20(T)	mm	(1)
Active Area	162.56(H) x 203.20(V)	mm	
Driver Element	a-Si TFT active matrix	-	
FPL	Aurora Mb	-	
Pixel Number	1024 x 1280	pixel	
Pixel Pitch	0.15875 x 0.15875 (160dpi)	mm	
Pixel Arrangement	Vertical stripe	-	
Display Colors	Black/White	-	
Surface Treatment	Anti-Glare	-	

Note (1): Not including the FPC.

1.5 Mechanical Specifications

Table 1-2 EPD Mechanical Specification

Item		Min.	Typ.	Max.	Unit	Note
Glass Size	Horizontal(H)	171.46	171.76	172.06	mm	
	Vertical(V)	218.00	218.30	218.60	mm	
	Thickness(T)	1.0	1.2	1.4	mm	(1)
Weight			91.7	110	g	

Note (1): Not including the Masking Film.

Table 1-3 FPC Specification

Item	Pin numbers	Pitch (mm)	Connector	Note
Board to Board Connector	40		HRS DF23C-40DP-0.5V	

Figure 1-1 EPD Drawing

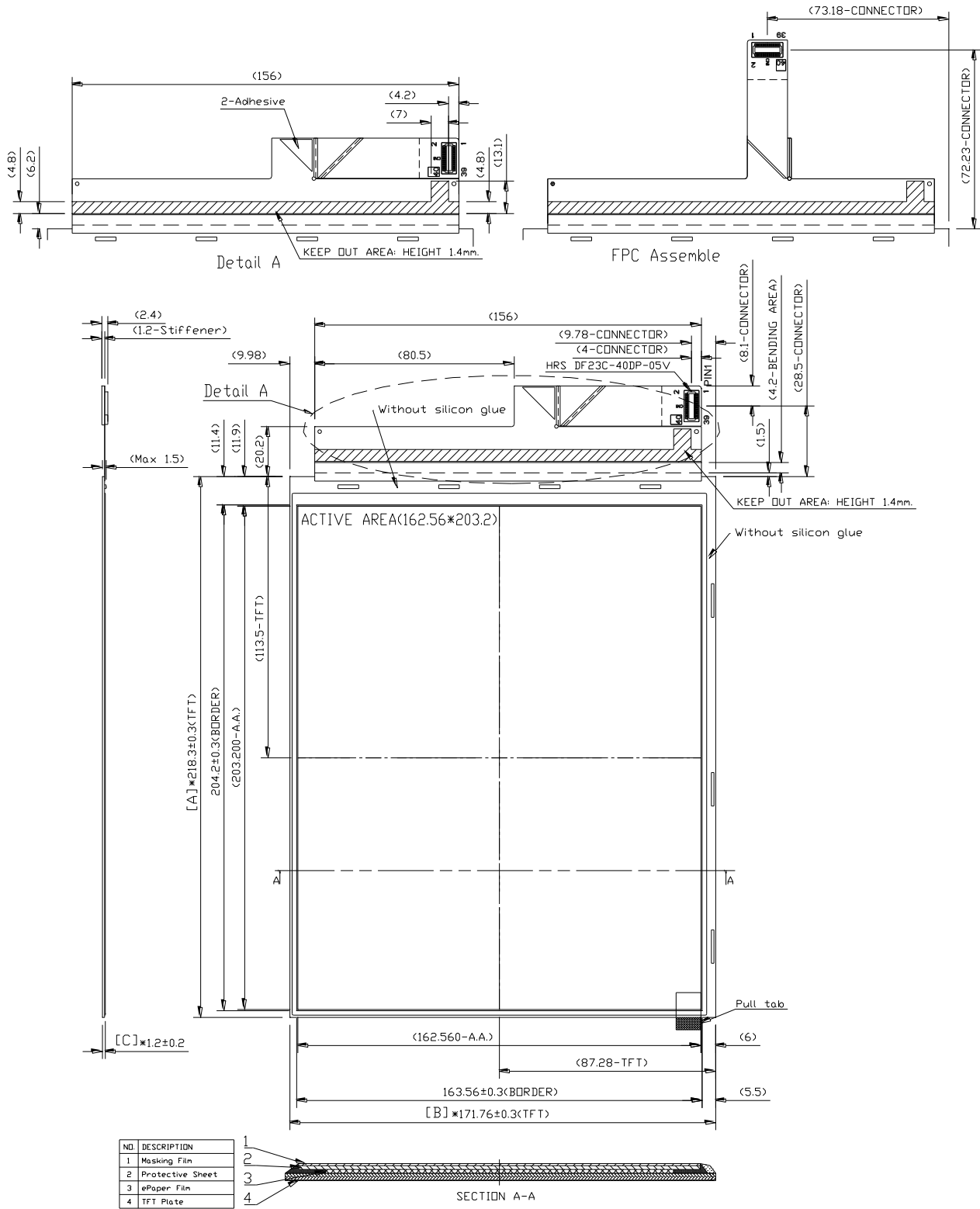

2 Absolute Maximum Ratings

2.1 Absolute Ratings of Environment

Table 2-1 Absolute Ratings of Environment

Item	Symbol	Value		Unit	Note
		Min.	Max.		
Storage Temperature	T _{ST}	-20	+60	°C	(1),(3)
Operating Ambient Temperature	T _{OP}	0	+50	°C	(1),(2),(3)

Note (1):

- (a) 90 %RH Max. (Ta ≤ 40 °C).
- (b) Wet-bulb temperature should be 39 °C Max. (Ta > 40 °C).
- (c) No condensation and no frost.

Note (2): The temperature of panel display surface area should be 0 °C Min. and 50 °C Max. Refresh time depends on operating temperature.

Note (3): In order to keep good performance of EPD, please refer to precaution for storage condition.

Figure 2-1 Operating Range of Relative Humidity and Temperature

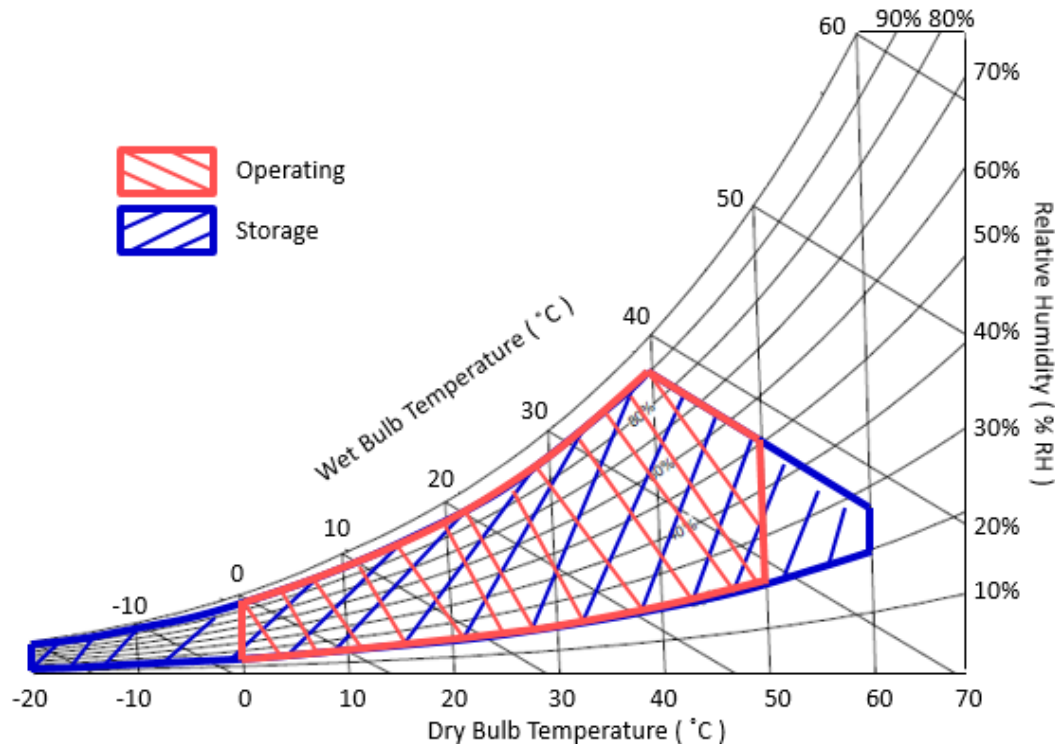

2.2 Reliability Test Item

Table 2-2 Reliability Test Item

Item	Test Condition	Note
High Temperature Operation	50 °C / 30 %RH for 240h	(1) (2)
Low Temperature Operation	0 °C for 240h	(1) (2)
High Temperature/Humidity Operation	40 °C / 90 %RH for 168h	(1) (2)
High Temperature Storage	60 °C / 26 %RH for 240h	(1)(2)(3)
Low Temperature Storage	-20 °C for 240h	(1)(2)(3)
High Temperature/Humidity Storage	50 °C / 80 %RH for 168h	(1)(2)(3)
Thermal Cycles (Non-operation)	1 Cycle:-20°C/30min → 60°C/30min, for 100 Cycles	(1)(2)(3)
Package Drop Test	Drop from 97cm. (ISTA) 1 corner, 3 edges, 6 sides. One drop for each.	(1)(2)(3)
Package Random Vibration Test	1.15Grms, 1Hz ~ 200Hz. (ISTA)	(1)(2)(3)

Note (1): No condensation and no frost during test. End of test, function, mechanical, and optical shall be satisfied.

Note (2): The test result and judgment are based on PDI's 1bit driving waveform, driving fixture and driving system.

Note (3): Stay white pattern for storage and non-operation test.

3 Electrical Characteristics

3.1 Absolute Maximum Ratings of Panel

Table 3-1 Absolute Maximum Ratings of Panel

Parameter	Symbol	Rating	Unit
Logic supply voltage	V_{DD}	-0.3 to +7	V
Source positive supply voltage	V_{POS}	-0.3 to +20	V
Source negative supply voltage	V_{NEG}	+0.3 to -20	V
Max. drive voltage range	$V_{POS}-V_{NEG}$	40	V
Gate supply range	$V_{GG}-V_{EE}$	40	V
Operating temp. range		0 to +50	°C

$T_a = 25 \pm 2 \text{ }^\circ\text{C}$

3.2 Recommended Operation Conditions of Panel

Table 3-2 Recommended Operation Conditions of Panel

Parameter	Symbol	Value			Unit
		Min	Typ	Max	
Signal Ground	V_{SS}	-	0	-	V
Logic Power	V_{DD}	3.0	3.3	3.6	V
Source positive Voltage	V_{POS}	14	15	16	V
Source negative Voltage	V_{NEG}	-16	-15	-14	V
Gate positive Voltage	V_{GG}	$V_{POS}+5$	22	$V_{EE}+40$	V
Gate negative Voltage	V_{EE}	-21	-20	$V_{NEG}-5$	V
Common voltage	V_{COM}	-	-1.8	-	V

$T_a = 25 \pm 2 \text{ }^\circ\text{C}$

3.3 Source driver Ac characteristics

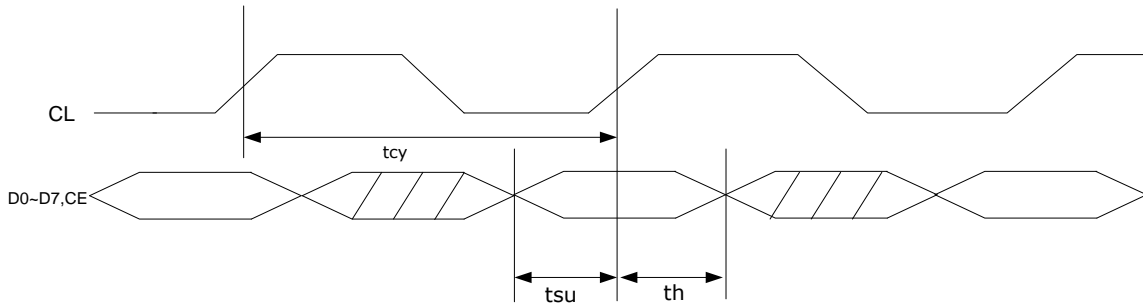

Parameter	Symbol	Min.	Typ.	Max.	Unit
Clock CL cycle time	t_{cy}	40	-	-	ns
D0...D7, CE setup time	t_{su}	8	-	-	ns
D0...D7, CE hold time	t_h	1	-	-	ns

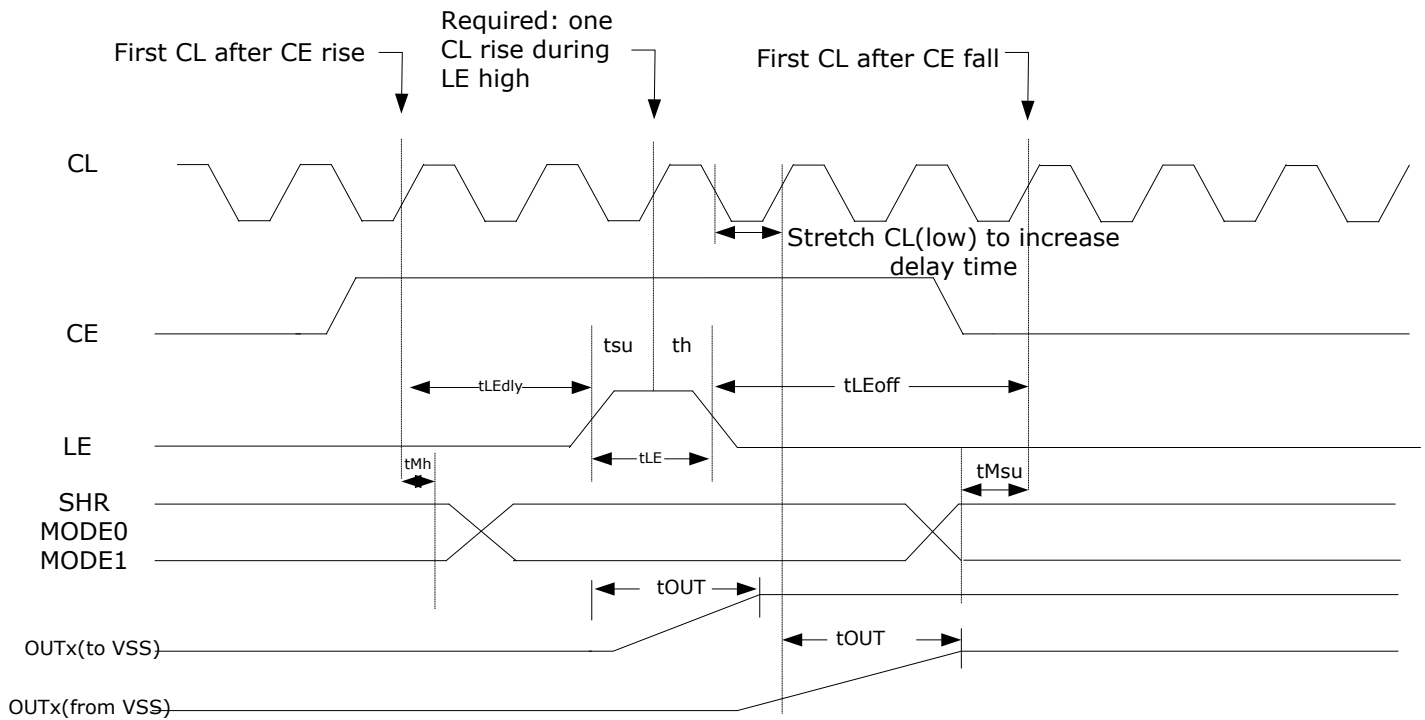

Parameter	Symbol	Condition	Min.	Typ.	Max.	Unit
LE on delay time	t_{LEdly}		40	-	-	ns
LE high-level pulse width	t_{LEw}		40	-	-	ns
LE off delay time	t_{LEoff}		40	-	-	ns
SHR,MODE0,MODE1 setup time	t_{Msu}		100	-	-	ns
SHR,MODE0,MODE1 hold time	t_{Mh}		10	-	-	ns
Output settling time to +/-30mV	t_{OUT}	$C_{load}=50pf$	100	-	12	us

3.4 Gate driver AC characteristics

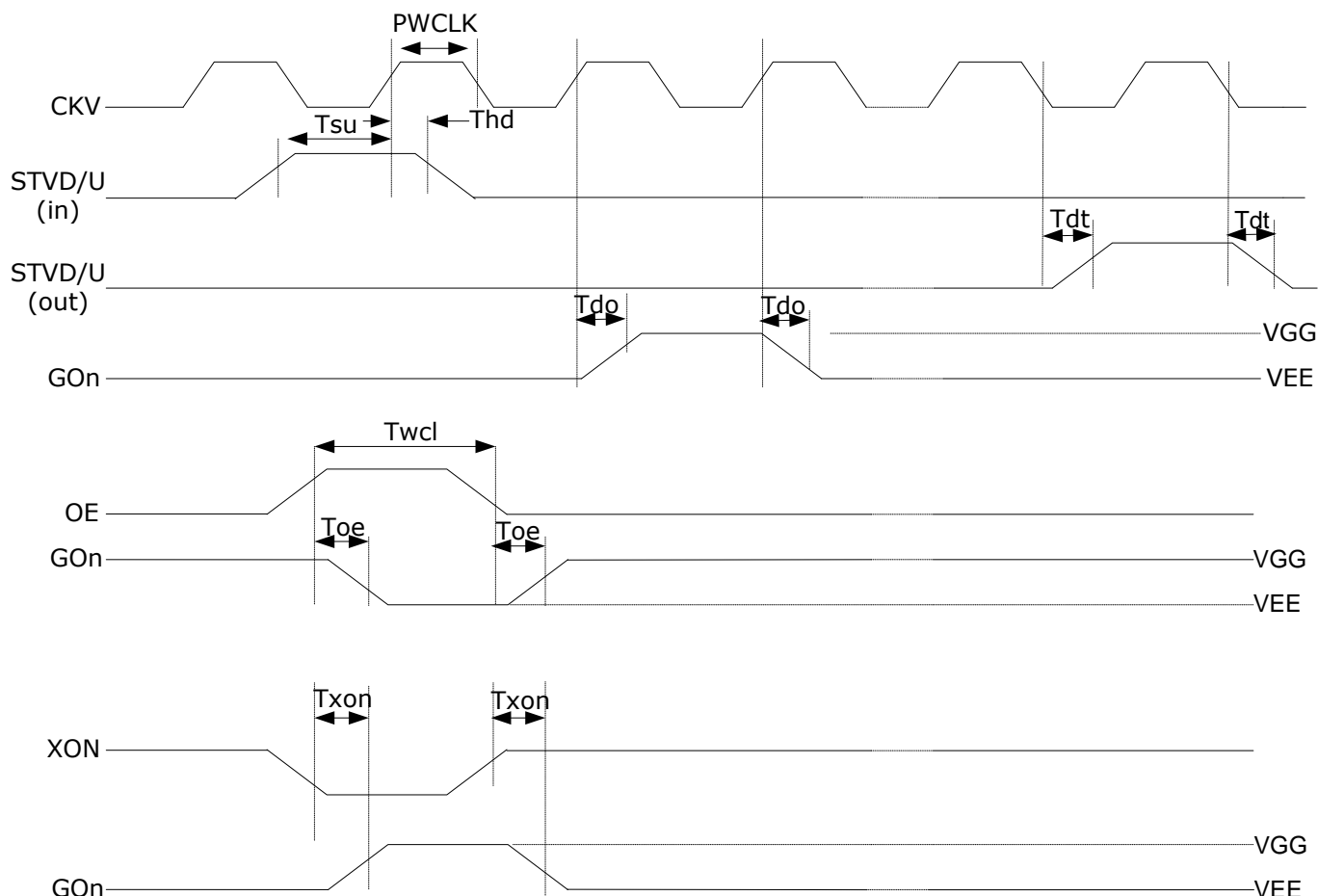

Parameter	Symbol	Condition.	Min.	Typ.	Max.	Unit
Clock pulse width(High to low period)	PWCLK		500			ns
STVD/STVU setup time	Tsu		200			ns
STVD/STVU hold time	Thd		300			ns
Driver output delay time	Tdo	CL=220pF			900	ns
STVD/STVU delay time	Tdt	CL=220pF			500	ns
Output enable pulse width	Twcl		1			us
OE to driver output delay time	Toe	CL=220pF			900	ns
XON to driver output delay time	Txon	CL=220pF			10	us

3.5 Power ON/OFF sequence

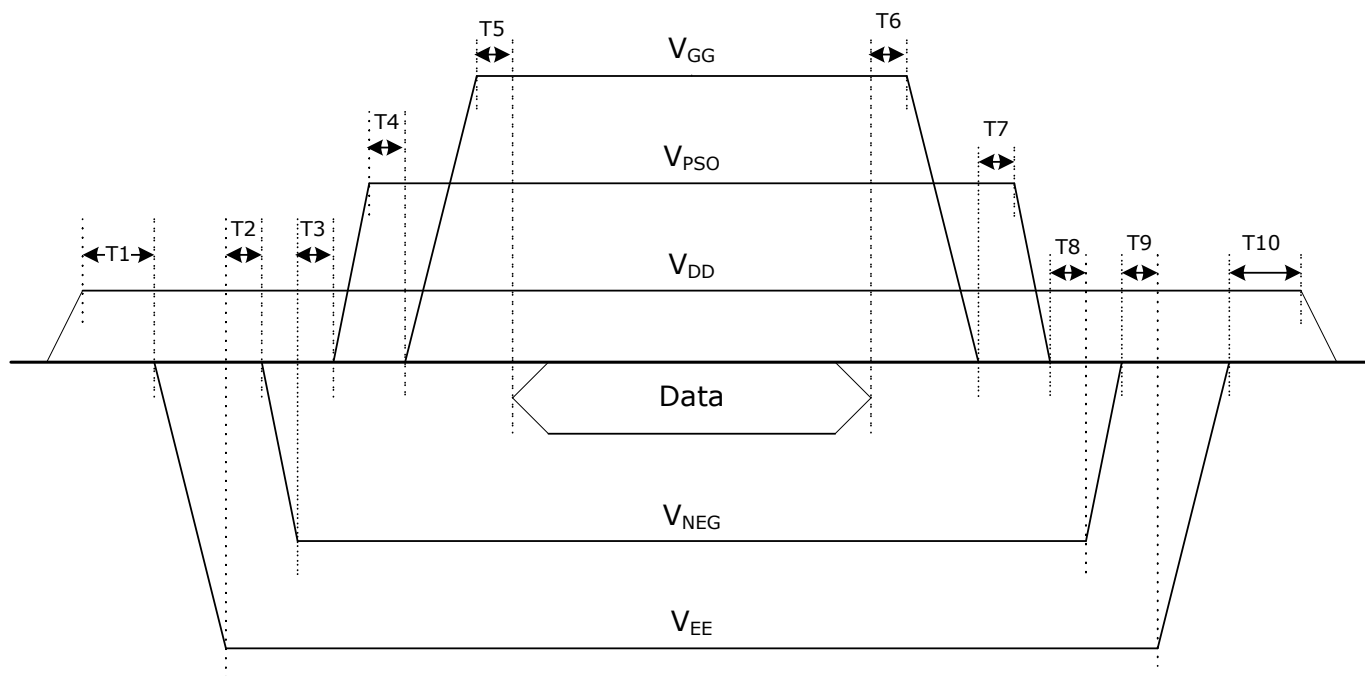

Symbol	Min.	Max.
T1	20 ms	-
T2	4 ms	-
T3	4 ms	-
T4	4 ms	-
T5	100 us	-
T6	100 us	-
T7	4ms	-
T8	4ms	-
T9	4ms	-
T10	20ms	-

4 Application Circuit Block Diagram

Figure 4-1 Application Circuit Block Diagram

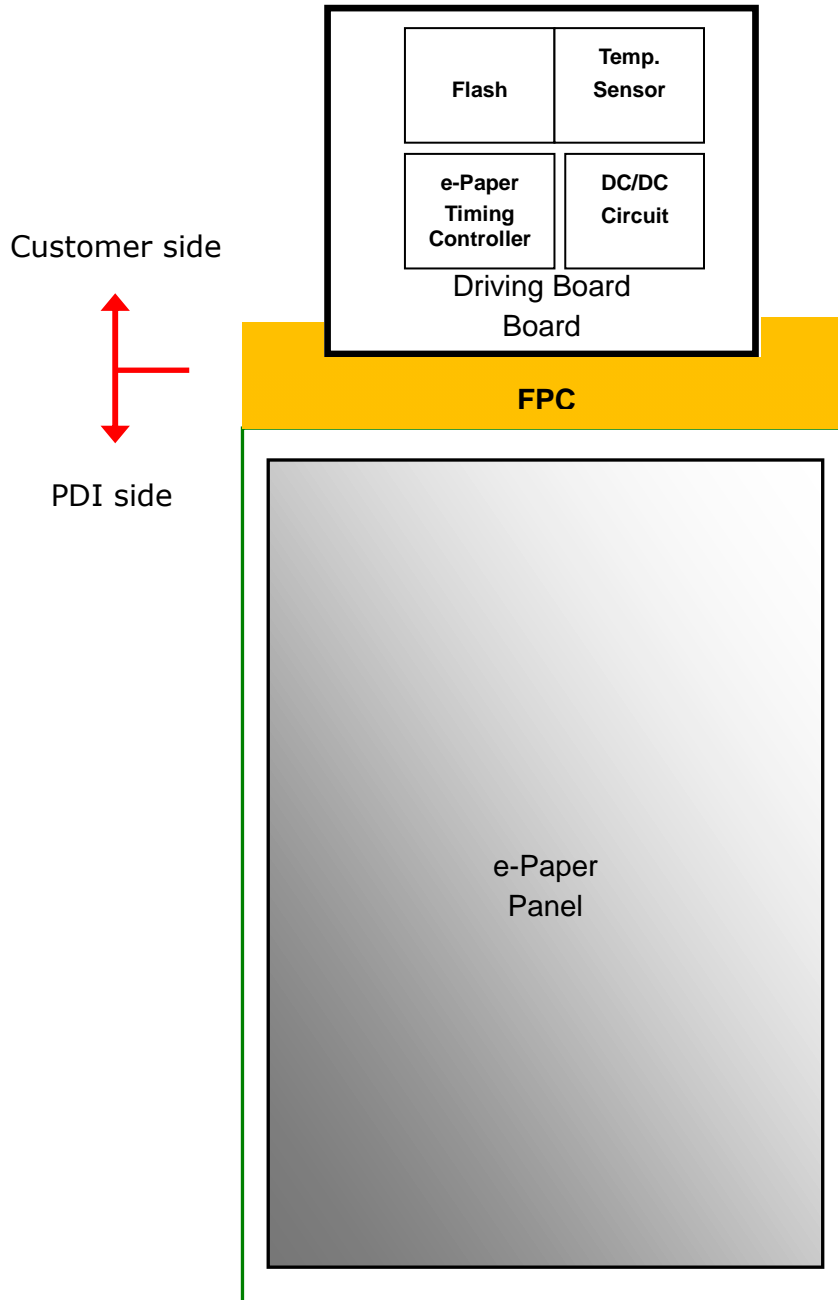

5 Panel Pin Assignment

5.1 Terminal Pin Assignment

Table 5-1 Terminal Pin Assignment

No.	Signal	Type	Connected to	Function
1	V _{NEG}	P	V _{NEG}	Source driver negative power supply
2	V _{POS}	P	V _{POS}	Source driver positive power supply
3	V _{NEG}	P	V _{NEG}	Source driver negative power supply
4	V _{POS}	P	V _{POS}	Source driver positive power supply
5	V _{NEG}	P	V _{NEG}	Source driver negative power supply
6	V _{POS}	P	V _{POS}	Source driver positive power supply
7	GND	P	Ground	Grounding
8	NC	-	Floating	
9	GND	P	Ground	Grounding
10	GND	P	Ground	Grounding
11	D0	I	MCU	Bit0 of the data bus
12	D1	I	MCU	Bit1 of the data bus
13	D2	I	MCU	Bit2 of the data bus
14	D3	I	MCU	Bit3 of the data bus
15	D4	I	MCU	Bit4 of the data bus
16	D5	I	MCU	Bit5 of the data bus
17	D6	I	MCU	Bit6 of the data bus
18	D7	I	MCU	Bit7 of the data bus
19	GND	P	Ground	Grounding
20	GND	P	Ground	Grounding
21	CE1	I	MCU	Chip Enable 1

No.	Signal	Type	Connected to	Function
22	CE2	I	MCU	Chip Enable 2
23	CE3	I	MCU	Chip Enable 3
24	CE4	I	MCU	Chip Enable 4
25	OE	I	MCU	Output enable
26	OE123L	I	MCU	Output enable 1, 2 and 3 (connected)
27	CL	I	MCU	Pixel Clock
28	LE	I	MCU	Latch enable
29	U/D	I	MCU	Gate scan direction
30	V _{COM}	P	V _{COM}	Common voltage (backplane)
31	CKV	I	MCU	Line clock
32	STVD	I/O	MCU / -	Gate start pulse. When U/D=1, the pin is input.
33	SHR	I	MCU	Source scan direction
34	STVU	I/O	MCU/ -	Gate start pulse. When U/D=0, the pin is input.
35	VST	P	V _{COM}	Common voltage (capacitor line)
36	V _{DD}	P	V _{DD}	Logic supply voltage
37	V _{EE}	P	V _{EE}	Gate driver negative power supply
38	V _{DD}	P	V _{DD}	Logic power supply
39	V _{GG}	P	V _{GG}	Gate driver positive power supply
40	NC	-	Floating	

Note (1): Type:

I: Input
 O: Output
 P: Power

6 Optical Characteristics

6.1 Test Conditions

Table 6-1 Optical Test Conditions

Item	Symbol	Value	Unit
Ambient Temperature	Ta	25±2	°C
Ambient Humidity	Ha	50±10	%RH
Supply Voltage	V _{CC} & V _{DD}	3.3	V

6.2 Optical Specifications

Table 6-2 Optical Measurement with D65 light source

Item	Symbol	Rating			Unit	Note
		Min.	Typ.	Max.		
Contrast ratio	CR	-	7:1	-	-	$\theta_x=\theta_y=0$ (1),(2),(3),(4)
Refresh time	Tr	-	3.2	-	sec	(3)
White Chromaticity	Wx	-	0.31	-	-	$\theta_x=\theta_y=0$ (1),(4)
	Wy	-	0.33	-		
Reflectance	R%		32	-	%	(1),(4)

Note (1): Panel is driven by PDI waveform without masking film and optical measurement by CM-700D with D65 light source and SCE mode.

Figure 6-1 Optical measurement

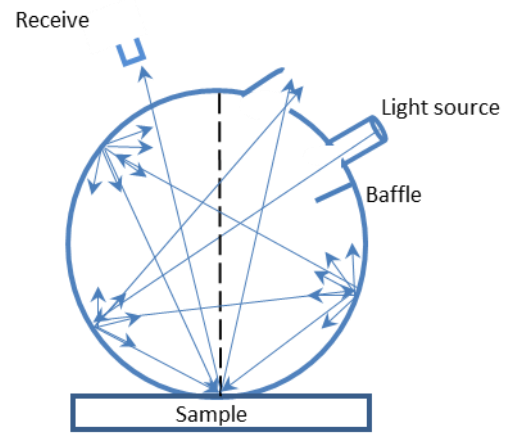
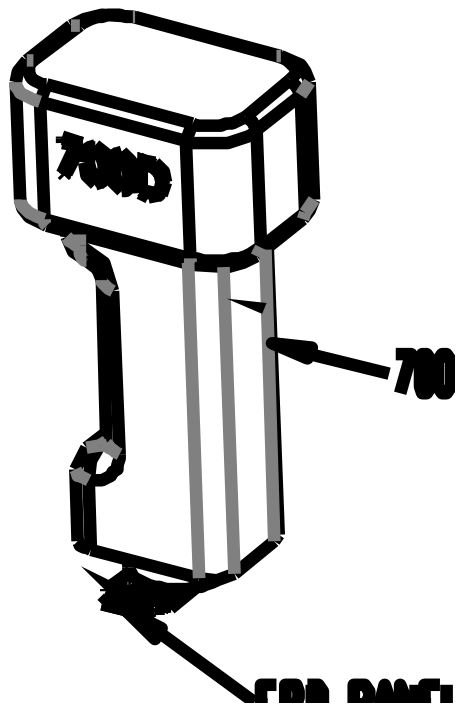

Note (2): Definition of Viewing Angle (θ_x, θ_y):

Figure 6-2 Definition of Viewing Angle to Measure Contrast Ratio

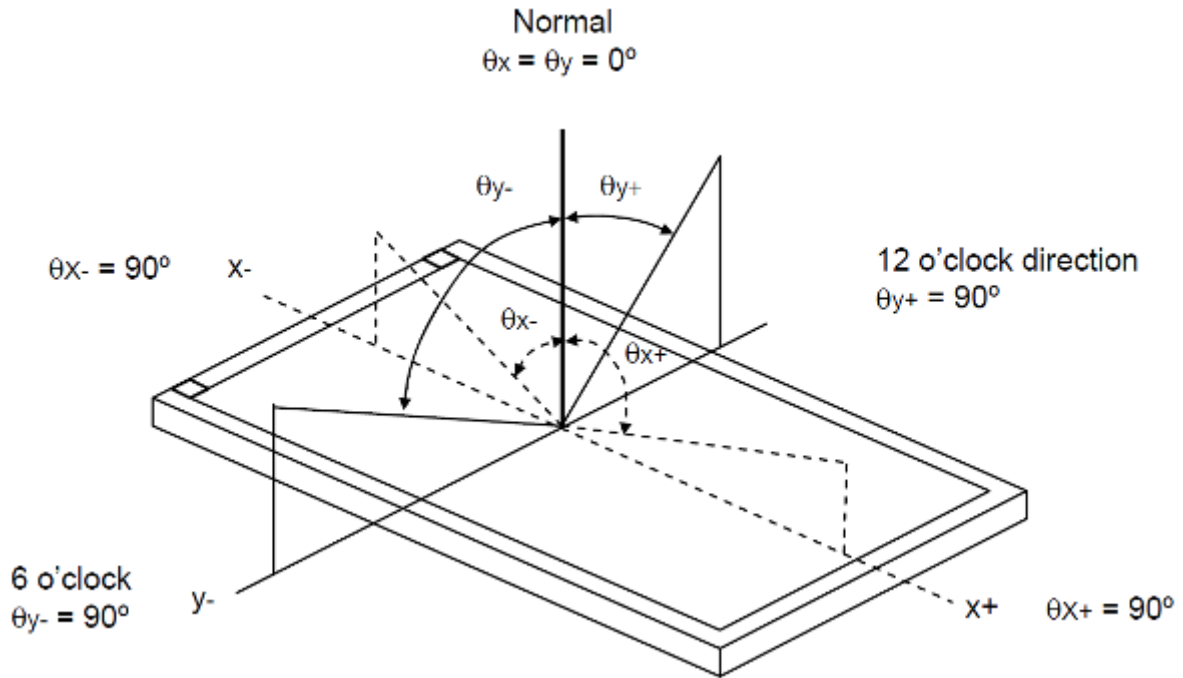

Note (3): Refresh time is the time that e-paper particles move not including the power on and off time. The refresh time is measured at 25°C. The refresh time and contrast ratio varies due to different films, display performance requirements, and ambient temperatures.

Note (4): Contrast ratio (C.R.): The Contrast ratio is calculated by the following expression. $C.R. = (R\% \text{ White}) / (R\% \text{ Black})$. Reflectance is measured at 120 seconds after refresh.

6.3 Ghosting

Below are two test methods to verify that ghosting within an acceptable range. Test 1 and Test 2 use measured data to calculate Delta E which is a single number representing the distance between two colors in a 3 dimensional color space. Test 1 and Test 2 are performed at 25°C.

- Test 1: White to Black Ghosting

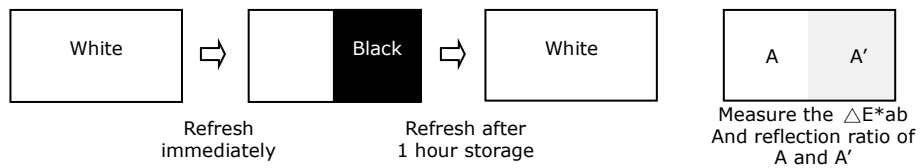

- Test 2: Black to White Ghosting

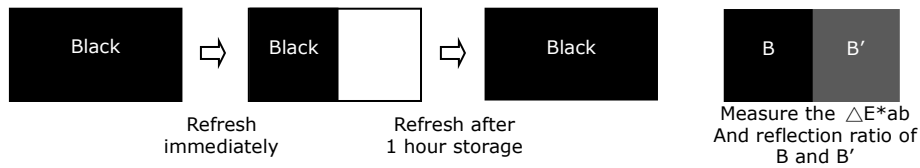

The formula is used to calculate Test1 and Test2. For example of Test 2:

$$\Delta E^*ab = [(L_B - L_{B'})^2 + (a_B - a_{B'})^2 + (b_B - b_{B'})^2]^{1/2}$$

Item	Rating		
	Min.	Typ.	Max.
Test 1 ΔE^*ab	-	-	2
Test 2 ΔE^*ab	-	-	2

Note: Panel is driven by PDI waveform without masking film and optical measurement by CM-700D with D65 light source and SCE mode.

7 Packing

Figure 7-1 Packing Diagram

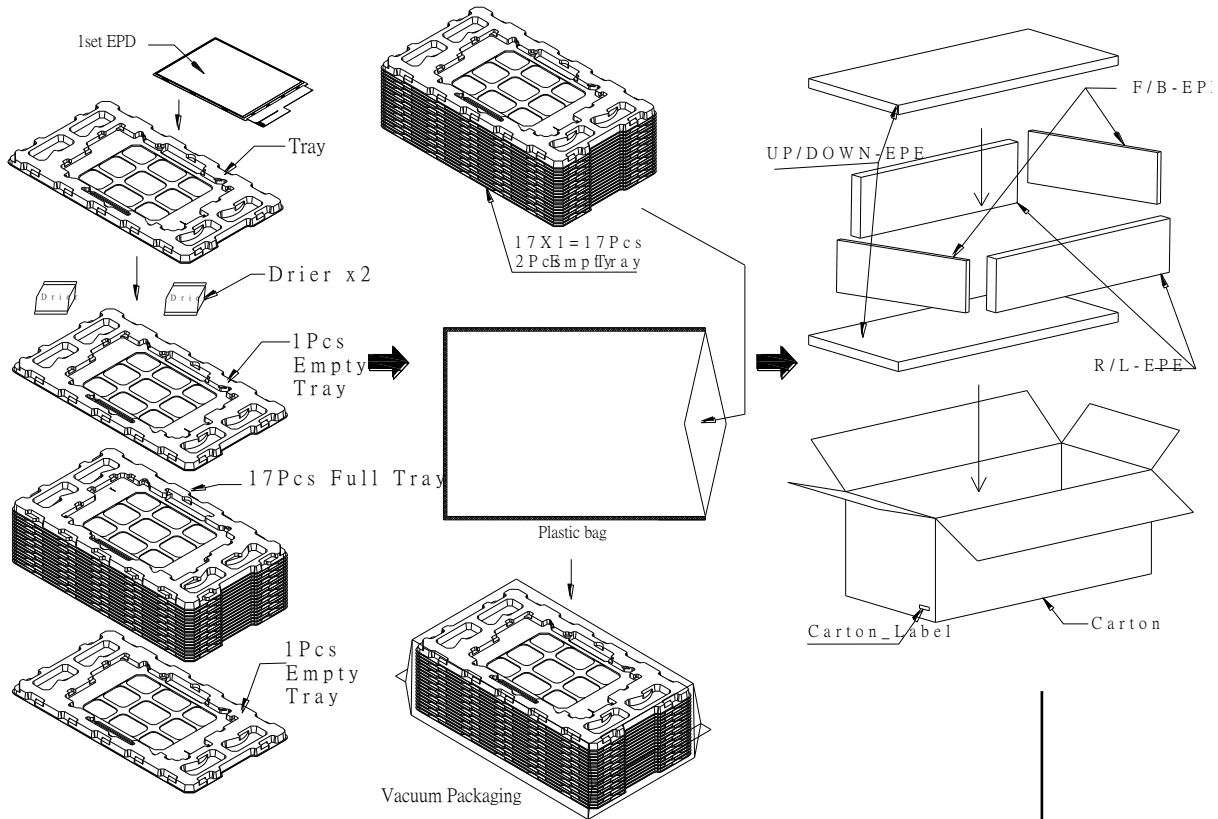

- Note: 1. Carton outline size: 500L X 300W X 200H mm
 2. Material of tray: A-PET
 3. Material of plastic bag: PE-LD

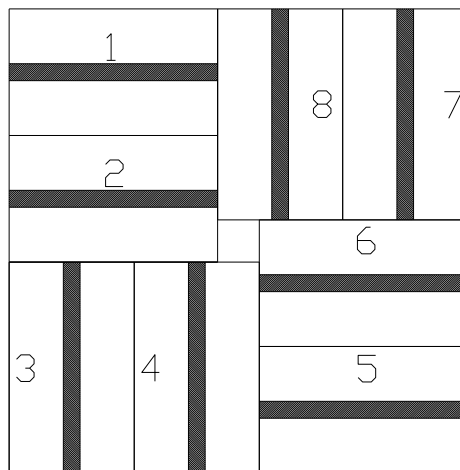

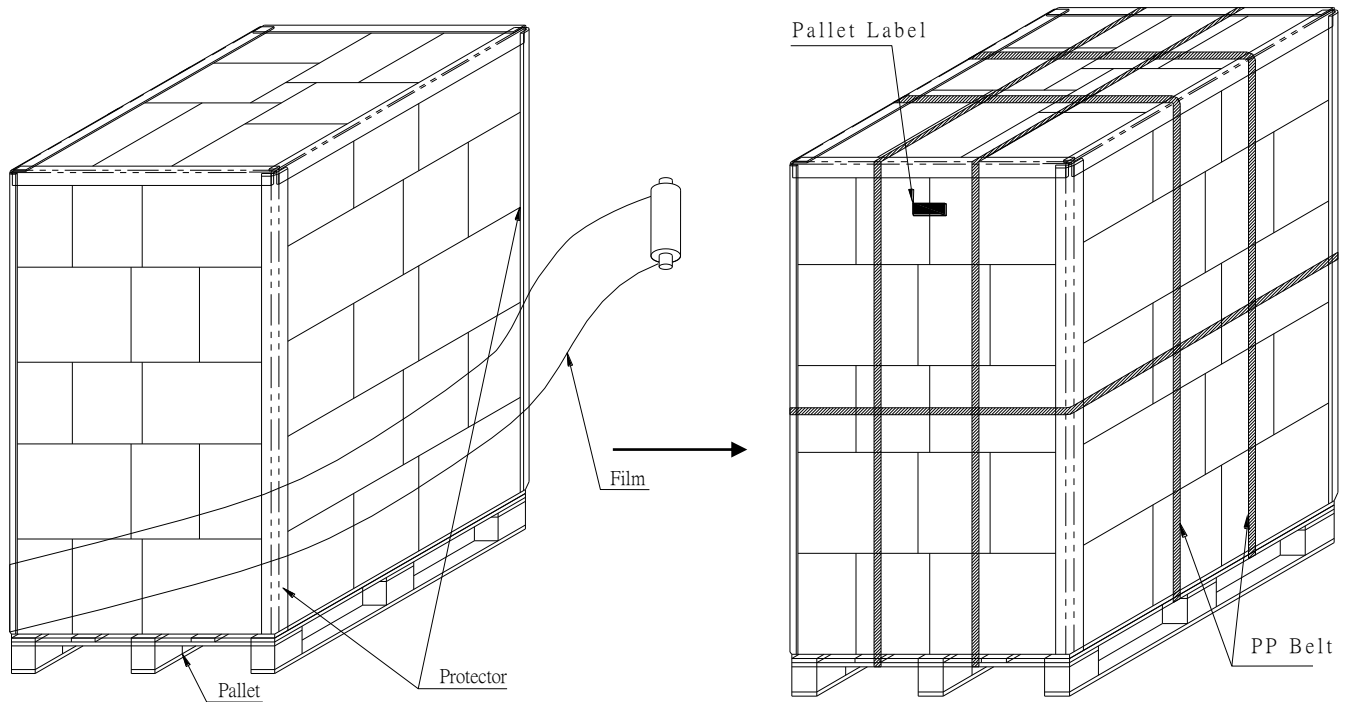

17(pcs)x40(BOX)=680pcs

	10.2" EPD BOX
N.W. :	1.56Kg
G.W. :	4.77Kg

Sea / Land / Air Transpo

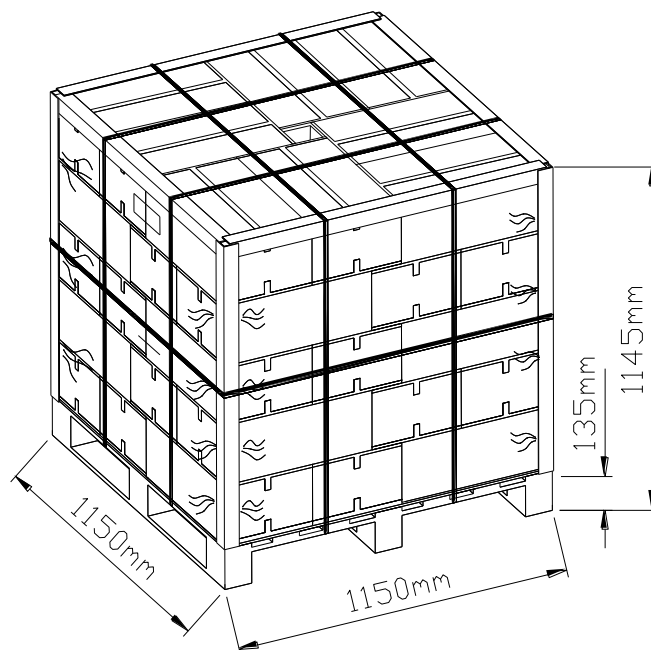

8 Precautions

- (1) The EPD Panel / Module is manufactured from fragile materials such as glass and plastic, and may be broken or cracked if dropped. Please handle with care. Do not apply force such as bending or twisting to the EPD panel during assembly.
- (2) It is recommended to assemble or install EPD panels in a clean working area. Dust and oil may cause electrical shorts or degrade / scratch / den the protection sheet film.
- (3) Do not apply pressure to the EPD panel in order to prevent damaging it.
- (4) Do not connect or disconnect the interface connector while the EPD panel is in operation.
- (5) Please support the bezel with your finger while connecting the interface cable such as the FPC.
- (6) Do not stack the EPD panels / Modules.
- (7) Do not press the FPC on the glass edge or Pull FPC up / down to 90°.
- (8) Do not touch the FPC lead connector.
- (9) Do not touch IC bonding area. It may scratch TFT lead or damage IC function.
- (10) Wear a Wrist Strap (Grounding connect) when handling and during assembly. Semiconductor devices are included in the EPD Panel / Module and they should be handled with care to prevent any electrostatic discharge (ESD). (An Ion Fan may be needed in assembly operation to reduce ESD risk.)
- (11) Keep the EPD Panel / Module in the specified environment and original packing boxes when storage in order to avoid scratching.
- (12) Do not disassemble or reassemble the EPD panel.
- (13) Use a soft dry cloth without chemicals for cleaning. Please don't press hard for cleaning because the surface of the protection sheet film is very soft and without hard coating. This behavior would make dent or scratch on protection sheet.
- (14) Please be mindful of moisture to avoid its penetration into the EPD panel, which may cause damage during operation.
- (15) It's low temperature operation product. Please be mindful the temperature different to make frost or dew on the surface of EPD panel. Moisture may penetrate into the EPD panel because of frost or dew on surface of EPD panel, and makes EPD panel damage.
- (16) High temperature, high humidity, sunlight or fluorescent light may degrade the EPD panel's performance. Please do not expose the unprotected EPD panel to high temperature, high humidity, sunlight, or fluorescent for long periods of time. Please store the EPD panel in controllable environment of warehouse and original package: Without sunlight, without condensation, a temperature range of 15°C to 35°C, and humidity from 30%RH to 60%RH.
- (17) The ink used for marking the Panel ID number is erased easily by solvent. Please avoid using solvent to clean the EPD panel.

- (18) The EPD is vacuum packed.
- (19) Before approved by PDI and customer, products and product specifications may be subject to change without notice. Confirm that you have received the latest product standards or specifications before final design, purchase or use.
- (20) PDI makes every attempt to ensure that its products are of high quality and reliability. However, contact PDI sales office before using the product in an application that demands especially high quality and reliability or where its failure or malfunction may directly threaten human life or cause risk of bodily injury, such as aerospace, aeronautics, nuclear power, combustion control, transportation, traffic, safety equipment or medical equipment for life support.
- (21) Design your application so that the product is used within the ranges guaranteed by PDI particularly for maximum rating, operating supply voltage range, heat radiation characteristics, installation conditions and other characteristics. PDI bears no responsibility for failure or damage when used beyond the guaranteed ranges. Even within the guaranteed ranges, consider normally foreseeable failure rates or failure modes in semiconductor devices and employ systemic measures such as fail safes, so that the equipment incorporating PDI product does not cause bodily injury, fire or other consequential damage due to operation of the PDI product.
- (22) This product is not designed to be radiation resistant.

9 Definition of Labels

Figure 9-1 Model Labels

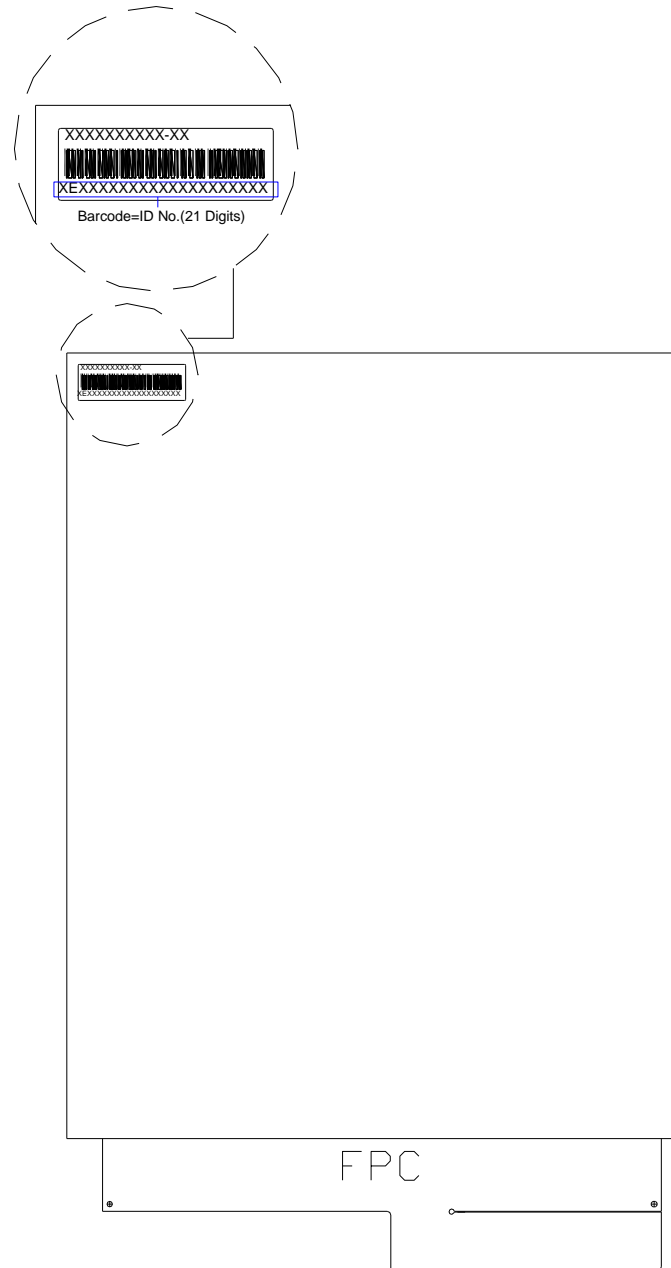

Figure 9-2 Definition of Model Labels

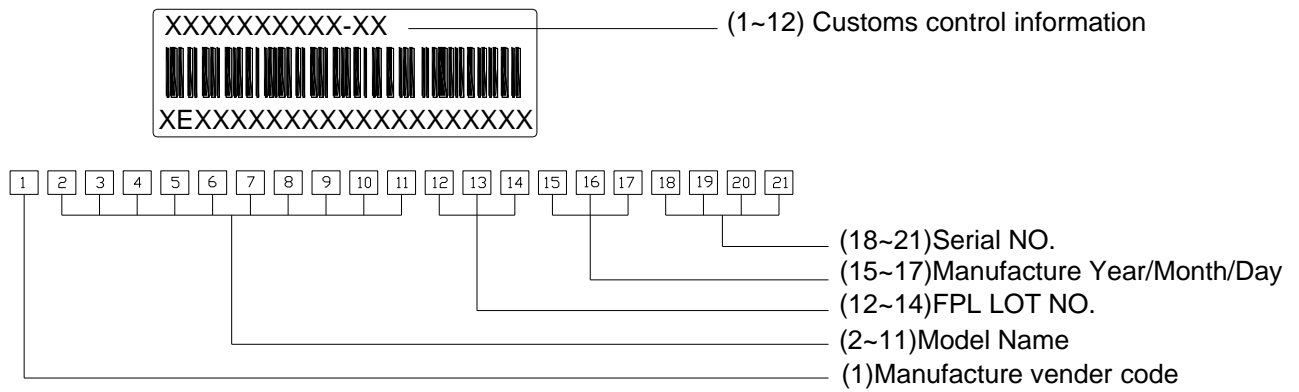
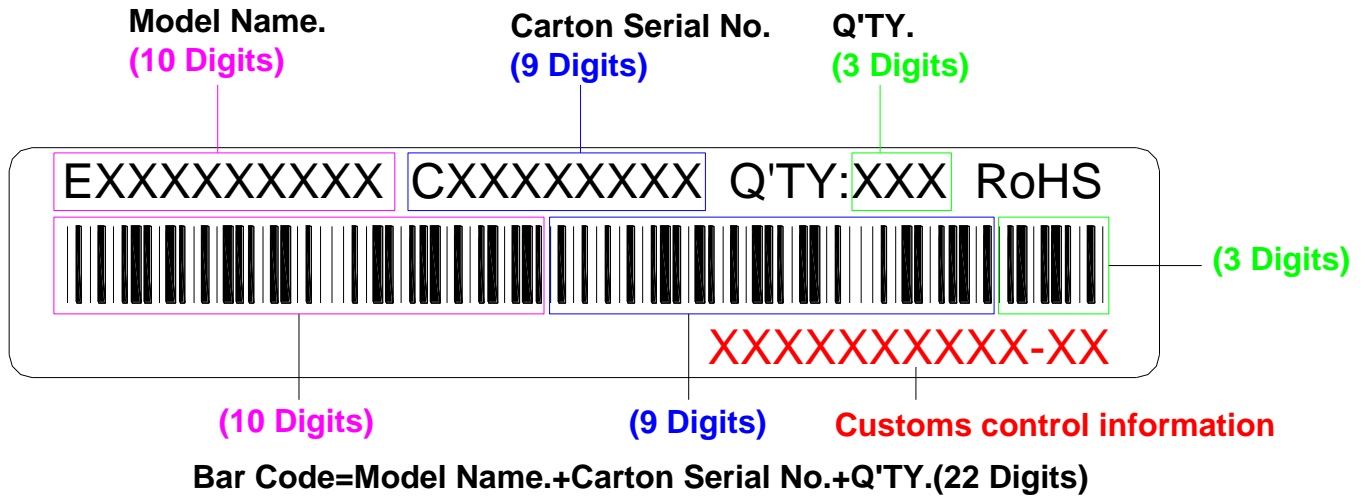

Figure 9-3 Carton Label



Carton Label

Figure 9-4 Pallet Label



Pallet Label