

# SPECIFICATION FOR APPROVAL

CUSTOMER : \_\_\_\_\_

PRODUCT TYPE : Oven-Controlled Crystal Oscillator (OCXO)

NOMINAL FREQ. : 19.44MHz

TXC P/N : OG19470001

REVISION : S3

CUSTOMER P/N : \_\_\_\_\_

PM / SALES : Oak Yu

DATE : 1-Mar-22

CUSTOMER CONFIRMATION : \_\_\_\_\_  
(Signature)

\_\_\_\_\_ (Date)

- (1) TXC requires one copy returned with signature and title of authorized individual that signifies acceptance of the attached specifications.
- (2) Orders received and accepted by TXC after return of signed copy of specification will be produced per these specifications.
- (3) Any changes to these specifications must be agreed upon by both parties and new revision of the Product Specification Sheet will be issued.
- (4) Any issuance of purchase order prior to consigning back the Approval page of "Specification Sheets" from customers will be regarded as the agreement on the contents of these specifications.

**RoHS Compliant**

(for glass crystal only : Pb used in sealing glass material is exempt from EU directive)

# SPECIFICATION FOR APPROVAL

PRODUCT TYPE : Oven-Controlled Crystal Oscillator (OCXO)

---

NOMINAL FREQ. : 19.44MHz

---

TXC P/N : OG19470001

---

REVISION : S3

---

PE/RD	QA	MFG
 Wan-Lin Hsien		
1-Mar-22		

**NOTE:**

- (1) The green product standard set by TXC is based upon the international standards. Related information is publicly described on the TXC's Website, and updated regularly. The document is compliant with the latest green product quality system directives at the time.
- (2) Revision "Sx" is for engineering samples only. PE/RD's approval required.
- (3) Revision "Ax" is production ready. PE, QA and MFG's approval required.

**RoHS Compliant**

(for glass crystal only : Pb used in sealing glass material is exempt from EU directive)

<u>Rev</u>	<u>Revise page</u>	<u>Revise contents</u>	<u>Date</u>	<u>Ref.No.</u>	<u>Reviser</u>
S1	N/A	Initial released	1-Jun-20	N/A	Joe Yen
S2	2	Revise the operating temperature range to -40 ~ 85°C	4-Feb-21	N/A	Wil Hsieh
	6	Revise the reel quantity to 500 pcs per reel		N/A	
S3	2	Item 29 Allan deviation: Change Typ. 7.0 to 2.0 Add Max. 7.0	1-Mar-22	N/A	S.Chang
		Add Note 1			
	3	Add Note 2			
	4	Add Note 3			
	7	Add Note 4			

**ELECTRICAL SPECIFICATIONS(Note 1)**

Item	Parameters		Measurement Condition	Electrical Specifications			
				MIN	TYP	MAX	UNITS
1	Nominal frequency				19.44		MHz
2	Supply voltage (Vcc)		±5%	3.135	3.3	3.465	V
3	Current consumption	During warm up	Ambient temperature at 25°C			750	mA
4		At steady state				200	mA
5	Warm-up time		Time needed for frequency to be within ±50 ppb reference to frequency after 1 hour, at 25°C.			3	minute
6	Initial frequency accuracy		At time of shipment, reference to nominal frequency, at 25°C±2°C	-500		500	ppb
7	Start up time					200	msec
8	Reflow shift		After 1 hour recovery at 25°C	-1		1	ppm
9	Operating temperature range			-40		85	°C
10	Frequency stability	vs. temperature	Within operating temperature range, reference to (Fmax+Fmin)/2	-20		20	ppb
11		vs. Vcc variation	Vcc variation ±5%, reference to frequency at Vcc=3.0V		±10		ppb
12		vs. load variation	Load variation ±5%, reference to frequency at load= 15pF		±10		ppb
13	Frequency slope (in still air)		Temperature ramping rate 0.5° C/minute max.	-1.5		1.5	ppb/°C
14	Output load				15		pF
15	Output waveform	Output type		LVCMOS			NA
16		High level (VOH)		2.97			V
17		Low level (VOL)				0.4	V
18		Duty cycle		45		55	%
19		Rise time				4	ns
20		Fall time				4	ns
21	phase noise	At 1Hz offset	Ambient temperature at 25°C		-77		dBc/Hz
22		At 10Hz offset			-109		dBc/Hz
23		At 100Hz offset			-132		dBc/Hz
24		At 1kHz offset			-147		dBc/Hz
25		At 10kHz offset			-155		dBc/Hz
26		At 100kHz offset			-158		dBc/Hz
27		At 1MHz offset			-159		dBc/Hz
28	Jitter		RMS, 12kHz ~ 5MHz		0.35		ps
29	Allan deviation	Tau=1.0s	Ambient temperature at 25°C		2.0	7.0	e-11
30	Aging	Daily	After 30 days of operation		±2		ppb
31		1st year				±800	ppb
32		10 years					±2

**SPECIFICATIONS NOTES**

Note 1 The frequency specifications apply after 48 hours of continuous operation after soldering and assembly based on nominal conditions.

**STRATUM 3E COMPLIANCE**

Item	Parameters		Measurement Condition	Electrical Specifications			
				MIN	TYP	MAX	UNITS
1	Holdover stability (in still air)	At constant temperature	After 30days of operation, reference to F(t=0), 24 hours			5	ppb
2	Free-run accuracy		Including all causes in 20 years, reference to nominal frequency.	-4.6		4.6	ppm
3	Wander Generation	MTIE	Compliant with GR-1244 Fig 5-5 & G.812 types II & III Fig. 1				
4		TDEV	Compliant with GR-1244 fig 5-4 & G.812 types II & III Fig. 2				

**ENVIRONMENTAL & MECHANICAL CONDITION (Note 2)**

Item	Description	Condition	Reference
1	Storage temperature range	-55°C to +125°C	N.A.
2	Temperature cycling	Test Na, 400 cycles, -40°C to +125°C	IEC 60068-2-14
3	Moisture sensitivity	Class 1	IPC/JEDEC J-STD-020
4	Solderability	Method 2 preconditioning 150°C, 16 hours	JESD 22-B102D
5	Humidity	85°C/85%R.H., 1000 hours	EIA/JEDEC22-A101
6	Mechanical shock	Test Ea; 1500g, 0.5ms, 18 shocks total	IEC 60068-2-27
7	Acceleration steady state	Test Ga, 5000g, 10s (at peak acceleration), Y-axis onl	IEC 60068-2-7
8	Vibration	Test Fc: 20g, 60Hz to 2000Hz 12 hours total	IEC 60068-2-6
9	RoHS compliant	Parts are fully compliant with the European Union directive 2002/95/EC on the restriction of the use of certain hazardous substances in electrical and electronic equipment.	EU directive 2002/95/EC

Note 2 The units related to above tests are pre-conditioned based on J-STD-020, moisture level 2 and three times reflow

■ TESTING CIRCUIT

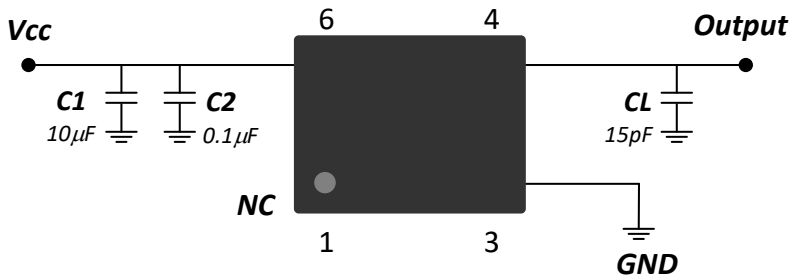

External components:

Name	Function
C1	AC Noise Bypass for Vcc
C2	AC Noise Bypass for Vcc
CL	Load Capacitance

Note: Bypass capacitor should be placed.

■ DIMENSION & PAD CONNECTIONS

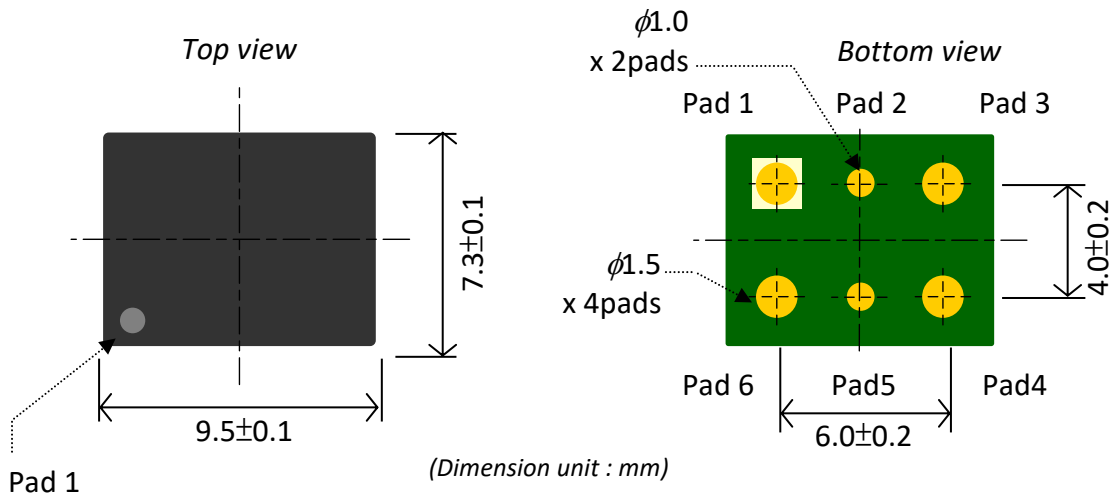

Pin No.	Function
1	NC
2	DNC
3	GND
4	Output
5	DNC
6	Vcc

Note 3 DNC represents "do not connect", please do not connect these pins to any terminal functions.

■ MARKING

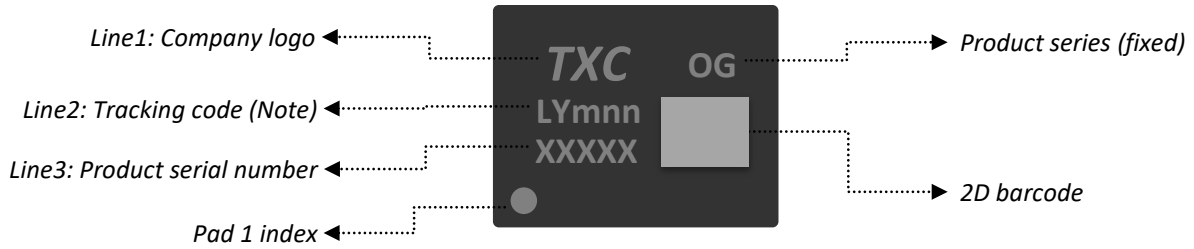

(Note) Tracking Code = Lot (L) + Year (Y) + Month (m) + Lot Serial Number (nn)

Year

2017	2018	2019	2020	2021
A	B	C	D	E
2022	2023	2024	2025	2026
F	G	H	J	K
2027	2028	2029	2030	2031
M	N	P	Q	R
2032	2033	2034	2035	2036
S	T	U	V	W

Month

JAN	FEB	MAR	APR	MAY	JUN
a	b	c	d	e	f
JUL	AUG	SEP	OCT	NOV	DEC
g	h	j	k	m	n

■ RECOMMENDED PAD LAYOUT

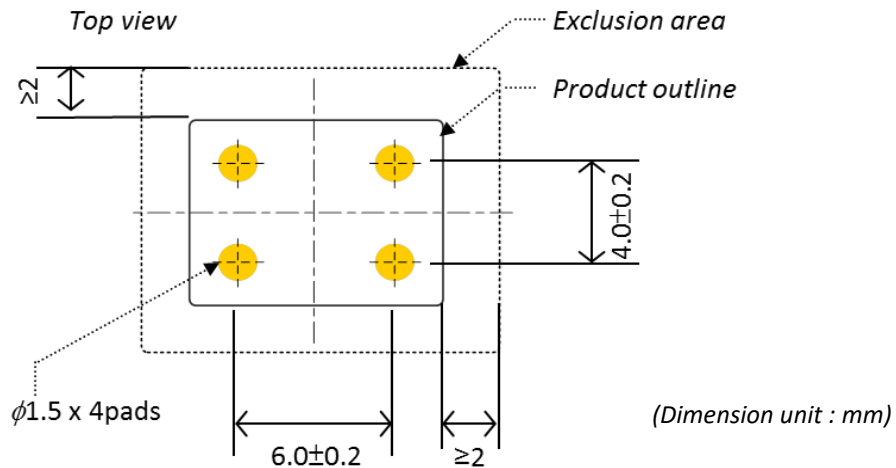

- (1) Recommended exclusion area in any copper plane to isolate the OCXO from the underlying ground or power planes to reduce thermal loss.
- (2) To further minimize the thermal loss, it is also recommended that the trace connecting to the pads should not connect to any layer inside the exclusion area.
- (3) For the same reason, it is recommended to preserve the exclusion area larger than the product size of 2mm in both of length and width.

■ **PACKING**

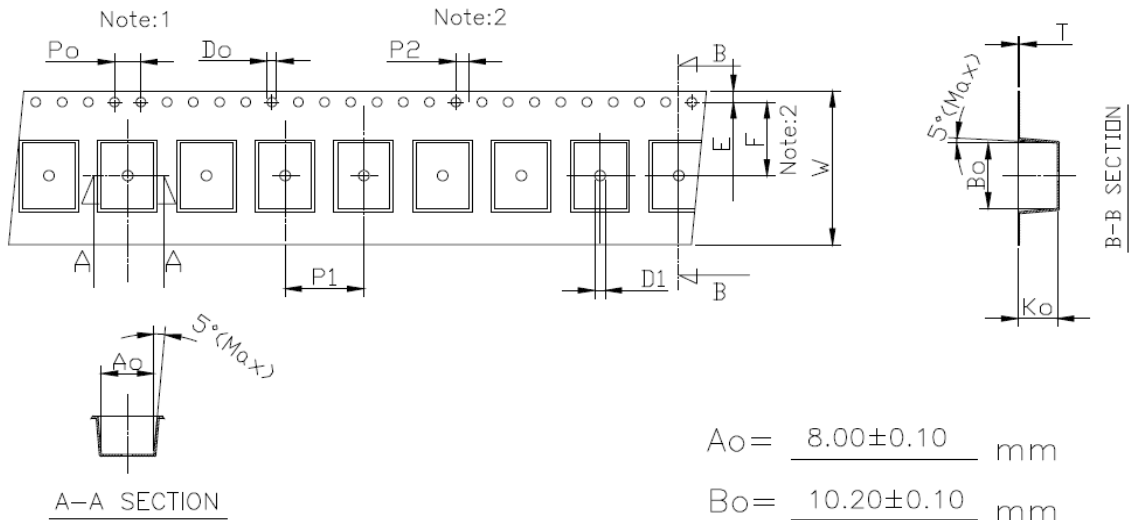

$A_0 = \underline{8.00 \pm 0.10}$  mm  
 $B_0 = \underline{10.20 \pm 0.10}$  mm  
 $K_0 = \underline{6.00 \pm 0.10}$  mm

Symbol	Spec.
Po	4.0±0.10
P1	12.0±0.10
P2	2.0±0.10
Do	1.50 <sup>+0.1</sup> / <sub>-0</sub>
D1	1.50(MIN)
E	1.75±0.10
F	11.50±0.10
10Po	40.0±0.10
W	24.0 <sup>+0.3</sup> / <sub>-0.1</sub>
T	0.40±0.05

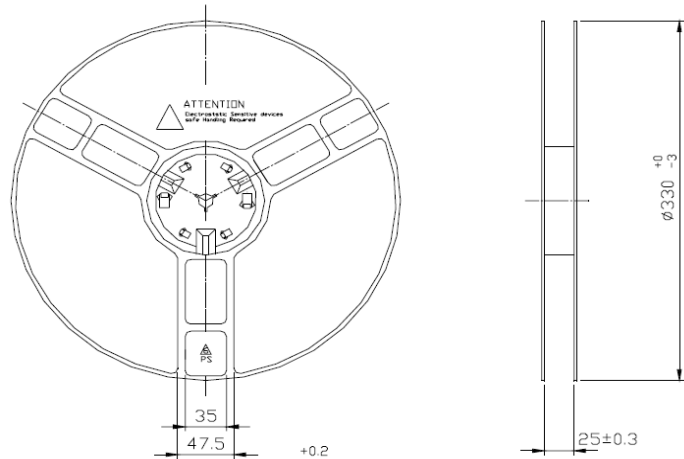

Notice:

1. 10 Sprocket hole pitch cumulative tolerance is ±0.1mm
2. Pocket position relative to sprocket hole measured as true position of pocket not pocket hole.
3. A<sub>0</sub> & B<sub>0</sub> measured on a place 0.3mm above the bottom of the pocket to top surface of the carrier.
4. K<sub>0</sub> measured from a plane on the inside bottom of the pocket to the top surface of the carrier.
5. Carrier camber shall be not than 1mm per 100mm through a length of 250mm.

Standard Reel Quantity is 500 pcs per reel



■ **RECOMMENDED REFLOW SOLDERING PROFILE**

Pb-free reflow soldering profile

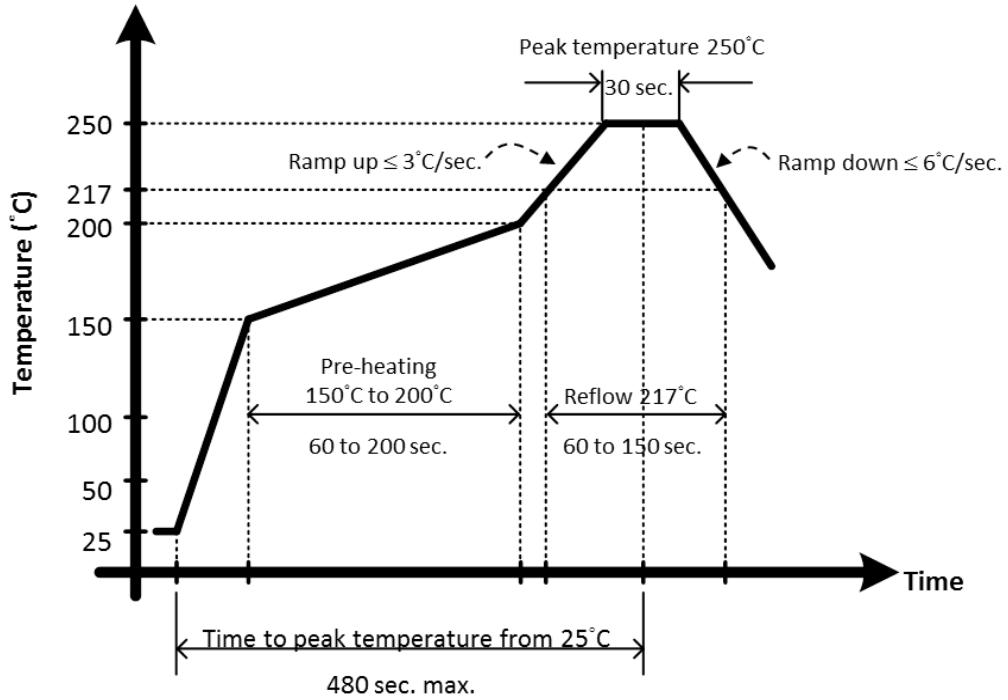

Note 4 In case of the manual soldering, please do not apply the excess heat source to the plastic cover of device. The plastic cover may be damaged when the excess temperature is over 270°C within a period of time.