

FEMALE RIGHT ANGLE PLUG SOLDER TYPE

R222.151.000

CABLE .047

Series : SMP

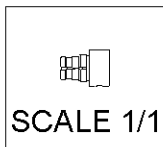
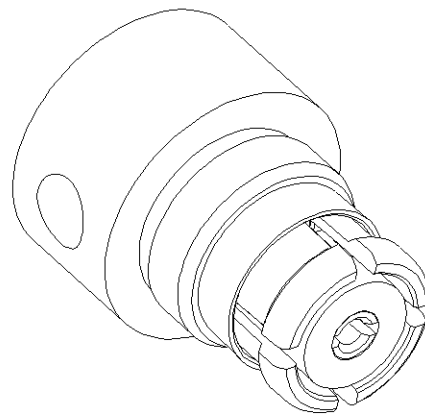
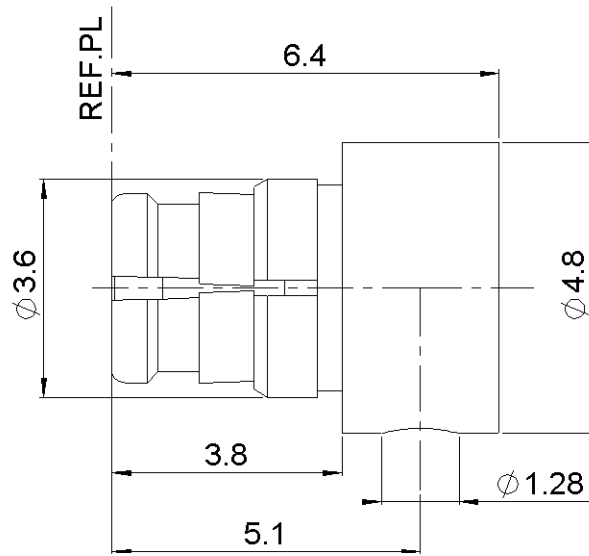

All dimensions are in mm.

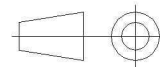

COMPONENTS	MATERIALS	PLATING (µm)
BODY	BERYLLIUM COPPER	GOLD OVER NICKEL
CENTER CONTACT	BERYLLIUM COPPER	GOLD OVER NICKEL
OUTER CONTACT	-	-
INSULATOR	PTFE	-
GASKET	-	-
OTHERS PARTS	BERYLLIUM COPPER; BRASS	GOLD OVER NICKEL
-	-	-
-	-	-

Issue : 1241 D

In the effort to improve our products, we reserve the right to make changes judged to be necessary.



FEMALE RIGHT ANGLE PLUG SOLDER TYPE

R222.151.000

CABLE .047

Series : SMP

PACKAGING

Standard	Unit	Other
100	'W' option	Contact us

SPECIFICATION

ELECTRICAL CHARACTERISTICS

Impedance		50 Ω
Frequency		0-26.5 GHz
VSWR	1.35 +	0.0000 x F(GHz) Maxi
Insertion loss		0.12 √F(GHz) dB Maxi
RF leakage	- (* - F(GHz)) dB Maxi
Voltage rating		270 Veff Maxi
Dielectric withstanding voltage		400 Veff mini
Insulation resistance		5000 MΩ mini

CABLE ASSEMBLY

Stripping	a	b	c	d	e	f
mm	1.30	0.00	0.00	0.00	0.00	0.00

Assembly instruction :

Recommended cable(s)
UT47 M17/151-00001

Characteristics indicated on this data sheet are those that can be achieved with the highest performance cable. Intrinsic limitations of the cable may diminish the performance of the assembly

Cable retention

- pull off **45** N mini
- torque **NA** N.cm

MECHANICAL CHARACTERISTICS

Center contact retention		
Axial force – Mating end	6.7	N mini
Axial force – Opposite end	6.7	N mini
Torque	NA	N.cm mini

TOOLING

Part Number	Description	Hexagon
R282.740.030	SOLDERING MOUNTING	
R282.743.120	POSITIONER FOR SOLDERING SMP	

Recommended torque		
Mating	NA	N.cm
Panel nut	NA	N.cm
Clamp nut	NA	N.cm
A/F clamp nut	0.0000	mm

Mating life	100	Cycles mini
Weight	0.4850	g

OTHER CHARACTERISTICS

*RF leakage : -80dB DC-3GHz
-65dB :3-26.5GHz
Compliant with MIL.STD.348

ENVIRONMENTAL

Operating temperature	-65/+165	° C
Hermetic seal	NA	Atm.cm3/s
Panel leakage	NA	

Issue : 1241 D

In the effort to improve our products, we reserve the right to make changes judged to be necessary.



FEMALE RIGHT ANGLE PLUG SOLDER TYPE

R222.151.000

CABLE .047

Series : SMP

COMPONENT

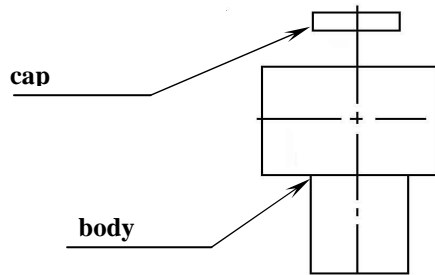

STRIPPING DIMENSIONS

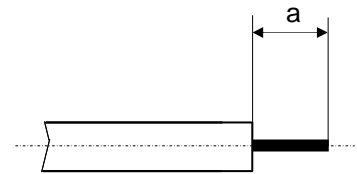

We recommend a thermal preconditioning cable

1

Strip the cable .
Clean the cable .
The iron temperature shall not exceed 250°C max

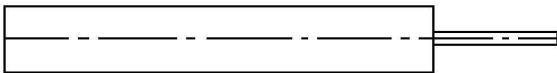

2

Slide the assembly in the soldering jig and tighten.
Slide cable into connector until it bottoms against the body and tighten.
Solder the body onto the cable .

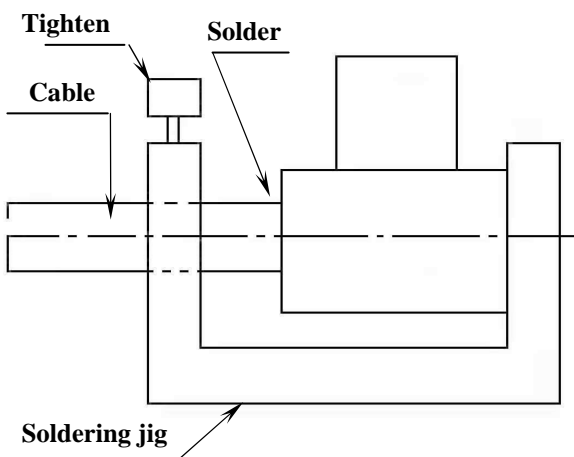

3

After cooling remove the cable assembly from the jig .
Slide the body into the positioner until its bottoms against the positioner .
Slide cable assembly into the jig and tighten.
Solder the contact.
After cooling remove cable assembly from the jig.

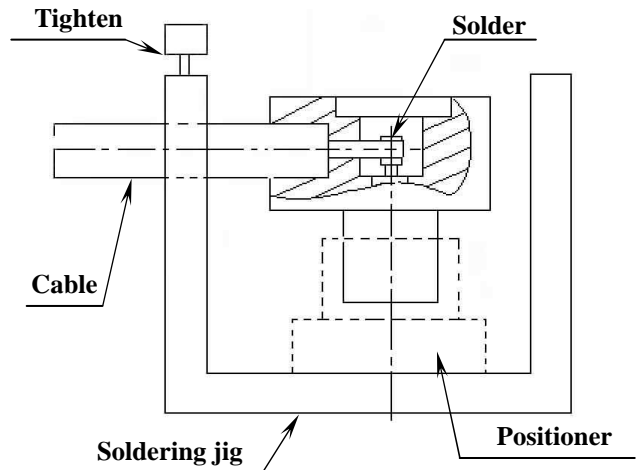

4

Place cable assembly into a dia $D = 3.8 \pm 0.1$ and thickness $E = 4 \pm 0.1$.
Place cable assembly below a flat pressing tool .
Press-fit the cap until it bottoms against the body .
(direction F)

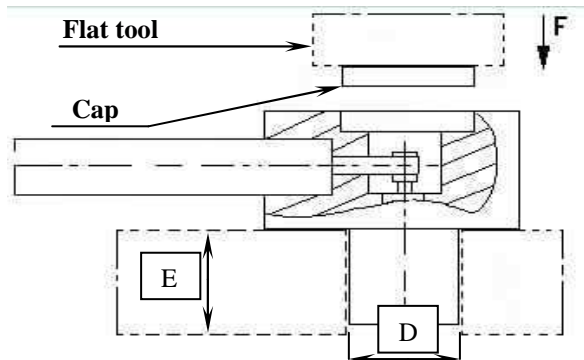

Issue : 1241 D

In the effort to improve our products, we reserve the right to make changes judged to be necessary.

