

TABELA 1
CHART 1

MOLEX PN	WOODHEAD PN	L(mm)	TYP
1200310015	4R3F30E02C3003	300	3 POLOWY
1200310053	4R3F30E02M0203	2000	3 POLOWY
1200310034	4R4F30E02C2003	200	4 POLOWY
1200310049	4R4F30E02C3003	300	4 POLOWY
1200310058	4R4F30E02M0103	1000	4 POLOWY
1200310028	4R5F30E02C3003	300	5 POLOWY
1200310111	4R4F30E02M010	1000	4 POLOWY
1200905002	4R4F30E03M0203	2000	4 POLOWY
1200908011	4R4F30E02C300	300	4 POLOWY

Tablica tolerancji dlugosci
Table of length tolerances

Powyzej Over	Do-wlacznice Up to and including	Tolerancja (+) Tolerance
0	305	+19
305	915	+45
915	1830	+56
1830	3660	+89
3660	7320	+165
7320	14640	+317
14640	30500	+610
30500	>	+2% dlugosci of length

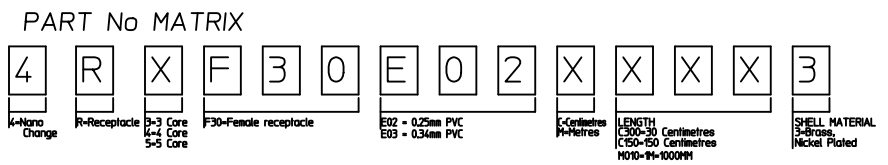

WIDOK OD STRONY CZOLA
FACE VIEW

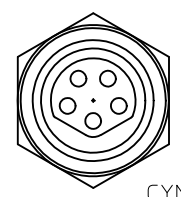

CYNOWAC
TINNED

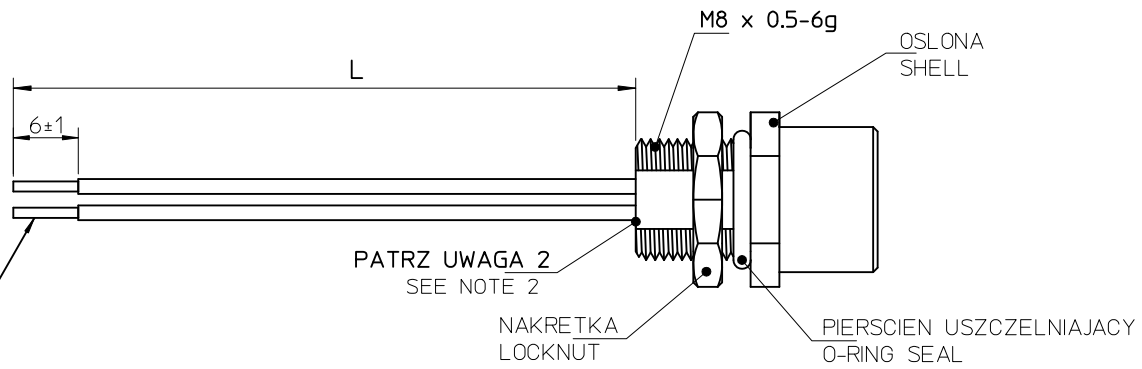

- UWAGI:
- DLUGOSC CIECIA I SPECYFIKACJE NABIJANIA WEDLUG LISTY CIECIA.
 - PO OSADZENIU TERMINALI ZALAC KLEJEM.

- NOTES:
- FOR CUTTING LENGTH AND CRIMPING SPECIFICATION SEE CUTTING LIST.
 - AFTER ASSEMBLED TERMINALS THE CONNECTOR MUST BE FLOOD BY GLUE.

ORIGINAL RELEASE EC NO: WEU2009-0439 DRWN: MWOLSZCZAK 2009/06/04 CHKD: APPR: MDYSZEWSKA 2011/12/08	QUALITY SYMBOLS ▽=0 ◻=0	GENERAL TOLERANCES (UNLESS SPECIFIED)		DIMENSION STYLE MM ONLY		SCALE ---	DESIGN UNITS METRIC	FIRST ANGLE PROJECTION		
		mm	INCH	DRAWN BY MWOLSZCZAK	DATE 2008/05/10	TITLE NC-XP-FE-REC -XXXM-M8-THD.				
		4 PLACES ± ---	± ---	CHECKED BY MDABROWSKA	DATE 2008/05/10	APPROVED BY MDYSZEWSKA 2011/12/08				
		3 PLACES ± ---	± ---	MATERIAL NO. SEE DRAWING		DOCUMENT NO. 4RXF30XXXXXXX3		SHEET NO. 1 OF 1		
ANGULAR ± ---°		DRAFT WHERE APPLICABLE MUST REMAIN WITHIN DIMENSIONS		THIS DRAWING CONTAINS INFORMATION THAT IS PROPRIETARY TO MOLEX INCORPORATED AND SHOULD NOT BE USED WITHOUT WRITTEN PERMISSION						

FEMALE FACE VIEW

3 POLE 4 POLE 5 POLE

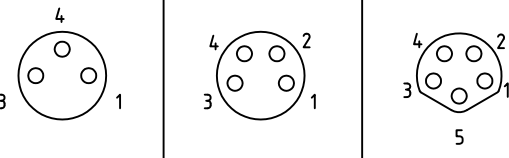

Pin No.	Wire	Pin No.	Wire	Pin No.	Wire
1	Brown	1	Brown	1	Brown
2	-	2	White	2	White
3	Blue	3	Blue	3	Blue
4	Black	4	Black	4	Black
				5	Grey

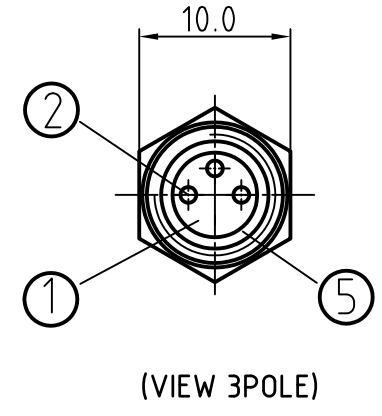
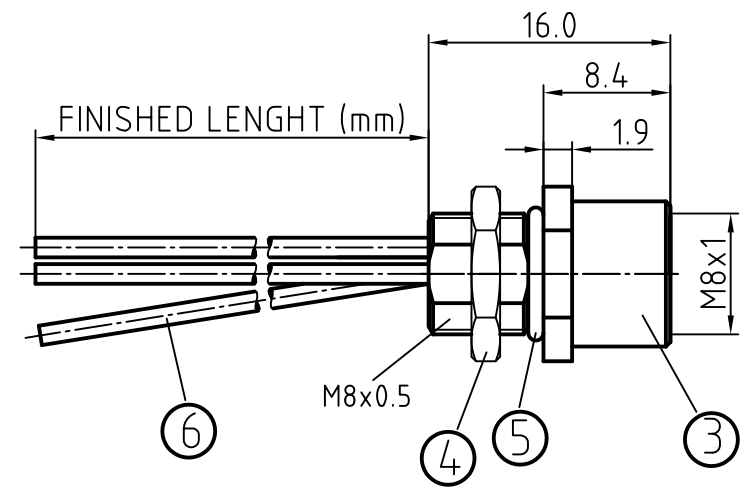
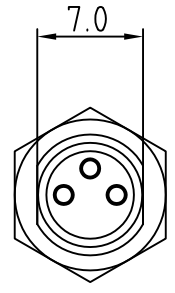

PANEL CUT OUT

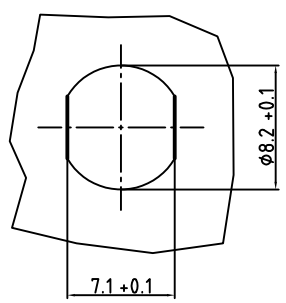

POLE	MATERIAL NUMBER	ENGINEERING NUMBER	FINISHED LENGHT (MM)
3	1200310015	4R3F30E02C3003	300±25
4	1200310034	4R4F30E02C2003	200±25
5	1200310028	4R5F30E02C3003	300±25

CONNECTOR SPECIFICATION:	
VOLTAGE RATING	3-4POL:60V/AC 75V/DC 5POL:30V/AC 36V/DC
AMPERAGE RATING	3 AMPS
PROTECTION	IP67
OPERATING TEMPERATURE	-25°C TO +90°C

ITEM	COMPONENT	MATERIAL	FINISH
1	INSERT	POLYURETHANE (PUR)	BLACK
2	CONTACT SOCKET	COPPER ALLOY	GOLD OVER NICKEL
3	SHELL	BRASS	NICKEL PLATED
4	LOCKNUT	BRASS	NICKEL PLATED
5	O-RING	VITON	
6	COPPER STRANDING AWG24/0.25mm ²	JACKET: PVC	

DESCRIPTION EC NO: WEU2010-0338 DRWN: REISSNER 2010/02/18 CHKD: RE APPR: FPACHER 2010/02/24	QUALITY SYMBOLS	GENERAL TOLERANCES (UNLESS SPECIFIED) mm INCH 4 PLACES ±--- ±--- 3 PLACES ±--- ±--- 2 PLACES ±--- ±--- 1 PLACE ±0.1 ±--- ANGULAR ± --- °	DIMENSION STYLE	SCALE	DESIGN UNITS	THIRD ANGLE PROJECTION	
			MM ONLY	2:1	METRIC		
			DRAWN BY	DATE	NC-XP-FE-REC-XM AWG24-PVC FRONT MOUNT		
			REISSNER	2010/02/18	MOLEX INCORPORATED		
			CHECKED BY	DATE			
			FP	2010/02/18			
			APPROVED BY	DATE			
			FPACHER	2010/02/19			
			MATERIAL NO.	DOCUMENT NO.	SHEET NO.		
				SD-120090-028	1 OF 1		
			SIZE	THIS DRAWING CONTAINS INFORMATION THAT IS PROPRIETARY TO MOLEX INCORPORATED AND SHOULD NOT BE USED WITHOUT WRITTEN PERMISSION			
			A3				