

DRAWING MADE IN THIRD ANGLE PROJECTION  
 THIS DRAWING IS UNPUBLISHED. RELEASED FOR PUBLICATION  
 © COPYRIGHT 19 BY AMP INCORPORATED. ALL INTERNATIONAL RIGHTS RESERVED.

LOC	DIST	P	F	ZONE	LTR	DESCRIPTION	DATE	APPO
DF	XO					RELEASED PER NPR 89-0192	5/12/89	KH/RH
						REVISED PER DF2079	7/24/89	RCH
						REVISED PER DF2563	11/21/89	RCH
						REVISED PER DF2990	2-28-90	PY
						REVISED PER DF3222	4-12-90	PY
						REVISED PER DF3583	7-24-90	PY
						REV PER 0600-0177-93 JB		

- FOR USE WITH RG-142/U CABLE
- BRAID CRIMP; USE MILITARY TOOL M22520/5-01, WITH DIE SET M22520/5-11, CAVITY A OR EQUIVALENT
- CENTER CONTACT CRIMP; USE MILITARY TOOL M22520/5-01, WITH DIE SET M22520/5-11, CAVITY B OR EQUIVALENT
- SEE APPLICATION SPEC. 114-9017.
- PARTS PACKAGED UNASSEMBLED.

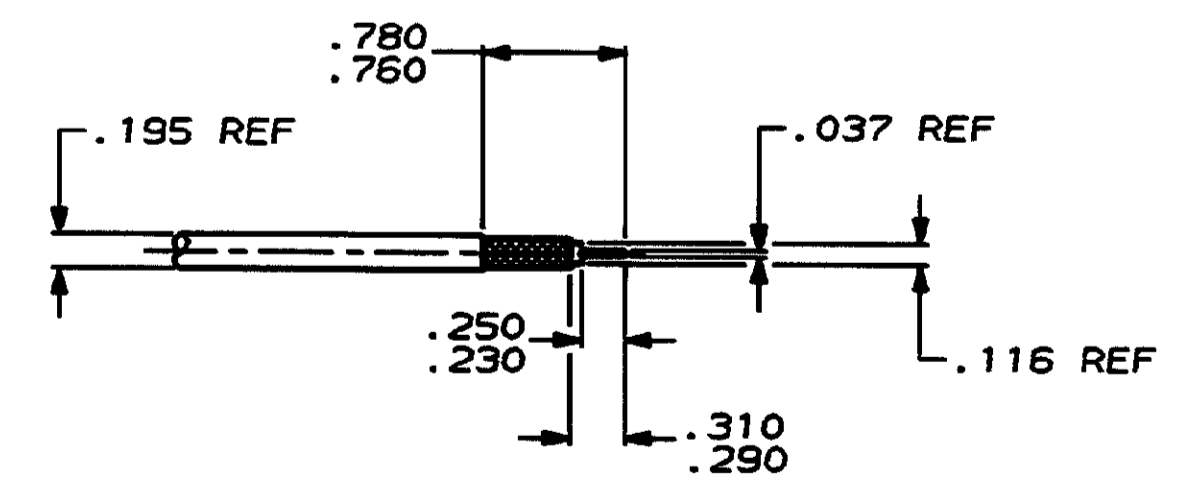
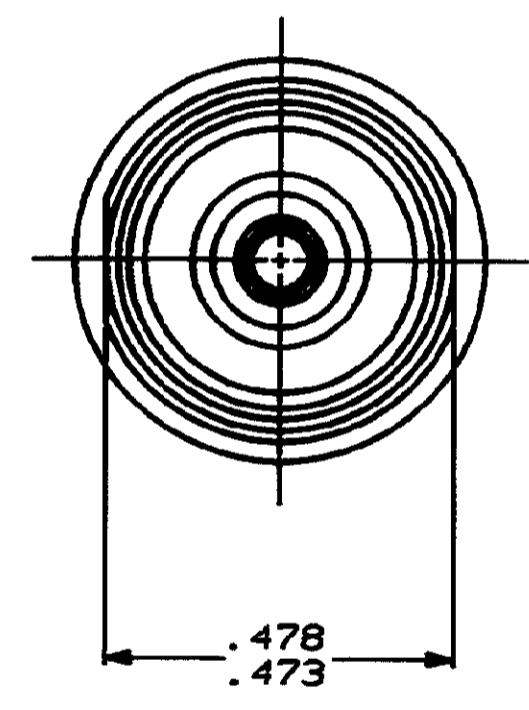
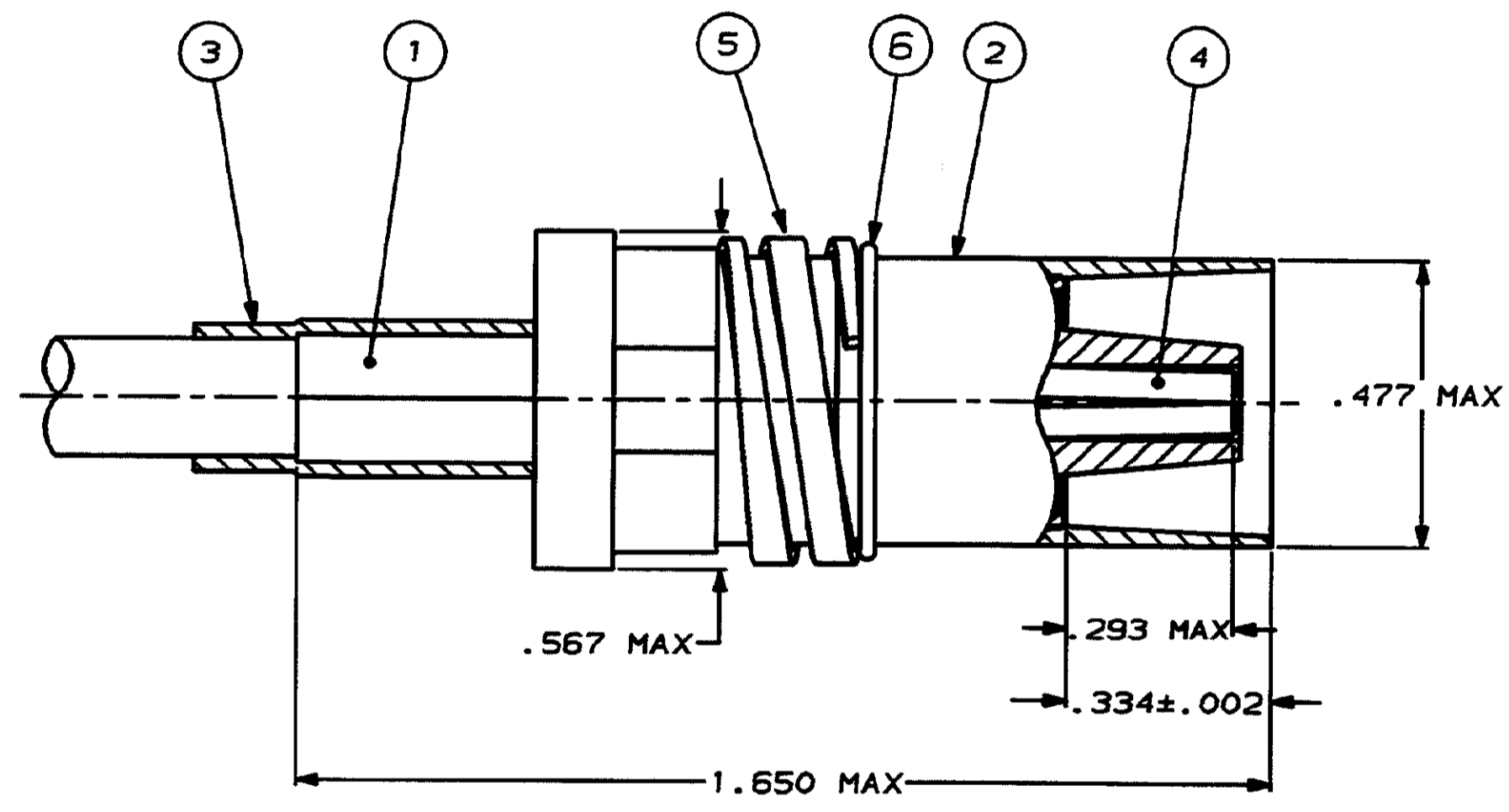

RECOMMENDED STRIP LENGTH  
SCALE 1:1

QTY	PART NO	DESCRIPTION	ITEM NO
1	985184-1	RING, RETAINING	6
1	446921-2	SPRING	5
1	446551-1	CONTACT ASSEMBLY	4
1	228143-2	HEAT SHRINK TUBING	3
1	446550-1	SOCKET ASSEMBLY	2
1	446556-3	FERRULE	1

DO NOT SCALE PRINT. UNLESS SPECIFIED DIMENSIONS IN INCHES TOLERANCES ON:		DR 5/11/89		AMP   AMP INCORPORATED Harrisburg, Pa. 17105	
2 PLC DEC ± -		CFK 5/12/89			
3 PLC DEC ± .005		APPD 5/12/89		NAME	
ANGLES ± -		R. HOSLER			
MATERIAL		APPD 5/12/89		COAXIAL CONTACT, SOCKET, SIZE 1, MODIFIED	
-		R. HOSLER			
FINISH		PRODUCT SPEC		SIZE	
-		APPLICATION SPEC		FSCN NO	
		-		C 00779	
WEIGHT		-		DRAWING NO	
		SCALE 4:1		446549-1	
				SHEET 1 OF 1	

CUSTOMER DRAWING