

RCX

480VAC Three Phase Transient Voltage Filters



- 480 Volt Ratings
- Wye Configuration with Center Tap
- Three Phase (3Ø) Applications
- Varistor Option
- Single Package
- Stranded Wire Leads

Operation

Transient Voltage Filters

R-C networks (Resistance-Capacitance) are applied to circuits where transient electrical voltage spikes can cause a malfunction or damage in solid state controls or control systems (PLCs, CNCs, NCs, Solid State Counters, etc.). The RCX is typically applied in parallel with three phase inductive loads (motors) to absorb the transients generated when the load is disconnected from the line. It also absorbs electrical noise while the load is operating. The Varistor option provides additional protection by clamping the transients at a specific voltage level (Max. Clamping Voltage).

Specifications

Electrical

Input Voltage:

Up to 480VAC, 3Ø, 50/60Hz.

Capacitance:

0.47 microfarads, ±10%

Resistance:

220 ohms, ±5%, 7 watts

Varistors:

Max. Allowable AC Voltage: 625VAC

Max. Clamping Voltage: 1650V @ 50A

Energy: 40 joules

Bleeding Resistor:

1 megohms, 1/2 watt

Power Consumption:

37 watts @ 600VAC

Physical

Mounting: Surface

Termination:

#16 Stranded Wire Leads

Packaging: Dust Cover

Weight: 12 Oz.

Ambient Temperatures

Operating: -40°C to 85°C

Storage: -40°C to 85°C

Ordering Information

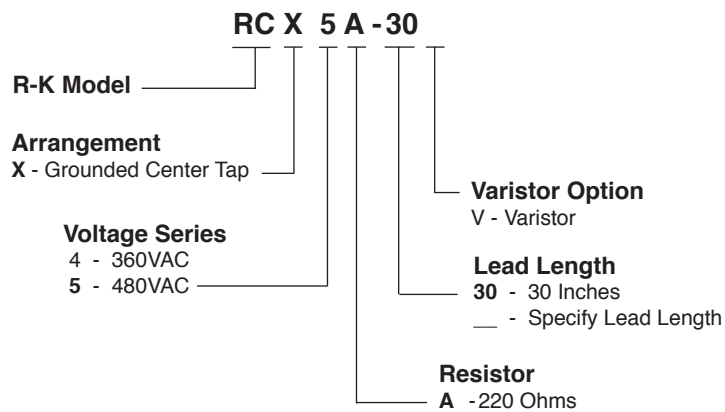

DIN Rail Bracket #DRB-4

Dimensions

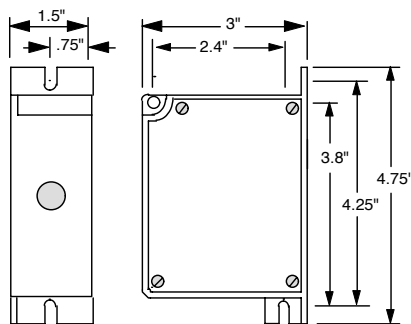

Connections

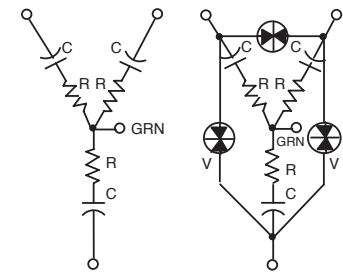

RCY6 _ _

RCY6 _ _ V

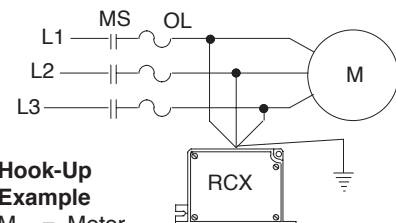

Hook-Up Example

M = Motor

MS = Motor Starter

OL = Overloads