

# Model 102

# STA<sup>®</sup> Pull DC Tubular Solenoid

Size: 1" OD X 1-1/8" L

ALL PRODUCTS ARE RoHS COMPLIANT

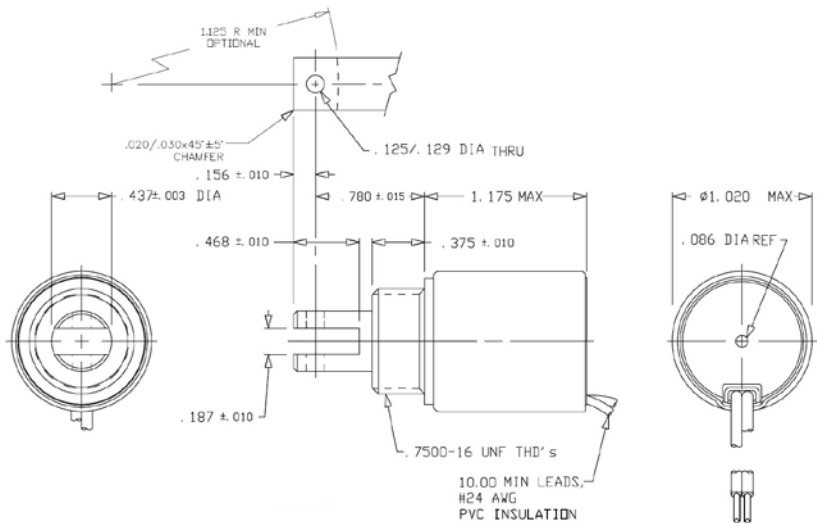

Solenoid shown energized with plunger fully seated  
 Supplied with hex nut shipped loose  
 Spring kits available (consult factory)

Part No.	Duty Cycle	Voltage	Resistance (Ω) ± 5%	Max On Time	Power (W)	Current (A)
152099-226	Continuous	6 VDC	3.85	∞	9.4	1.56
152099-227	Intermittent	12 VDC	5.32	24 secs	27.1	2.26
152099-228	Continuous	9 VDC	8.83	∞	9.2	1.02
152099-230	Continuous	12 VDC	22.78	∞	6.3	0.53
152099-230	Intermittent	24 VDC	22.78	24 Secs	25.3	1.05
152099-233	Continuous	24 VDC	93.08	∞	6.2	0.26

Continuous Duty = 100% "On" Time  
 Intermittent Duty = 25% "On" Time  
 When ordering please refer to Part No. as listed above  
 Please consult factory for custom configurations and other pole face angles

Stroke (in.)	Typical Pull Force (oz.)								Holding Force (oz.)
	0.060	0.125	0.250	0.375	0.500	0.625	0.750	1.000	
Continuous Duty	31.0	18.0	7.4	3.7	N/A	N/A	N/A	N/A	78.4
Intermittent Duty	77.4	53.7	25.3	11.1	6.3	N/A	N/A	N/A	N/A

### Additional Specifications:

Dielectric Strength: 1000 VRMS  
 Recommended Heat Sink: Maximum watts dissipated by solenoid are based on an unrestricted flow of air at 20°C, with solenoid mounted to the equivalent of an aluminum plate measuring 4" square by 1/8" thick.  
 Total Unit Weight: 3.8 oz. / 110 g  
 Plunger Weight: 1.0 oz. / 28.3 g

