

THIS DRAWING IS UNPUBLISHED.

RELEASED FOR PUBLICATION

© COPYRIGHT - By -

ALL RIGHTS RESERVED.

LOC	DIST	REVISIONS					
AF	50	P	LTR	DESCRIPTION	DATE	DWN	APVD
			L4	REVISED PER ECO-15-011479	06AUG15	JR	MD

6 OBSOLETE PARTS: OBSOLETE CIS STREAMLINING PER D.RENAUD/D.SINISI

7 CUSTOMER SPECIAL PACKAGING AND LABELING

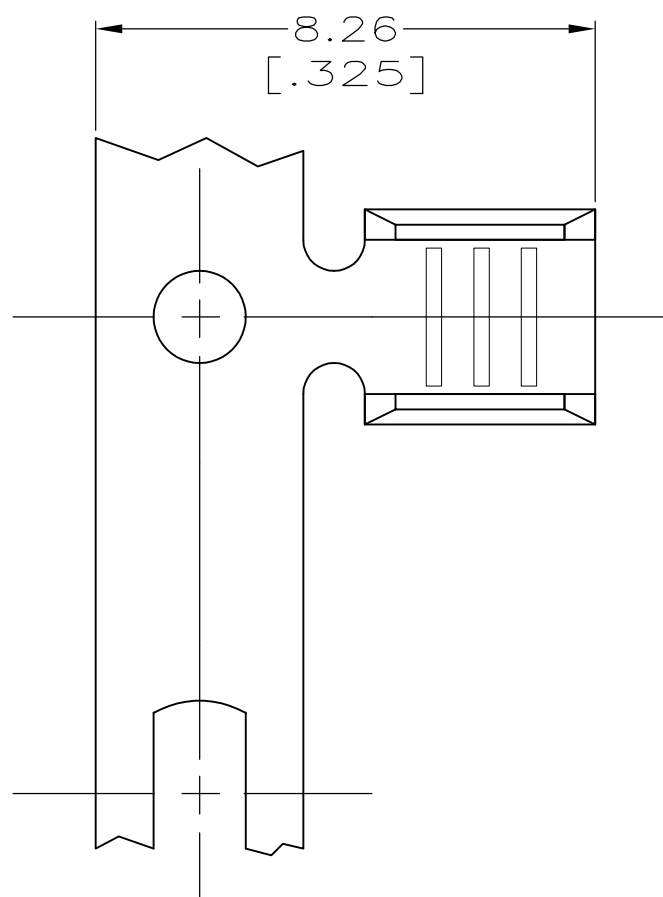

1 PRODUCT PROVIDED IN STRIP FORM ON REELS, BREAKS MAY BE PRESENT.

3 CRIMP WIDTH, .110 F TYPE
CRIMP HEIGHT (±.002) = (TOTAL CMA + 11,300) / 176,700

4 PRELIMINARY - NOT FOR PRODUCTION.

5 WIRE RANGE FOR NEW APPLICATIONS: 1500-5000 CMA
(WIRE RANGE APPROVED FOR APPLICATIONS IMPLEMENTED PRIOR TO 2005: 1970-4940 CMA).

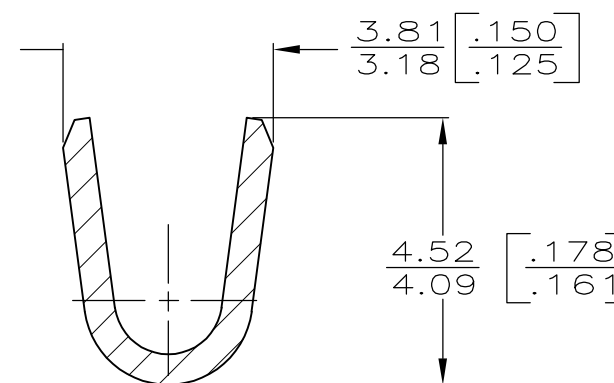

SECTION A-A
SCALE 10:1

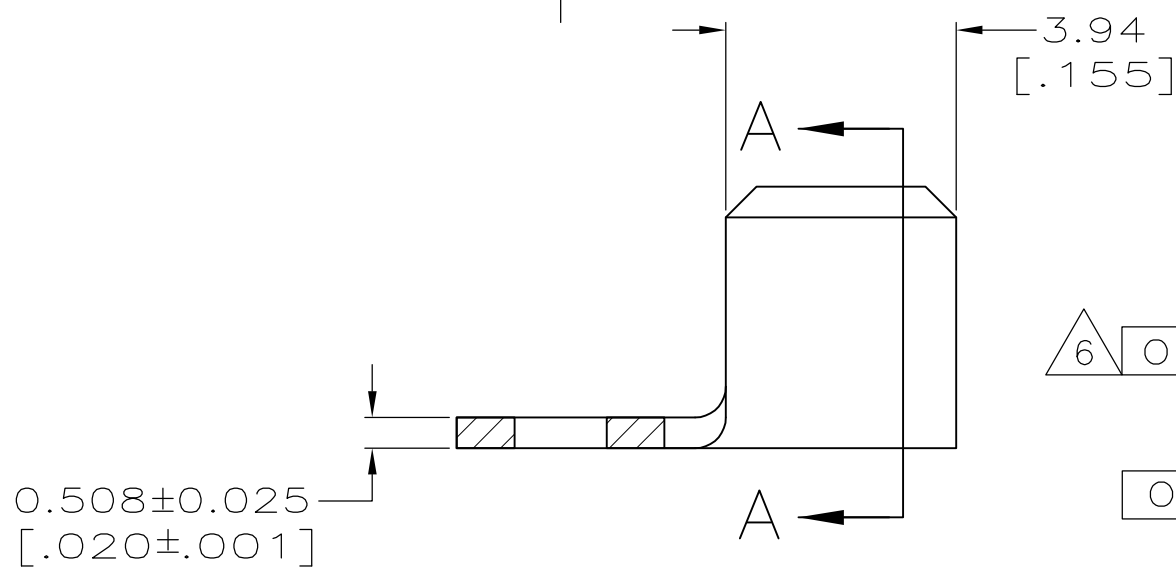

7	BRASS	TIN	REVERSE	-	63130-9
	STEEL	NICKEL			4 63130-8
6	COPPER-NICKEL	NONE	-	-	4 63130-7
	PHOS BRONZE	TIN			5 63130-4
OBSOLETE	BRASS	NONE	STANDARD	-	63130-3
					3 63130-2
					63130-1
	MATERIAL	FINISH	REELING	WIRE RANGE	PART NUMBER

THIS DRAWING IS A CONTROLLED DOCUMENT.		DWN 17/JAN/96 PHILLIP M FORTNEY	STE TE Connectivity		
DIMENSIONS: INCHES		CHK 17/JAN/96 JEFF R RUTH			
TOLERANCES UNLESS OTHERWISE SPECIFIED:		APVD 17/JAN/96 DENNIS SCHWENK	NAME -		
0 PLC ± -		PRODUCT SPEC	-		
1 PLC ± -			SPLICE		
2 PLC ± 0.25 [.010]		APPLICATION SPEC	-		
3 PLC ± -		114-2088	SIZE	CAGE CODE	DRAWING NO
4 PLC ± -		WEIGHT -	A3	00779	C-63130
ANGLES ± -			RESTRICTED TO		
MATERIAL SEE TABLE	FINISH SEE TABLE	CUSTOMER DRAWING		SCALE 8:1	SHEET 1 OF 1
				REV L4	