

LTC4265 IEEE 802.3at Power over Ethernet Powered Device Controller

DESCRIPTION

Demonstration circuit 1415A is an Ethernet Alliance™ certified IEEE 802.3at compliant Power over Ethernet (PoE) powered device (PD). It features the [LTC®4265](#), a third-generation (PD) interface controller. It can handle up to 25.5W and recognizes 2-event classification.

The LTC4265 is compliant to the IEEE 802.3at standard. It can handle up to 25.5W and recognizes 2-event classification.

The LTC4265 includes the PD controller circuitry and power MOSFET integrated in a 3mm × 4mm 12-pin DFN package.

The DC1415A board includes the entire front end of a typical PD; RJ45 connector, Ethernet magnetics, bridge rectifiers, surge protection, and PD controller, all in a

1"×2" board. Two status indicator LEDs are also included: one shows the PSE is powering the PD; and the other shows the PSE performed 2-event classification. A small load sufficient to assure the PSE maintains power to the PD is also included.

The LTC4265 features complementary PWRGD and $\overline{\text{PWRGD}}$ outputs to facilitate interface to a wide range of off-the-shelf DC/DC converters.

Simply connect the outputs of the DC1415A to the DC/DC converter that is right for the application. Analog Devices offers many DC/DC converter demo boards that can be used with the DC1415A.

[Design files for this circuit board are available.](#)

All registered trademarks and trademarks are the property of their respective owners.

QUICK START PROCEDURE

1. To evaluate the LTC4265 without a load, skip to step 3.
2. To evaluate the LTC4265 with a load, choose the connection diagram based on the type of load and wire the DC1415A board to the load as shown.
 - a. Use Figure 1 if the DC/DC converter has sufficient built-in start-up delay. The LTC4265 limits the current to 100mA (typical) during startup; if the DC/DC converter tries to draw more than 100mA (typical) during this time then startup will fail. The required delay depends on the input capacitance and under-voltage lockout threshold of the particular converter.
 - b. Use Figure 2 or Figure 3 if the startup delay could be an issue.
 - c. Use Figure 4 if the load is resistive.
3. Connect the output of the PSE to J1 on the DC1415A board with a CAT5e or CAT6 cable.
4. Verify LED2 is lit, indicating the PSE has successfully detected and powered the PD. LED1 will also be lit if the PSE performed 2-event classification. See Figure 5.



QUICK START PROCEDURE

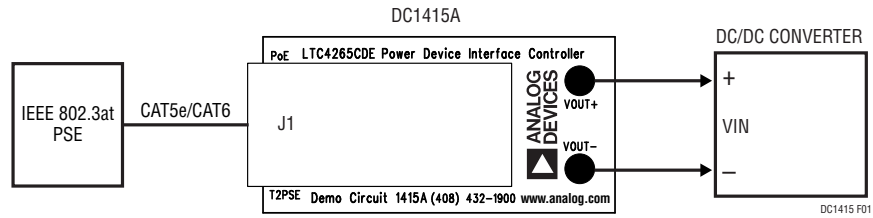

Figure 1. Basic Connection to a DC/DC Converter

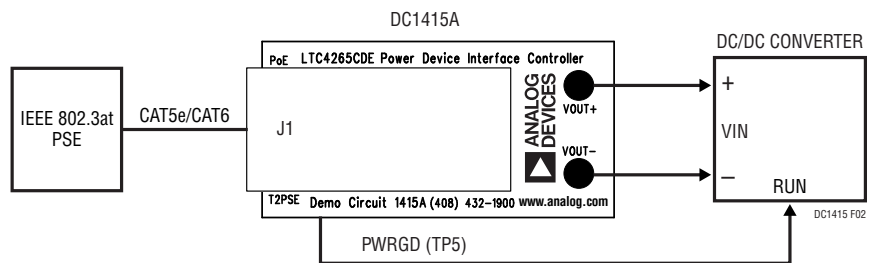

Figure 2. Connecting to a DC/DC Converter with Active-High RUN Pin

QUICK START PROCEDURE

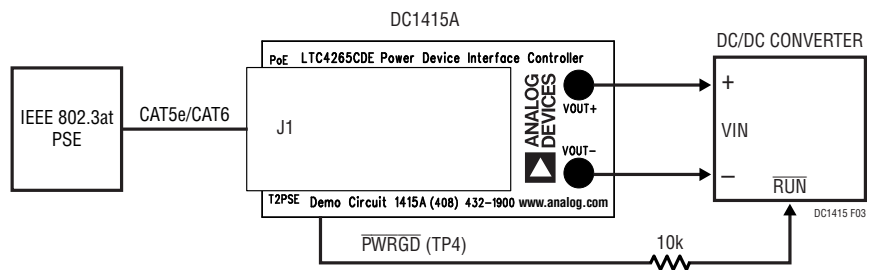

Figure 3. Connecting to a DC/DC Converter with Active-Low RUN Pin

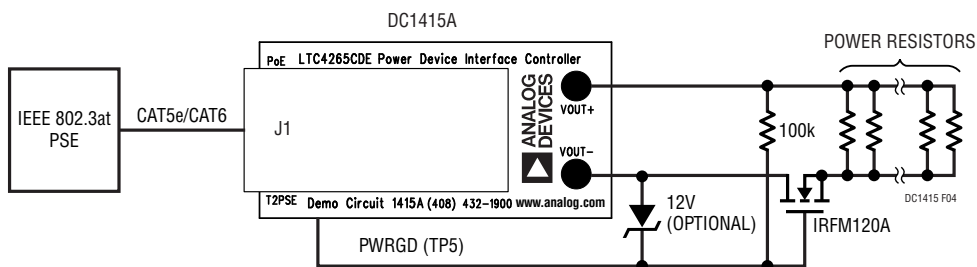

Figure 4. Connecting to a Resistive Load

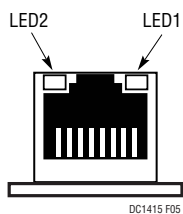

Figure 5. DC1415 LEDs

OPERATION

Classification Signature

The RCLASS resistor (R3) determines the classification signature. The DC1415A board comes with $R3 = 30.9\Omega$ for class 4. If a different class signature is required, simply change R3 according to Table 1.

Table 1. RCLASS Resistor Values

PD CLASS	RCLASS (Ω , 1%)
0	Open (no resistor)
1	124
2	69.8
3	45.3
4	30.9

LED Indicators

There are two LEDs on the front of J1 as shown in Figure 5. In a typical PD application a PHY chip would drive these LEDs to indicate the status of the Ethernet link or traffic activity; however, on the DC1415A board the LTC4265 drives the LEDs to indicate PoE status.

The $\overline{\text{PWRGD}}$ pin of the LTC4265 drives LED2. LED2 is lit continuously while the PD is powered by the PSE. To disable LED2 remove R2.

The $\overline{\text{T2PSE}}$ pin drives LED1. LED1 will be lit if the PSE performed 2-event classification, indicating the PSE is Type 2. To disable LED1 remove R1.

Power Supply Startup

The LTC4265 limits the current to 100mA (typical) during startup. If the DC/DC converter attempts to draw more than 100mA (typical) while the LTC4265 is still limiting the current, then startup will fail.

Many DC/DC converters include startup delay sufficient to prevent this situation. Such a converter may be connected to the DC1415A board as shown in Figure 1.

However, some DC/DC converters have short startup delays. To avoid startup problems it is recommended to use either the PWRGD or $\overline{\text{PWRGD}}$ output to inhibit startup of the DC/DC converter until the LTC4265 finishes limiting the inrush current.

Use PWRGD if the DC/DC converter has an active-high control input, as shown in Figure 2.

Use $\overline{\text{PWRGD}}$ if the DC/DC converter has an active low control input, as shown in Figure 3. A 10k resistor limits the current between PWRGD and $\overline{\text{RUN}}$ in the event of a voltage transient at the J1 input. A resistive load may be used to evaluate the thermal properties of the LTC4265; in this case use a series MOSFET to prevent startup problems, as shown in Figure 4. PWRGD holds the MOSFET gate low until the LTC4265 is ready to supply full current.

CAUTION: The MOSFET may be destroyed if its gate is pulled all the way to VOUT+ by the pull-up resistor. The MOSFET is protected by a 14V clamp inside the LTC4265; however, if the wire to PWRGD were disconnected—or mistakenly connected to $\overline{\text{PWRGD}}$ —then the MOSFET would not be protected. Therefore it is recommended to use a Zener diode connected directly across the gate and source pins of the MOSFET as shown in Figure 4.

Minimum LOAD

The PSE may discontinue power if the load current is below 10mA. The DC1415A includes a 3k load (RMPS) across its output to prevent the PSE from turning off power. RMPS may be removed if the DC1415A is connected to a load that draws at least 10mA continuously.

SCHEMATIC DIAGRAM

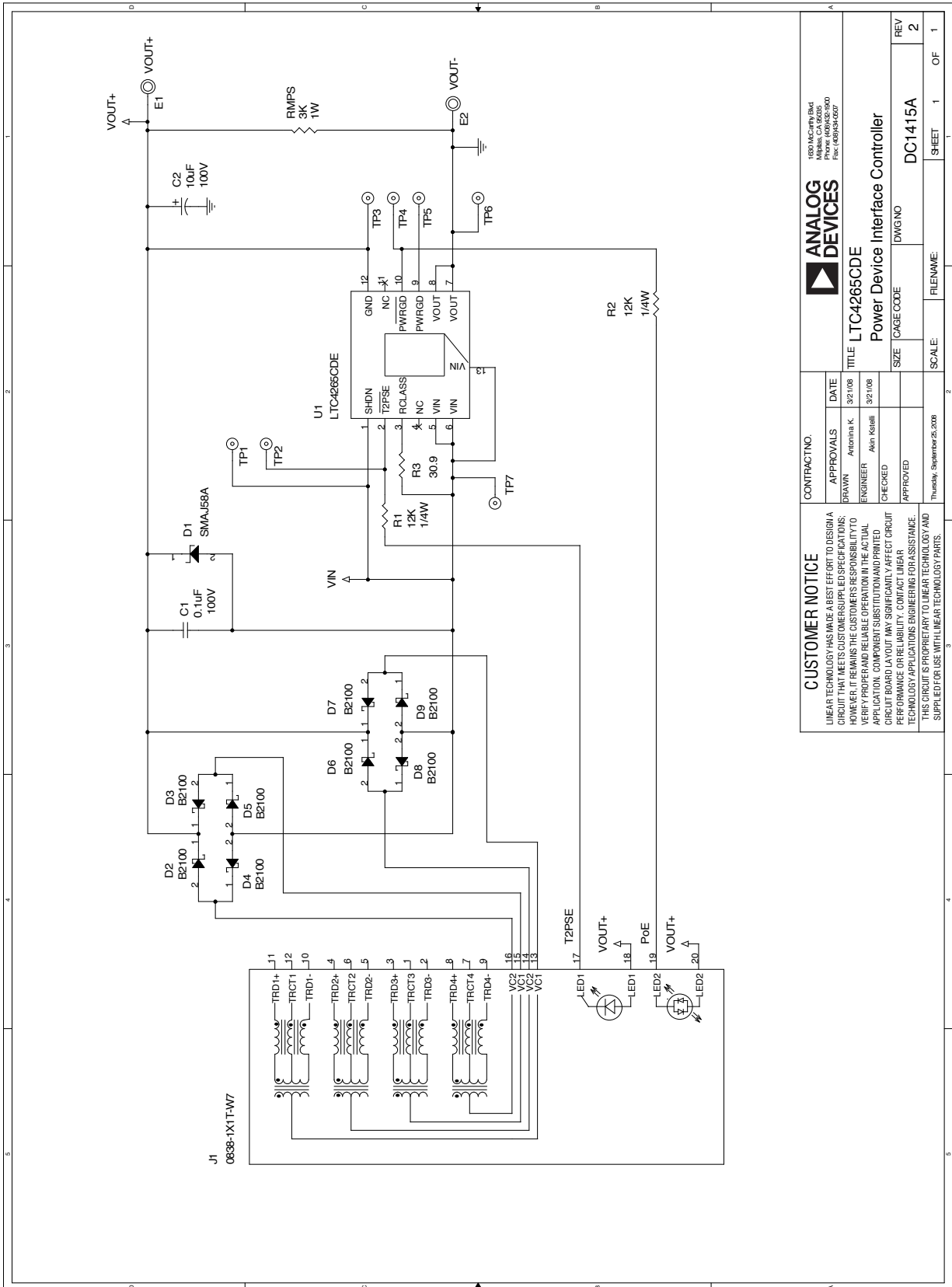

ANALOG DEVICES		1629 McCarty Rd Mills, CA 95055 Phone (925) 924-2000 Fax (925) 924-2029	
TITLE		LTC4265CDE	
Power Device Interface Controller		SIZE	DC1415A
CONTRACT NO.	APPROVALS	DATE	REV
	DRAWN Antonia K.	3/2/08	2
	ENGINEER Alan Kothall	3/2/08	1
	CHECKED		OF
	APPROVED		1
	FILENAME:	SCALE:	SHEET
	Thursday, September 25, 2008		1

CUSTOMER NOTICE

LINEAR TECHNOLOGY HAS MADE A BEST EFFORT TO DESIGN A CIRCUIT THAT MEETS CUSTOMER SUPPLIED SPECIFICATIONS; HOWEVER, IT REMAINS THE CUSTOMER'S RESPONSIBILITY TO VERIFY PROPER AND RELIABLE OPERATION IN THE ACTUAL APPLICATION. COMPONENT SUBSTITUTION AND PRINTED CIRCUIT BOARD LAYOUT MAY SIGNIFICANTLY AFFECT CIRCUIT PERFORMANCE OR RELIABILITY. CONTACT LINEAR TECHNOLOGY APPLICATIONS ENGINEERING FOR ASSISTANCE.

THIS CIRCUIT IS PROPRIETARY TO LINEAR TECHNOLOGY AND SUPPLIED FOR USE WITH LINEAR TECHNOLOGY PARTS.



ESD Caution

ESD (electrostatic discharge) sensitive device. Charged devices and circuit boards can discharge without detection. Although this product features patented or proprietary protection circuitry, damage may occur on devices subjected to high energy ESD. Therefore, proper ESD precautions should be taken to avoid performance degradation or loss of functionality.

Legal Terms and Conditions

By using the evaluation board discussed herein (together with any tools, components documentation or support materials, the "Evaluation Board"), you are agreeing to be bound by the terms and conditions set forth below ("Agreement") unless you have purchased the Evaluation Board, in which case the Analog Devices Standard Terms and Conditions of Sale shall govern. Do not use the Evaluation Board until you have read and agreed to the Agreement. Your use of the Evaluation Board shall signify your acceptance of the Agreement. This Agreement is made by and between you ("Customer") and Analog Devices, Inc. ("ADI"), with its principal place of business at One Technology Way, Norwood, MA 02062, USA. Subject to the terms and conditions of the Agreement, ADI hereby grants to Customer a free, limited, personal, temporary, non-exclusive, non-sublicensable, non-transferable license to use the Evaluation Board FOR EVALUATION PURPOSES ONLY. Customer understands and agrees that the Evaluation Board is provided for the sole and exclusive purpose referenced above, and agrees not to use the Evaluation Board for any other purpose. Furthermore, the license granted is expressly made subject to the following additional limitations: Customer shall not (i) rent, lease, display, sell, transfer, assign, sublicense, or distribute the Evaluation Board; and (ii) permit any Third Party to access the Evaluation Board. As used herein, the term "Third Party" includes any entity other than ADI, Customer, their employees, affiliates and in-house consultants. The Evaluation Board is NOT sold to Customer; all rights not expressly granted herein, including ownership of the Evaluation Board, are reserved by ADI. CONFIDENTIALITY. This Agreement and the Evaluation Board shall all be considered the confidential and proprietary information of ADI. Customer may not disclose or transfer any portion of the Evaluation Board to any other party for any reason. Upon discontinuation of use of the Evaluation Board or termination of this Agreement, Customer agrees to promptly return the Evaluation Board to ADI. ADDITIONAL RESTRICTIONS. Customer may not disassemble, decompile or reverse engineer chips on the Evaluation Board. Customer shall inform ADI of any occurred damages or any modifications or alterations it makes to the Evaluation Board, including but not limited to soldering or any other activity that affects the material content of the Evaluation Board. Modifications to the Evaluation Board must comply with applicable law, including but not limited to the RoHS Directive. TERMINATION. ADI may terminate this Agreement at any time upon giving written notice to Customer. Customer agrees to return to ADI the Evaluation Board at that time. LIMITATION OF LIABILITY. THE EVALUATION BOARD PROVIDED HEREUNDER IS PROVIDED "AS IS" AND ADI MAKES NO WARRANTIES OR REPRESENTATIONS OF ANY KIND WITH RESPECT TO IT. ADI SPECIFICALLY DISCLAIMS ANY REPRESENTATIONS, ENDORSEMENTS, GUARANTEES, OR WARRANTIES, EXPRESS OR IMPLIED, RELATED TO THE EVALUATION BOARD INCLUDING, BUT NOT LIMITED TO, THE IMPLIED WARRANTY OF MERCHANTABILITY, TITLE, FITNESS FOR A PARTICULAR PURPOSE OR NON-INFRINGEMENT OF INTELLECTUAL PROPERTY RIGHTS. IN NO EVENT WILL ADI AND ITS LICENSORS BE LIABLE FOR ANY INCIDENTAL, SPECIAL, INDIRECT, OR CONSEQUENTIAL DAMAGES RESULTING FROM CUSTOMER'S POSSESSION OR USE OF THE EVALUATION BOARD, INCLUDING BUT NOT LIMITED TO LOST PROFITS, DELAY COSTS, LABOR COSTS OR LOSS OF GOODWILL. ADI'S TOTAL LIABILITY FROM ANY AND ALL CAUSES SHALL BE LIMITED TO THE AMOUNT OF ONE HUNDRED US DOLLARS (\$100.00). EXPORT. Customer agrees that it will not directly or indirectly export the Evaluation Board to another country, and that it will comply with all applicable United States federal laws and regulations relating to exports. GOVERNING LAW. This Agreement shall be governed by and construed in accordance with the substantive laws of the Commonwealth of Massachusetts (excluding conflict of law rules). Any legal action regarding this Agreement will be heard in the state or federal courts having jurisdiction in Suffolk County, Massachusetts, and Customer hereby submits to the personal jurisdiction and venue of such courts. The United Nations Convention on Contracts for the International Sale of Goods shall not apply to this Agreement and is expressly disclaimed.