

CROSS RECESSED
PAN HEAD

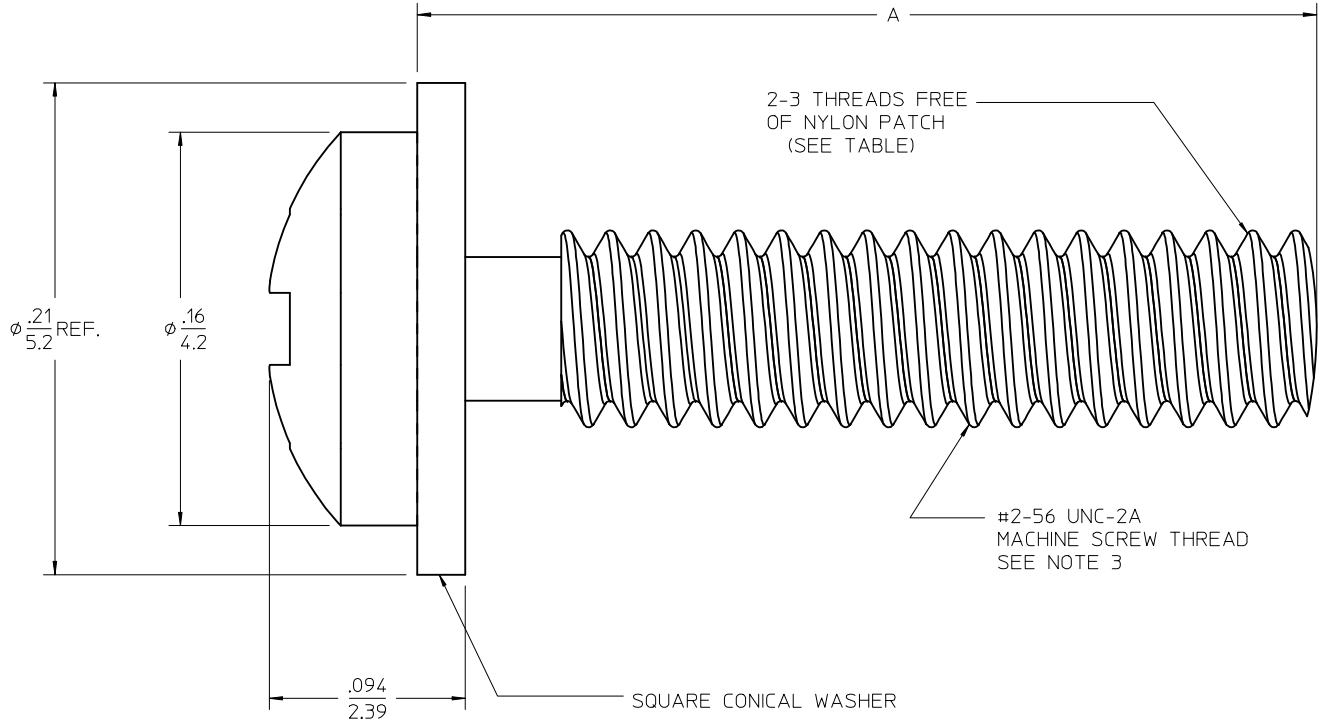

| PART NUMBER | A ±.020/0.51 | NYLON PATCH |
|-------------|--------------|-------------|
| 73774-1000 | .375/9.53 | NO |
| 73774-1100 | .375/9.53 | YES |
| 73774-1005 | .500/12.70 | NO |
| 73774-1010 | .625/15.88 | NO |
| 73774-1015 | .250/6.35 | NO |

- NOTES:
 1. MATERIAL:
 SCREW: SAE 1022
 WASHER: SAE 1050
 2. FINISH: CLEAR TRIVALENT CHROMATE
 3. PLATING: 100 TO 300 MICROINCHES/2.54 TO 7.62 MICROMETERS ZINC PLATE
 4. SEE CONNECTOR PRODUCT SPECIFICATION FOR RECOMMENDED TORQUE REQUIREMENTS.

| | | | | | | |
|---|-----------------|--|--|---|--------------|------------------------|
| REVISE NOTE 4 EC NO: UCP2016-3925 DRWNS:VANG01 2016/04/07 CHKD:MWOLFE 2016/04/07 APPR:SMILLER 2016/04/12 | QUALITY SYMBOLS | GENERAL TOLERANCES (UNLESS SPECIFIED) | DIMENSION STYLE | SCALE | DESIGN UNITS | THIRD ANGLE PROJECTION |
| | ▽=0 | mm INCH | IN/MM | 25:1 | INCH | |
| | ▽=0 | 4 PLACES ± --- ± --- | DRAWN BY DATE | TITLE | | |
| | ▽=0 | 3 PLACES ± --- ± .005 | MWOLFE 2012/03/09 | #2-56 SQUARE CONICAL SEMS MACHINE SCREW | | |
| | | 2 PLACES ± 0.13 ± .010 | CHECKED BY DATE | | | |
| | | 1 PLACE ± 0.25 ± --- | SDANNELLEY 2012/03/09 | | | |
| | | 0 PLACE ± ± | APPROVED BY DATE | DOCUMENT NO. | | |
| | | ANGULAR ±1/2° | SMILLER 2012/03/12 | SD-73774-003 | | |
| | | DRAFT WHERE APPLICABLE MUST REMAIN WITHIN DIMENSIONS | MATERIAL NO. | SHEET NO. | | |
| | | | SEE TABLE | 1 OF 1 | | |
| | | | SIZE THIS DRAWING CONTAINS INFORMATION THAT IS PROPRIETARY TO MOLEX INCORPORATED AND SHOULD NOT BE USED WITHOUT WRITTEN PERMISSION | | | |