

DLPC410 DMD Digital Controller

1 Features

- Operates the Following DLP® Chips:
 - DLP650LNIR, DLP7000, DLP7000UV, DLP9500, and DLP9500UV DMDs
 - DLPA200 DMD Micromirror Driver
 - DLPR410 Configuration PROM
- Enables High Speed DMD Pattern Rates
 - 1-Bit Binary Pattern Rates up to 32 kHz
 - 8-Bit Monochrome Pattern Rates up to 4 kHz
- 400 MHz Input Data Clock Rates
- 64-Bit 2xLVDS Data Bus Interfaces In/Out
- Supports Random Row and LOAD4 DMD Addressing
- Compatible With a Variety of User Defined Processors or FPGAs

2 Applications

- Industrial:
 - Direct Imaging Lithography
 - 3D Printing (SLA and SLS)
 - 3D Machine Vision
 - 3D Scanners for Robotics & Inspection
 - Dynamic Grayscale Laser Marking and Coding
 - Industrial Printing
 - High Speed Projection and Advanced Imaging
 - Ablation and Repair Systems
 - Microscopes

3 Description

The DLPC410 is a digital controller that supports five DMD options: DLP650LNIR, DLP7000, DLP7000UV, DLP9500, and DLP9500UV. It is the convenient, high-speed data and control interface between the application electronics and the DMD. The DLPC410 provides DMD Mirror Clocking Pulses (Resets) and timing information to the DLPA200 DMD Micromirror Driver. The device is configured with firmware stored in the DLPR410 PROM.

This family of chipsets enables pixel data rates up to 48 Gigabits per second (Gbps) with the option for single, dual, quad, and global Resets. In addition, random row addressing and LOAD4 capabilities are offered. Often the family of chips is used when designing UV and NIR systems such as direct imaging lithography, 3D printing, and laser marking systems that need fast throughput and pixel accurate control.

Device Information⁽¹⁾

PART NUMBER	PACKAGE	BODY SIZE (NOM)
DLPC410	FCBGA (676)	27.00 mm x 27.00 mm

(1) For all available packages, see the orderable addendum at the end of the data sheet.

Simplified Application

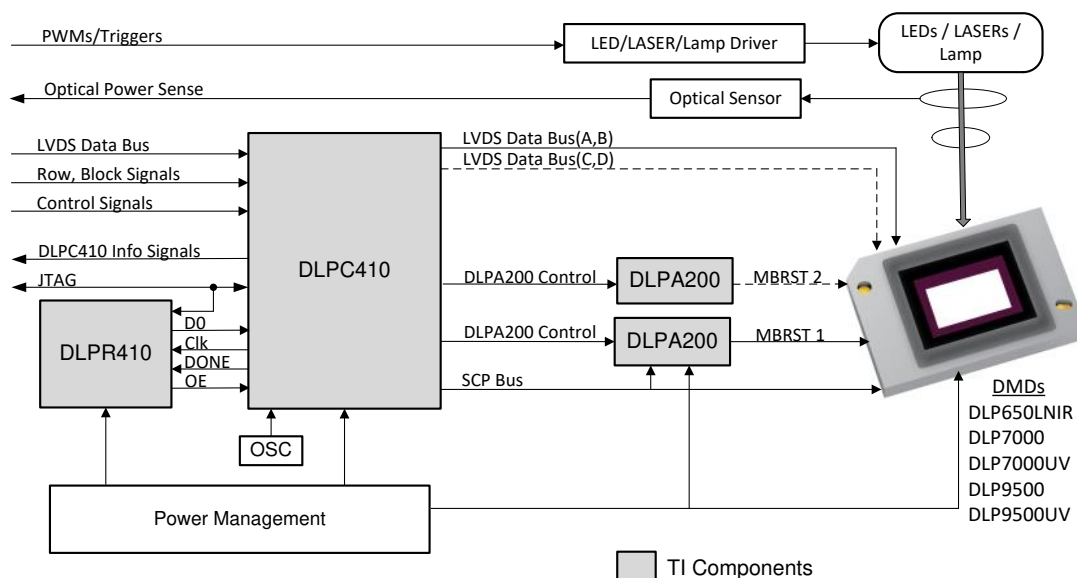

Table of Contents

1 Features	1	9 Application and Implementation	59
2 Applications	1	9.1 Application Information.....	59
3 Description	1	9.2 Typical Application	59
4 Revision History	2	9.3 Initialization Setup	61
5 Description (continued)	5	10 Power Supply Recommendations	64
6 Pin Configuration and Functions	6	10.1 Power Down Operation.....	64
7 Specifications	20	11 Layout	64
7.1 Absolute Maximum Ratings	20	11.1 Layout Guidelines	64
7.2 ESD Ratings.....	20	11.2 Layout Example	66
7.3 Recommended Operating Conditions.....	20	11.3 DLPC410 Chipset Connections	67
7.4 Electrical Characteristics.....	21	12 Device and Documentation Support	76
7.5 Timing Requirements	21	12.1 Device Support.....	76
8 Detailed Description	23	12.2 Documentation Support	77
8.1 Overview	23	12.3 Support Resources	77
8.2 Functional Block Diagrams	24	12.4 Trademarks	77
8.3 Feature Description.....	26	12.5 Electrostatic Discharge Caution.....	77
8.4 Device Functional Modes.....	49	12.6 Glossary	77
8.5 Programming.....	58	13 Mechanical, Packaging, and Orderable Information	77

4 Revision History

NOTE: Page numbers for previous revisions may differ from page numbers in the current version.

Changes from Revision F (February 2019) to Revision G	Page
• Removed extraneous setup/hold diagram (Figure 3) for COMP_DATA and NS_FLIP	22
• Fixed "BLKAD(10:0)" to "BLKAD(3:0)" on block diagrams	24
• Changed Figure 8 Row Cycle Diagram to match Table 9 and Table 10 pixel mapping	37
• Changed DDC_VERSION(3:0) to DDC_VERSION(2:0) to reflect hardware pinout	49
• Corrected initialization sequence to reflect both DLPA200s configured in two steps	61
• Deleted "DMD Device OK" debug section as debug signals are not assigned for output on ECP pins (reserved).	62

Changes from Revision E (January 2019) to Revision F	Page
• Modified functions for TP4-TP31	15
• Corrected DLP650LNIR Bus A Pixel Mapping	38
• Corrected DLP650LNIR Bus A Pixel Mapping	39
• Corrected DLP650LNIR Bus B Pixel Mapping	40
• Corrected DLP650LNIR Bus B Pixel Mapping	41
• Removed ECP2M calibration feedback pins	62
• Removed ECP2M DLPA200 Init Status pin	62
• Removed ECP2M DMD Init Status pin	62
• Removed the ECP2_M TP20 referring to AA18 instead	63

Changes from Revision D (December 2018) to Revision E	Page
• Changed $\overline{\text{ARST}}$ description that was incorrectly described in DLPS024 Revision D.	48

Changes from Revision C (December 2015) to Revision D	Page
• Added new DLP650LNIR to supported DMDs (multiple)	1
• Changed input data clock rate to 400 MHz only	1
• Updated Applications list for latest markets	1
• Changed Simplified Diagram to include new DLP650LNIR	1
• Changed pin DDC_SPARE_0 to $\overline{\text{LOAD4}}$	16
• Removed 200MHz - new revision tested at 400MHz only	21
• Re-organization of Detailed Description for flow, clarity, and readability	23
• Added DLP650LNIR functional block diagram	24
• Updated DLP7000 functional block diagram (no technical changes).....	25
• Updated DLP9500 functional block diagram (no technical changes).....	26
• Added new DLP650LNIR DMD Characteristics to Table 2	28
• Added DLP650LNIR DMD to Row Addressing and Table 11	41
• Re-worded the Block Operations section for clarity.	45
• Added new DLP650LNIR DMD Characteristics	48
• Added/edited LOAD4 sections, enabled by DLPR410A.....	49
• Removed reference to 200 MHz input data clock.	49
• Added the DLP650LNIR and its block load time to Table 16	51
• Added Table 17	54
• Combined Application Example Diagrams to encompass all DLPC410 supported DMDs	60
• Added DLP650LNIR to Detailed Design procedure section	61
• Added Figure 24 - DLP650LNIR window transmittance	61
• Changed "Generate Data" to "Present Data to DLPC410"	63
• Changed "DLPC410 DMD data signals" to "LVDS data bus differential pairs"	65
• Removed reference to TI part number 2510440-001.	76
• Removed Discovery Chipset data sheet, added DLP650LNIR data sheet, corrected other device names	77

Changes from Revision B (June 2013) to Revision C	Page
• Added <i>ESD Rating</i> table, <i>Feature Description</i> section, <i>Device Functional Modes</i> , <i>Application and Implementation</i> section, <i>Power Supply Recommendations</i> section, <i>Layout</i> section, <i>Device and Documentation Support</i> section, and <i>Mechanical, Packaging, and Orderable Information</i> section	1
• Removed references to Discovery 4100 and deleted DLPR4101 throughout document.....	1
• Added DLP7000UV and DLP9500UV to <i>Features and Description</i>	1
• Added note - Xilinx System Monitor analog supply & ground - "must be connected to ground" (AVDD_0 & AVSS_0).....	7
• Changed "DAD A" descriptions to "DLPA200 number 1" and "DAD B" descriptions to "DLPA200 number 2"	7
• Reversed DDC_Bnn_VR pairs pullups / pulldowns (for nn =12, 15, and 16)	8
• Changed Pin # C22 name from DDC_B11_VRP (duplicate) to DDC_B15_VRP	8
• Added "Not used" to description for DMD_B_RESET and $\overline{\text{DMD_B_SCPEN}}$	14
• Added TP14 and TP17 note - Xilinx Temperature Diode	14
• Added "in Reference Design" to ECP2 Mictor pin notes	14
• Changed ECP2 pin description from "Not Defined" to "Not Used"	14
• Added ECP2_M_TP[3:29] descriptions and active state.....	15
• Deleted duplicate pin numbers M13 and M14	16
• Changed Description from "DMD Power" to "DMD Power Good indicator"	16
• Changed duplicate pin name from RSVD_0 to RSVD_1	17
• Updated pin description for SCPDI and SCPDO	17

• Changed STEPVCC to connect to ground, active "Hi" to "-", and clock to "-"	17
• Changed Description from "JTAG Data Clock" to "JTAG Data"	17
• Changed pin names for VCCO_n_n pins to list each pin separately	18
• Added note about Xilinx System Monitor differential pins (VN_0 & VP_0) and reference voltage (VREFN_0 & VREFP_0).....	18
• Changed Description from "DMD Reset Watchdog" to "DMD Mirror Clocking Pulse Watchdog"	19
• Deleted duplicate pin numbers in "UNUSED" pin list.....	19
• Updated the functional block diagrams	25
• Moved DLP7000 / DLP7000UV and DLP9500 / DLP9500UV Example Block Diagrams from Functional Block Diagram section to Typical Application Section	26
• Deleted the "Step DMD SRAM Memory Voltage" and "Load 4" Enhanced Functionality (with DLPR4101 PROM only)" sections	48
• Updated the embedded example block diagrams	60
• Added DLP7000UV and DLP9500UV well suited for direct imaging lithography, 3D printing, and UV applications	61
• Added Debugging Guidelines section	61
• Changed maximum differential trace length from 100 to 150 matching Table 13.....	65
• Added DLP7000UV and DLP9500UV Related Documentation	77

Changes from Revision A (September 2012) to Revision B
Page

• Changed Feature From: 1-Bit Binary Pattern Rates up to 32-kHz To: 1-Bit Binary Pattern Rates up to 32-kHz (up to 48-kHz when used with DLPR4101).....	1
• Added Section "Load 4" Enhanced Functionality (with DLPR4101 PROM only).....	49
• Added DLPR4101 to DLPR410	77

Changes from Original (August 2012) to Revision A
Page

• Changed the device From: Product Preview to Production.....	1
---	---

5 Description (continued)

In DLP-based electronics solutions, image data is 100% digital from the DLPC410 input port to the projected image. The image stays in digital form and is never converted into an analog signal. The DLPC410 processes the digital input image and converts the data into a format needed by the image on the DMD. The DMD then steers the light using binary pulse-width modulation (PWM) for each pixel mirror.

The DLPC410 is the DMD digital controller that controls the DLP650LNIR, DLP7000, DLP7000UV, DLP9500, and DLP9500UV DMDs (see [Functional Block Diagram](#), [Functional Block Diagram](#), and [Functional Block Diagram](#)). The DLPC410 provides developers easy access to the DMD as well as high speed, independent micromirror control. See the list of required chipset components for each DMD solution in [Device Configurations](#) table:

Table 1. DLPC410 Device Configurations

DMD	DMD MICROMIRROR DRIVER	DMD DIGITAL CONTROLLER
DLP9500 DLP 0.95 1080p 2xLVDS Type A DMD	2 ea. DLPA200	DLPC410 (+ DLPR410 Configuration PROM)
DLP9500UV DLP 0.95 UV 1080p 2xLVDS Type A DMD	2 ea. DLPA200	
DLP7000 DLP 0.7 XGA 2xLVDS Type A DMD	1 ea. DLPA200	
DLP7000UV DLP 0.7 UV XGA 2xLVDS Type A DMD	1 ea. DLPA200	
DLP650LNIR 0.65 NIR WXGA S450 DMD	1 ea. DLPA200	

Reliable function and operation of the DLPC410 requires that it be used in conjunction with the other components of the chipset in [DLPC410 Device Configurations](#) table. For more information on the chipset components, see the data sheets in [Related Documentation](#).

6 Pin Configuration and Functions

ZYR Package
676-Pin FCBGA
Bottom View

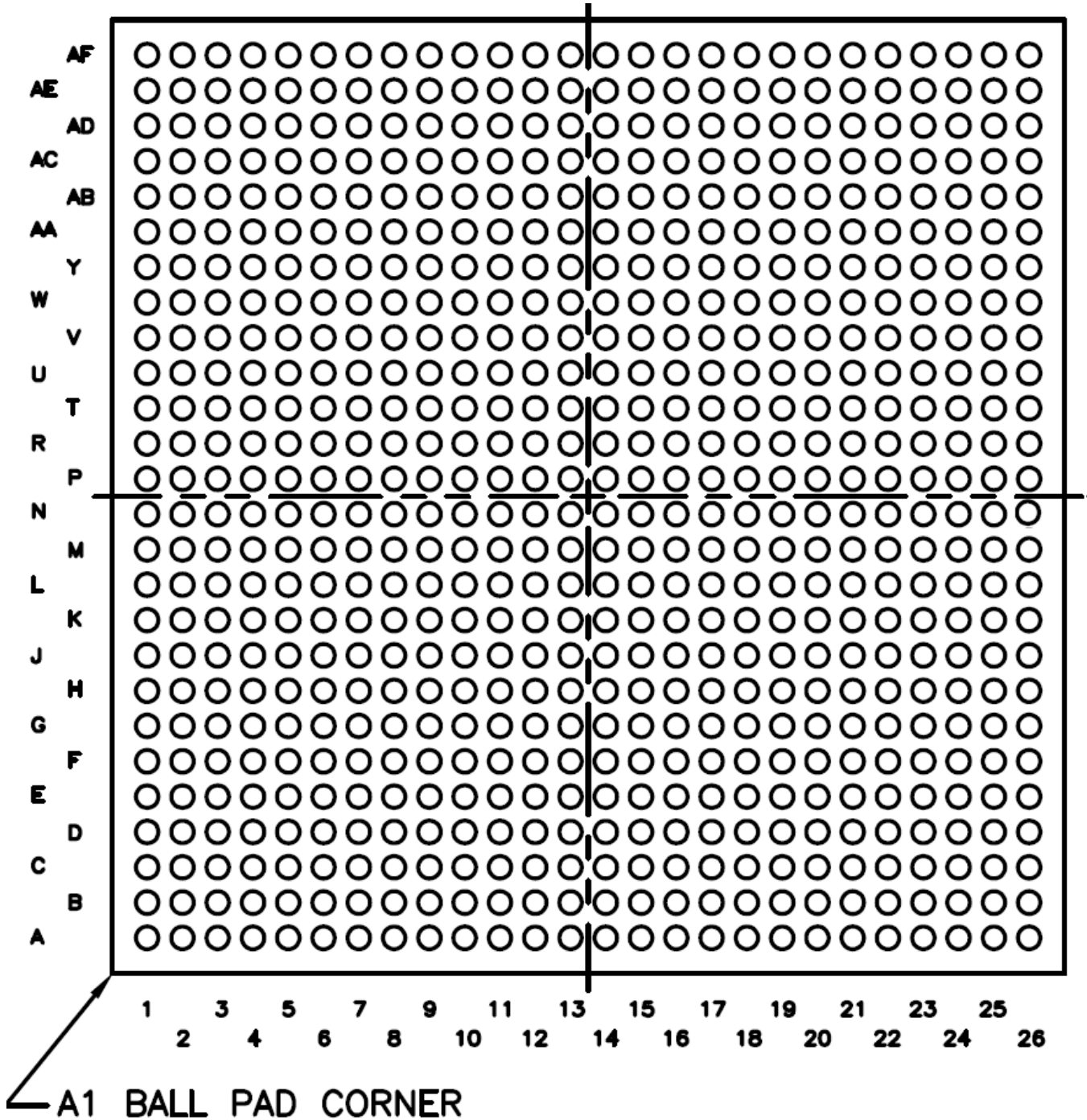

Pin Functions

PIN		TYPE	SIGNAL	TERMINATION /NOTES	ACTIVE (Hi or Lo)	CLOCK	DATA RATE	DESCRIPTION
NAME	NO.							
APPS_CNTL_DPN	F7	-	-	This pair connected with 100 Ω resistor between pair.	-	-		Not Used
APPS_CNTL_DPP	E7	-	-		-	-		Not Used
ARST	AC13	I	LVC MOS25_S_ 12_I		Lo	-		DLPC410 Reset
AVDD_0	M14	-	-	Not used - connect to Ground (no name in Reference Design)	-	-		Xilinx System Monitor analog supply - (not used - must be connected to ground)
AVSS_0	M13	-	-	Not used - connect to Ground (no name in Reference Design)	-	-		Xilinx System Monitor analog ground - (not used - must be connected to ground)
BLKAD_0	E12	I	LVC MOS25_S_ 12_I		Hi = 1	DDC_DCLK_[A,B,C,D]		Block Address bit 0
BLKAD_1	D13	I	LVC MOS25_S_ 12_I		Hi = 1	DDC_DCLK_[A,B,C,D]		Block Address bit 1
BLKAD_2	E13	I	LVC MOS25_S_ 12_I		Hi = 1	DDC_DCLK_[A,B,C,D]		Block Address bit 2
BLKAD_3	F13	I	LVC MOS25_S_ 12_I		Hi = 1	DDC_DCLK_[A,B,C,D]		Block Address bit 3
BLKMD_0	H13	I	LVC MOS25_S_ 12_I		Hi = 1	DDC_DCLK_[A,B,C,D]		Block Mode Bit 0
BLKMD_1	H14	I	LVC MOS25_S_ 12_I		Hi = 1	DDC_DCLK_[A,B,C,D]		Block Mode Bit 1
CLKIN_R	AD13	I	LVC MOS25_S_ 12_I		-	Reference Clock		Reference Clock
COMP_DATA	G19	I	LVC MOS25_S_ 12_I		Hi	DDC_DCLK_[A,B,C,D]		Compliment Data (0 <-> 1)
CS_B_0	N18	-	-	1 kΩ pulldown to ground	Lo	-		Xilinx Config
D_OUT_BUSY_0	W11	-	NC	Do not connect	-	-		Not Used
DAD_A_ADDR0	E1	O	LVC MOS25_F_ 12_O	Connected to DLPA200 number 1 Address 0 pin	Hi = 1	-		DLPA200 Number 1 Reset Block bit 0
DAD_A_ADDR1	E2	O	LVC MOS25_F_ 12_O	Connected to DLPA200 Number 1 Address 1 pin	Hi = 1	-		DLPA200 Number 1 Reset Block bit 1
DAD_A_ADDR2	E3	O	LVC MOS25_F_ 12_O	Connected to DLPA200 Number 1 Address 2 pin	Hi = 1	-		DLPA200 Number 1 Reset Block bit 2
DAD_A_ADDR3	F3	O	LVC MOS25_F_ 12_O	Connected to DLPA200 Number 1 Address 3 pin	Hi = 1	-		DLPA200 Number 1 Reset Block bit 3
DAD_A_MODE0	C1	O	LVC MOS25_F_ 12_O	Connected to DLPA200 Number 1 Mode 0 pin	Hi = 1	-		DLPA200 Number 1 Mode bit 0
DAD_A_MODE1	D1	O	LVC MOS25_F_ 12_O	Connected to DLPA200 Number 1 Mode 1 pin	Hi = 1	-		DLPA200 Number 1 Mode bit 1
DAD_A_SCPEN	AE3	O	LVC MOS25_F_ 12_O	Connected to DLPA200 Number 1 SCPEN pin	Lo	-		DLPA200 Number 1 SCP Communication Enable
DAD_A_SEL0	AB12	O	LVC MOS25_F_ 12_O	Connected to DLPA200 Number 1 SEL 0 pin	Hi = 1	-		DLPA200 Number 1 Address bit 0
DAD_A_SEL1	AC12	O	LVC MOS25_F_ 12_O	Connected to DLPA200 Number 1 SEL 1 pin	Hi = 1	-		DLPA200 Number 1 Address bit 1
DAD_A_STROBE	AF3	O	LVC MOS25_F_ 12_O	Connected to DLPA200 Number 1 STROBE pin	Hi	-		DLPA200 Number 1 Transition Strobe
DAD_B_ADDR0	E26	O	LVC MOS25_F_ 12_O	Connected to DLPA200 Number 2 Address 1 pin	Hi = 1	-		DLPA200 Number 2 Reset Block bit 0
DAD_B_ADDR1	E25	O	LVC MOS25_F_ 12_O	Connected to DLPA200 Number 2 Address 2 pin	Hi = 1	-		DLPA200 Number 2 Reset Block bit 1
DAD_B_ADDR2	F25	O	LVC MOS25_F_ 12_O	Connected to DLPA200 Number 2 Address 3 pin	Hi = 1	-		DLPA200 Number 2 Reset Block bit 2
DAD_B_ADDR3	F24	O	LVC MOS25_F_ 12_O	Connected to DLPA200 Number 2 Address 0 pin	Hi = 1	-		DLPA200 Number 2 Reset Block bit 3
DAD_B_MODE0	D26	O	LVC MOS25_F_ 12_O	Connected to DLPA200 Number 2 Mode 0 pin	Hi = 1	-		DLPA200 Number 2 Mode bit 0
DAD_B_MODE1	D25	O	LVC MOS25_F_ 12_O	Connected to DLPA200 Number 2 Mode 1 pin	Hi = 1	-		DLPA200 Number 2 Mode bit 1
DAD_B_SCPEN	AB19	O	LVC MOS25_F_ 12_O	Connected to DLPA200 Number 2 SCPEN pin	Lo	-		DLPA200 Number 2 SCP Communication Enable
DAD_B_SEL0	R22	O	LVC MOS25_F_ 12_O	Connected to DLPA200 Number 2 SEL 0 pin	Hi = 1	-		DLPA200 Number 2 Address bit 0
DAD_B_SEL1	R23	O	LVC MOS25_F_ 12_O	Connected to DLPA200 Number 2 SEL 1 pin	Hi = 1	-		DLPA200 Number 2 Address bit 1
DAD_B_STROBE	AB20	O	LVC MOS25_F_ 12_O	Connected to DLPA200 Number 2 STROBE pin	Hi	-		DLPA200 Number 2 Transition Strobe

Pin Functions (continued)

PIN		TYPE	SIGNAL	TERMINATION /NOTES	ACTIVE (Hi or Lo)	CLOCK	DATA RATE	DESCRIPTION
NAME	NO.							
DAD_INIT	AF4	O	LVC MOS25_F_12_O	Connected to DLPA200 Number 1 and Number 2 RESET pin	Hi	-		DLPA200 Number 1 / Number 2 Init
DAD_OE	AF5	O	LVC MOS25_F_12_O	Connected to DLPA200 Number 1 and Number 2 OE pin	Lo	-		DLPA200 Number 1 / Number 2 Output Enable
DDC_B11_VRN	L23	-	REFERENCE	51.1 Ω pullup to 2.5 V	-	-		Reference Voltage
DDC_B11_VRP	L22	-	REFERENCE	51.1 Ω pulldown to ground	-	-		Reference Ground
DDC_B12_VRN	M5	-	REFERENCE	51.1 Ω pullup to 2.5 V	-	-		Reference Voltage
DDC_B12_VRP	M6	-	REFERENCE	51.1 Ω pulldown to ground	-	-		Reference Ground
DDC_B15_VRN	D23	-	REFERENCE	51.1 Ω pullup to 2.5 V	-	-		Reference Voltage
DDC_B15_VRP	C22	-	REFERENCE	51.1 Ω pulldown to ground	-	-		Reference Ground
DDC_B16_VRN	A4	-	REFERENCE	51.1 Ω pullup to 2.5 V	-	-		Reference Voltage
DDC_B16_VRP	A5	-	REFERENCE	51.1 Ω pulldown to ground	-	-		Reference Ground
DDC_DCLK_A_DPN	B21	I	LVDS_25	100 Ω across pair (not terminated in the DLPC410)	-	-		Bank A Input Clock (Neg)
DDC_DCLK_A_DPP	C21	I	LVDS_25_I		-	-		Bank A Input Clock (Pos)
DDC_DCLK_B_DPN	A7	I	LVDS_25	100 Ω across pair (not terminated in the DLPC410)	-	-		Bank B Input Clock (Neg)
DDC_DCLK_B_DPP	B7	I	LVDS_25_I		-	-		Bank B Input Clock (Pos)
DDC_DCLK_C_DPN	K20	I	LVDS_25	100 Ω across pair (not terminated in the DLPC410)	-	-		Bank C Input Clock (Neg)
DDC_DCLK_C_DPP	K21	I	LVDS_25_I		-	-		Bank C Input Clock (Pos)
DDC_DCLK_D_DPN	L5	I	LVDS_25	100 Ω across pair (not terminated in the DLPC410)	-	-		Bank D Input Clock (Neg)
DDC_DCLK_D_DPP	K5	I	LVDS_25_I		-	-		Bank D Input Clock (Pos)
DDC_DCLKOUT_A_DPN	N1	O	LVDS_25	Pair connected to DMD (LVDS terminated internally in DMD - 100 Ω)	-	-		Bank A Output Clock (Neg)
DDC_DCLKOUT_A_DPP	M1	O	LVDS_25_O		-	-		Bank A Output Clock (Pos)
DDC_DCLKOUT_B_DPN	Y5	O	LVDS_25	Pair connected to DMD (LVDS terminated internally in DMD - 100 Ω)	-	-		Bank B Output Clock (Neg)
DDC_DCLKOUT_B_DPP	Y6	O	LVDS_25_O		-	-		Bank B Output Clock (Pos)
DDC_DCLKOUT_C_DPN	AA22	O	LVDS_25	Pair connected to DMD (LVDS terminated internally in DMD - 100 Ω)	-	-		Bank C Output Clock (Neg)
DDC_DCLKOUT_C_DPP	AB22	O	LVDS_25_O		-	-		Bank C Output Clock (Pos)
DDC_DCLKOUT_D_DPN	M26	O	LVDS_25	Pair connected to DMD (LVDS terminated internally in DMD - 100 Ω)	-	-		Bank D Output Clock (Neg)
DDC_DCLKOUT_D_DPP	M25	O	LVDS_25_O		-	-		Bank D Output Clock (Pos)
DDC_DIN_A0_DPN	A15	I	LVDS_25	100 Ω across pair (not terminated in the DLPC410)	-	DDC_DCLK_A	DDR	Data A bit 0 Input (Neg)
DDC_DIN_A0_DPP	A14	I	LVDS_25_I		-	DDC_DCLK_A	DDR	Data A bit 0 Input (Pos)
DDC_DIN_A1_DPN	B14	I	LVDS_25	100 Ω across pair (not terminated in the DLPC410)	-	DDC_DCLK_A	DDR	Data A bit 1 Input (Neg)
DDC_DIN_A1_DPP	C14	I	LVDS_25_I		-	DDC_DCLK_A	DDR	Data A bit 1 Input (Pos)
DDC_DIN_A2_DPN	B16	I	LVDS_25	100 Ω across pair (not terminated in the DLPC410)	-	DDC_DCLK_A	DDR	Data A bit 2 Input (Neg)
DDC_DIN_A2_DPP	B15	I	LVDS_25_I		-	DDC_DCLK_A	DDR	Data A bit 2 Input (Pos)
DDC_DIN_A3_DPN	C16	I	LVDS_25	100 Ω across pair (not terminated in the DLPC410)	-	DDC_DCLK_A	DDR	Data A bit 3 Input (Neg)
DDC_DIN_A3_DPP	D16	I	LVDS_25_I		-	DDC_DCLK_A	DDR	Data A bit 3 Input (Pos)
DDC_DIN_A4_DPN	A17	I	LVDS_25	100 Ω across pair (not terminated in the DLPC410)	-	DDC_DCLK_A	DDR	Data A bit 4 Input (Neg)
DDC_DIN_A4_DPP	B17	I	LVDS_25_I		-	DDC_DCLK_A	DDR	Data A bit 4 Input (Pos)
DDC_DIN_A5_DPN	C17	I	LVDS_25	100 Ω across pair (not terminated in the DLPC410)	-	DDC_DCLK_A	DDR	Data A bit 5 Input (Neg)
DDC_DIN_A5_DPP	D18	I	LVDS_25_I		-	DDC_DCLK_A	DDR	Data A bit 5 Input (Pos)
DDC_DIN_A6_DPN	A19	I	LVDS_25	100 Ω across pair (not terminated in the DLPC410)	-	DDC_DCLK_A	DDR	Data A bit 6 Input (Neg)
DDC_DIN_A6_DPP	A18	I	LVDS_25_I		-	DDC_DCLK_A	DDR	Data A bit 6 Input (Pos)
DDC_DIN_A7_DPN	C18	I	LVDS_25	100 Ω across pair (not terminated in the DLPC410)	-	DDC_DCLK_A	DDR	Data A bit 7 Input (Neg)
DDC_DIN_A7_DPP	B19	I	LVDS_25_I		-	DDC_DCLK_A	DDR	Data A bit 7 Input (Pos)
DDC_DIN_A8_DPN	D19	I	LVDS_25	100 Ω across pair (not terminated in the DLPC410)	-	DDC_DCLK_A	DDR	Data A bit 8 Input (Neg)
DDC_DIN_A8_DPP	C19	I	LVDS_25_I		-	DDC_DCLK_A	DDR	Data A bit 8 Input (Pos)
DDC_DIN_A9_DPN	B20	I	LVDS_25	100 Ω across pair (not terminated in the DLPC410)	-	DDC_DCLK_A	DDR	Data A bit 9 Input (Neg)
DDC_DIN_A9_DPP	A20	I	LVDS_25_I		-	DDC_DCLK_A	DDR	Data A bit 9 Input (Pos)
DDC_DIN_A10_DPN	A22	I	LVDS_25	100 Ω across pair (not terminated in the DLPC410)	-	DDC_DCLK_A	DDR	Data A bit 10 Input (Neg)
DDC_DIN_A10_DPP	B22	I	LVDS_25_I		-	DDC_DCLK_A	DDR	Data A bit 10 Input (Pos)
DDC_DIN_A11_DPN	A24	I	LVDS_25	100 Ω across pair (not terminated in the DLPC410)	-	DDC_DCLK_A	DDR	Data A bit 11 Input (Neg)
DDC_DIN_A11_DPP	A23	I	LVDS_25_I		-	DDC_DCLK_A	DDR	Data A bit 11 Input (Pos)

Pin Functions (continued)

PIN		TYPE	SIGNAL	TERMINATION /NOTES	ACTIVE (Hi or Lo)	CLOCK	DATA RATE	DESCRIPTION
NAME	NO.							
DDC_DIN_A12_DPN	C23	I	LVDS_25	100 Ω across pair (not terminated in the DLPC410)	-	DDC_DCLK_A	DDR	Data A bit 12 Input (Neg)
DDC_DIN_A12_DPP	B24	I	LVDS_25_I		-	DDC_DCLK_A	DDR	Data A bit 12 Input (Pos)
DDC_DIN_A13_DPN	C24	I	LVDS_25	100 Ω across pair (not terminated in the DLPC410)	-	DDC_DCLK_A	DDR	Data A bit 13 Input (Neg)
DDC_DIN_A13_DPP	D24	I	LVDS_25_I		-	DDC_DCLK_A	DDR	Data A bit 13 Input (Pos)
DDC_DIN_A14_DPN	A25	I	LVDS_25	100 Ω across pair (not terminated in the DLPC410)	-	DDC_DCLK_A	DDR	Data A bit 14 Input (Neg)
DDC_DIN_A14_DPP	B25	I	LVDS_25_I		-	DDC_DCLK_A	DDR	Data A bit 14 Input (Pos)
DDC_DIN_A15_DPN	C26	I	LVDS_25	100 Ω across pair (not terminated in the DLPC410)	-	DDC_DCLK_A	DDR	Data A bit 15 Input (Neg)
DDC_DIN_A15_DPP	B26	I	LVDS_25_I		-	DDC_DCLK_A	DDR	Data A bit 15 Input (Pos)
DDC_DIN_B0_DPN	A12	I	LVDS_25	100 Ω across pair (not terminated in the DLPC410)	-	DDC_DCLK_B	DDR	Data B bit 0 Input (Neg)
DDC_DIN_B0_DPP	A13	I	LVDS_25_I		-	DDC_DCLK_B	DDR	Data B bit 0 Input (Pos)
DDC_DIN_B1_DPN	B12	I	LVDS_25	100 Ω across pair (not terminated in the DLPC410)	-	DDC_DCLK_B	DDR	Data B bit 1 Input (Neg)
DDC_DIN_B1_DPP	C13	I	LVDS_25_I		-	DDC_DCLK_B	DDR	Data B bit 1 Input (Pos)
DDC_DIN_B2_DPN	D10	I	LVDS_25	100 Ω across pair (not terminated in the DLPC410)	-	DDC_DCLK_B	DDR	Data B bit 2 Input (Neg)
DDC_DIN_B2_DPP	D11	I	LVDS_25_I		-	DDC_DCLK_B	DDR	Data B bit 2 Input (Pos)
DDC_DIN_B3_DPN	C12	I	LVDS_25	100 Ω across pair (not terminated in the DLPC410)	-	DDC_DCLK_B	DDR	Data B bit 3 Input (Neg)
DDC_DIN_B3_DPP	C11	I	LVDS_25_I		-	DDC_DCLK_B	DDR	Data B bit 3 Input (Pos)
DDC_DIN_B4_DPN	A10	I	LVDS_25	100 Ω across pair (not terminated in the DLPC410)	-	DDC_DCLK_B	DDR	Data B bit 4 Input (Neg)
DDC_DIN_B4_DPP	B11	I	LVDS_25_I		-	DDC_DCLK_B	DDR	Data B bit 4 Input (Pos)
DDC_DIN_B5_DPN	D9	I	LVDS_25	100 Ω across pair (not terminated in the DLPC410)	-	DDC_DCLK_B	DDR	Data B bit 5 Input (Neg)
DDC_DIN_B5_DPP	C9	I	LVDS_25_I		-	DDC_DCLK_B	DDR	Data B bit 5 Input (Pos)
DDC_DIN_B6_DPN	B10	I	LVDS_25	100 Ω across pair (not terminated in the DLPC410)	-	DDC_DCLK_B	DDR	Data B bit 6 Input (Neg)
DDC_DIN_B6_DPP	B9	I	LVDS_25_I		-	DDC_DCLK_B	DDR	Data B bit 6 Input (Pos)
DDC_DIN_B7_DPN	A8	I	LVDS_25	100 Ω across pair (not terminated in the DLPC410)	-	DDC_DCLK_B	DDR	Data B bit 7 Input (Neg)
DDC_DIN_B7_DPP	A9	I	LVDS_25_I		-	DDC_DCLK_B	DDR	Data B bit 7 Input (Pos)
DDC_DIN_B8_DPN	D6	I	LVDS_25	100 Ω across pair (not terminated in the DLPC410)	-	DDC_DCLK_B	DDR	Data B bit 8 Input (Neg)
DDC_DIN_B8_DPP	D5	I	LVDS_25_I		-	DDC_DCLK_B	DDR	Data B bit 8 Input (Pos)
DDC_DIN_B9_DPN	C7	I	LVDS_25	100 Ω across pair (not terminated in the DLPC410)	-	DDC_DCLK_B	DDR	Data B bit 9 Input (Neg)
DDC_DIN_B9_DPP	C6	I	LVDS_25_I		-	DDC_DCLK_B	DDR	Data B bit 9 Input (Pos)
DDC_DIN_B10_DPN	B6	I	LVDS_25	100 Ω across pair (not terminated in the DLPC410)	-	DDC_DCLK_B	DDR	Data B bit 10 Input (Neg)
DDC_DIN_B10_DPP	B5	I	LVDS_25_I		-	DDC_DCLK_B	DDR	Data B bit 10 Input (Pos)
DDC_DIN_B11_DPN	D4	I	LVDS_25	100 Ω across pair (not terminated in the DLPC410)	-	DDC_DCLK_B	DDR	Data B bit 11 Input (Neg)
DDC_DIN_B11_DPP	D3	I	LVDS_25_I		-	DDC_DCLK_B	DDR	Data B bit 11 Input (Pos)
DDC_DIN_B12_DPN	B4	I	LVDS_25	100 Ω across pair (not terminated in the DLPC410)	-	DDC_DCLK_B	DDR	Data B bit 12 Input (Neg)
DDC_DIN_B12_DPP	C4	I	LVDS_25_I		-	DDC_DCLK_B	DDR	Data B bit 12 Input (Pos)
DDC_DIN_B13_DPN	C3	I	LVDS_25	100 Ω across pair (not terminated in the DLPC410)	-	DDC_DCLK_B	DDR	Data B bit 13 Input (Neg)
DDC_DIN_B13_DPP	C2	I	LVDS_25_I		-	DDC_DCLK_B	DDR	Data B bit 13 Input (Pos)
DDC_DIN_B14_DPN	A3	I	LVDS_25	100 Ω across pair (not terminated in the DLPC410)	-	DDC_DCLK_B	DDR	Data B bit 14 Input (Neg)
DDC_DIN_B14_DPP	A2	I	LVDS_25_I		-	DDC_DCLK_B	DDR	Data B bit 14 Input (Pos)
DDC_DIN_B15_DPN	B2	I	LVDS_25	100 Ω across pair (not terminated in the DLPC410)	-	DDC_DCLK_B	DDR	Data B bit 15 Input (Neg)
DDC_DIN_B15_DPP	B1	I	LVDS_25_I		-	DDC_DCLK_B	DDR	Data B bit 15 Input (Pos)
DDC_DIN_C0_DPN	E20	I	LVDS_25	100 Ω across pair (not terminated in the DLPC410)	-	DDC_DCLK_C	DDR	Data C bit 0 Input (Neg)
DDC_DIN_C0_DPP	E21	I	LVDS_25_I		-	DDC_DCLK_C	DDR	Data C bit 0 Input (Pos)
DDC_DIN_C1_DPN	F20	I	LVDS_25	100 Ω across pair (not terminated in the DLPC410)	-	DDC_DCLK_C	DDR	Data C bit 1 Input (Neg)
DDC_DIN_C1_DPP	G20	I	LVDS_25_I		-	DDC_DCLK_C	DDR	Data C bit 1 Input (Pos)
DDC_DIN_C2_DPN	H19	I	LVDS_25	100 Ω across pair (not terminated in the DLPC410)	-	DDC_DCLK_C	DDR	Data C bit 2 Input (Neg)
DDC_DIN_C2_DPP	J19	I	LVDS_25_I		-	DDC_DCLK_C	DDR	Data C bit 2 Input (Pos)
DDC_DIN_C3_DPN	E23	I	LVDS_25	100 Ω across pair (not terminated in the DLPC410)	-	DDC_DCLK_C	DDR	Data C bit 3 Input (Neg)
DDC_DIN_C3_DPP	E22	I	LVDS_25_I		-	DDC_DCLK_C	DDR	Data C bit 3 Input (Pos)
DDC_DIN_C4_DPN	F23	I	LVDS_25	100 Ω across pair (not terminated in the DLPC410)	-	DDC_DCLK_C	DDR	Data C bit 4 Input (Neg)
DDC_DIN_C4_DPP	F22	I	LVDS_25_I		-	DDC_DCLK_C	DDR	Data C bit 4 Input (Pos)
DDC_DIN_C5_DPN	G22	I	LVDS_25	100 Ω across pair (not terminated in the DLPC410)	-	DDC_DCLK_C	DDR	Data C bit 5 Input (Neg)
DDC_DIN_C5_DPP	G21	I	LVDS_25_I		-	DDC_DCLK_C	DDR	Data C bit 5 Input (Pos)
DDC_DIN_C6_DPN	J20	I	LVDS_25	100 Ω across pair (not terminated in the DLPC410)	-	DDC_DCLK_C	DDR	Data C bit 6 Input (Neg)
DDC_DIN_C6_DPP	J21	I	LVDS_25_I		-	DDC_DCLK_C	DDR	Data C bit 6 Input (Pos)

Pin Functions (continued)

PIN		TYPE	SIGNAL	TERMINATION /NOTES	ACTIVE (Hi or Lo)	CLOCK	DATA RATE	DESCRIPTION
NAME	NO.							
DDC_DIN_C7_DPN	H22	I	LVDS_25	100 Ω across pair (not terminated in the DLPC410)	-	DDC_DCLK_C	DDR	Data C bit 7 Input (Neg)
DDC_DIN_C7_DPP	H21	I	LVDS_25_I		-	DDC_DCLK_C	DDR	Data C bit 7 Input (Pos)
DDC_DIN_C8_DPN	J23	I	LVDS_25	100 Ω across pair (not terminated in the DLPC410)	-	DDC_DCLK_C	DDR	Data C bit 8 Input (Neg)
DDC_DIN_C8_DPP	H23	I	LVDS_25_I		-	DDC_DCLK_C	DDR	Data C bit 8 Input (Pos)
DDC_DIN_C9_DPN	K22	I	LVDS_25	100 Ω across pair (not terminated in the DLPC410)	-	DDC_DCLK_C	DDR	Data C bit 9 Input (Neg)
DDC_DIN_C9_DPP	K23	I	LVDS_25_I		-	DDC_DCLK_C	DDR	Data C bit 9 Input (Pos)
DDC_DIN_C10_DPN	M19	I	LVDS_25	100 Ω across pair (not terminated in the DLPC410)	-	DDC_DCLK_C	DDR	Data C bit 10 Input (Neg)
DDC_DIN_C10_DPP	M20	I	LVDS_25_I		-	DDC_DCLK_C	DDR	Data C bit 10 Input (Pos)
DDC_DIN_C11_DPN	M21	I	LVDS_25	100 Ω across pair (not terminated in the DLPC410)	-	DDC_DCLK_C	DDR	Data C bit 11 Input (Neg)
DDC_DIN_C11_DPP	M22	I	LVDS_25_I		-	DDC_DCLK_C	DDR	Data C bit 11 Input (Pos)
DDC_DIN_C12_DPN	N19	I	LVDS_25	100 Ω across pair (not terminated in the DLPC410)	-	DDC_DCLK_C	DDR	Data C bit 12 Input (Neg)
DDC_DIN_C12_DPP	P19	I	LVDS_25_I		-	DDC_DCLK_C	DDR	Data C bit 12 Input (Pos)
DDC_DIN_C13_DPN	N21	I	LVDS_25	100 Ω across pair (not terminated in the DLPC410)	-	DDC_DCLK_C	DDR	Data C bit 13 Input (Neg)
DDC_DIN_C13_DPP	N22	I	LVDS_25_I		-	DDC_DCLK_C	DDR	Data C bit 13 Input (Pos)
DDC_DIN_C14_DPN	P20	I	LVDS_25	100 Ω across pair (not terminated in the DLPC410)	-	DDC_DCLK_C	DDR	Data C bit 14 Input (Neg)
DDC_DIN_C14_DPP	P21	I	LVDS_25_I		-	DDC_DCLK_C	DDR	Data C bit 14 Input (Pos)
DDC_DIN_C15_DPN	N23	I	LVDS_25	100 Ω across pair (not terminated in the DLPC410)	-	DDC_DCLK_C	DDR	Data C bit 15 Input (Neg)
DDC_DIN_C15_DPP	P23	I	LVDS_25_I		-	DDC_DCLK_C	DDR	Data C bit 15 Input (Pos)
DDC_DIN_D0_DPN	T3	I	LVDS_25	100 Ω across pair (not terminated in the DLPC410)	-	DDC_DCLK_D	DDR	Data D bit 0 Input (Neg)
DDC_DIN_D0_DPP	R3	I	LVDS_25_I		-	DDC_DCLK_D	DDR	Data D bit 0 Input (Pos)
DDC_DIN_D1_DPN	R5	I	LVDS_25	100 Ω across pair (not terminated in the DLPC410)	-	DDC_DCLK_D	DDR	Data D bit 1 Input (Neg)
DDC_DIN_D1_DPP	R6	I	LVDS_25_I		-	DDC_DCLK_D	DDR	Data D bit 1 Input (Pos)
DDC_DIN_D2_DPN	R7	I	LVDS_25	100 Ω across pair (not terminated in the DLPC410)	-	DDC_DCLK_D	DDR	Data D bit 2 Input (Neg)
DDC_DIN_D2_DPP	P6	I	LVDS_25_I		-	DDC_DCLK_D	DDR	Data D bit 2 Input (Pos)
DDC_DIN_D3_DPN	N3	I	LVDS_25	100 Ω across pair (not terminated in the DLPC410)	-	DDC_DCLK_D	DDR	Data D bit 3 Input (Neg)
DDC_DIN_D3_DPP	P3	I	LVDS_25_I		-	DDC_DCLK_D	DDR	Data D bit 3 Input (Pos)
DDC_DIN_D4_DPN	P4	I	LVDS_25	100 Ω across pair (not terminated in the DLPC410)	-	DDC_DCLK_D	DDR	Data D bit 4 Input (Neg)
DDC_DIN_D4_DPP	P5	I	LVDS_25_I		-	DDC_DCLK_D	DDR	Data D bit 4 Input (Pos)
DDC_DIN_D5_DPN	N6	I	LVDS_25	100 Ω across pair (not terminated in the DLPC410)	-	DDC_DCLK_D	DDR	Data D bit 5 Input (Neg)
DDC_DIN_D5_DPP	N7	I	LVDS_25_I		-	DDC_DCLK_D	DDR	Data D bit 5 Input (Pos)
DDC_DIN_D6_DPN	N4	I	LVDS_25	100 Ω across pair (not terminated in the DLPC410)	-	DDC_DCLK_D	DDR	Data D bit 6 Input (Neg)
DDC_DIN_D6_DPP	M4	I	LVDS_25_I		-	DDC_DCLK_D	DDR	Data D bit 6 Input (Pos)
DDC_DIN_D7_DPN	M7	I	LVDS_25	100 Ω across pair (not terminated in the DLPC410)	-	DDC_DCLK_D	DDR	Data D bit 7 Input (Neg)
DDC_DIN_D7_DPP	L7	I	LVDS_25_I		-	DDC_DCLK_D	DDR	Data D bit 7 Input (Pos)
DDC_DIN_D8_DPN	K7	I	LVDS_25	100 Ω across pair (not terminated in the DLPC410)	-	DDC_DCLK_D	DDR	Data D bit 8 Input (Neg)
DDC_DIN_D8_DPP	K6	I	LVDS_25_I		-	DDC_DCLK_D	DDR	Data D bit 8 Input (Pos)
DDC_DIN_D9_DPN	J4	I	LVDS_25	100 Ω across pair (not terminated in the DLPC410)	-	DDC_DCLK_D	DDR	Data D bit 9 Input (Neg)
DDC_DIN_D9_DPP	J5	I	LVDS_25_I		-	DDC_DCLK_D	DDR	Data D bit 9 Input (Pos)
DDC_DIN_D10_DPN	H7	I	LVDS_25	100 Ω across pair (not terminated in the DLPC410)	-	DDC_DCLK_D	DDR	Data D bit 10 Input (Neg)
DDC_DIN_D10_DPP	J6	I	LVDS_25_I		-	DDC_DCLK_D	DDR	Data D bit 10 Input (Pos)
DDC_DIN_D11_DPN	G4	I	LVDS_25	100 Ω across pair (not terminated in the DLPC410)	-	DDC_DCLK_D	DDR	Data D bit 11 Input (Neg)
DDC_DIN_D11_DPP	H4	I	LVDS_25_I		-	DDC_DCLK_D	DDR	Data D bit 11 Input (Pos)
DDC_DIN_D12_DPN	G5	I	LVDS_25	100 Ω across pair (not terminated in the DLPC410)	-	DDC_DCLK_D	DDR	Data D bit 12 Input (Neg)
DDC_DIN_D12_DPP	H6	I	LVDS_25_I		-	DDC_DCLK_D	DDR	Data D bit 12 Input (Pos)
DDC_DIN_D13_DPN	G7	I	LVDS_25	100 Ω across pair (not terminated in the DLPC410)	-	DDC_DCLK_D	DDR	Data D bit 13 Input (Neg)
DDC_DIN_D13_DPP	G6	I	LVDS_25_I		-	DDC_DCLK_D	DDR	Data D bit 13 Input (Pos)
DDC_DIN_D14_DPN	F4	I	LVDS_25	100 Ω across pair (not terminated in the DLPC410)	-	DDC_DCLK_D	DDR	Data D bit 14 Input (Neg)
DDC_DIN_D14_DPP	F5	I	LVDS_25_I		-	DDC_DCLK_D	DDR	Data D bit 14 Input (Pos)
DDC_DIN_D15_DPN	E5	I	LVDS_25	100 Ω across pair (not terminated in the DLPC410)	-	DDC_DCLK_D	DDR	Data D bit 15 Input (Neg)
DDC_DIN_D15_DPP	E6	I	LVDS_25_I		-	DDC_DCLK_D	DDR	Data D bit 15 Input (Pos)
DDC_DOUT_A0_DPN	AE2	O	LVDS_25	Pair connected to DMD (LVDS terminated internally in DMD - 100 Ω)	-	DDC_DCLKOUT_A	DDR	Data A bit 0 Output (Neg)
DDC_DOUT_A0_DPP	AF2	O	LVDS_25_O		-	DDC_DCLKOUT_A	DDR	Data A bit 0 Output (Pos)
DDC_DOUT_A1_DPN	AD1	O	LVDS_25	Pair connected to DMD (LVDS terminated internally in DMD - 100 Ω)	-	DDC_DCLKOUT_A	DDR	Data A bit 1 Output (Neg)
DDC_DOUT_A1_DPP	AE1	O	LVDS_25_O		-	DDC_DCLKOUT_A	DDR	Data A bit 1 Output (Pos)

Pin Functions (continued)

PIN		TYPE	SIGNAL	TERMINATION /NOTES	ACTIVE (Hi or Lo)	CLOCK	DATA RATE	DESCRIPTION
NAME	NO.							
DDC_DOUT_A2_DPN	AC1	O	LVDS_25	Pair connected to DMD (LVDS terminated internally in DMD - 100 Ω)	-	DDC_DCLKOUT_A	DDR	Data A bit 2 Output (Neg)
DDC_DOUT_A2_DPP	AC2	O	LVDS_25_O		-	DDC_DCLKOUT_A	DDR	Data A bit 2 Output (Pos)
DDC_DOUT_A3_DPN	AB1	O	LVDS_25	Pair connected to DMD (LVDS terminated internally in DMD - 100 Ω)	-	DDC_DCLKOUT_A	DDR	Data A bit 3 Output (Neg)
DDC_DOUT_A3_DPP	AB2	O	LVDS_25_O		-	DDC_DCLKOUT_A	DDR	Data A bit 3 Output (Pos)
DDC_DOUT_A4_DPN	Y2	O	LVDS_25	Pair connected to DMD (LVDS terminated internally in DMD - 100 Ω)	-	DDC_DCLKOUT_A	DDR	Data A bit 4 Output (Neg)
DDC_DOUT_A4_DPP	AA2	O	LVDS_25_O		-	DDC_DCLKOUT_A	DDR	Data A bit 4 Output (Pos)
DDC_DOUT_A5_DPN	W1	O	LVDS_25	Pair connected to DMD (LVDS terminated internally in DMD - 100 Ω)	-	DDC_DCLKOUT_A	DDR	Data A bit 5 Output (Neg)
DDC_DOUT_A5_DPP	Y1	O	LVDS_25_O		-	DDC_DCLKOUT_A	DDR	Data A bit 5 Output (Pos)
DDC_DOUT_A6_DPN	V1	O	LVDS_25	Pair connected to DMD (LVDS terminated internally in DMD - 100 Ω)	-	DDC_DCLKOUT_A	DDR	Data A bit 6 Output (Neg)
DDC_DOUT_A6_DPP	V2	O	LVDS_25_O		-	DDC_DCLKOUT_A	DDR	Data A bit 6 Output (Pos)
DDC_DOUT_A7_DPN	U1	O	LVDS_25	Pair connected to DMD (LVDS terminated internally in DMD - 100 Ω)	-	DDC_DCLKOUT_A	DDR	Data A bit 7 Output (Neg)
DDC_DOUT_A7_DPP	U2	O	LVDS_25_O		-	DDC_DCLKOUT_A	DDR	Data A bit 7 Output (Pos)
DDC_DOUT_A8_DPN	R2	O	LVDS_25	Pair connected to DMD (LVDS terminated internally in DMD - 100 Ω)	-	DDC_DCLKOUT_A	DDR	Data A bit 8 Output (Neg)
DDC_DOUT_A8_DPP	T2	O	LVDS_25_O		-	DDC_DCLKOUT_A	DDR	Data A bit 8 Output (Pos)
DDC_DOUT_A9_DPN	N2	O	LVDS_25	Pair connected to DMD (LVDS terminated internally in DMD - 100 Ω)	-	DDC_DCLKOUT_A	DDR	Data A bit 9 Output (Neg)
DDC_DOUT_A9_DPP	M2	O	LVDS_25_O		-	DDC_DCLKOUT_A	DDR	Data A bit 9 Output (Pos)
DDC_DOUT_A10_DPN	K1	O	LVDS_25	Pair connected to DMD (LVDS terminated internally in DMD - 100 Ω)	-	DDC_DCLKOUT_A	DDR	Data A bit 10 Output (Neg)
DDC_DOUT_A10_DPP	L2	O	LVDS_25_O		-	DDC_DCLKOUT_A	DDR	Data A bit 10 Output (Pos)
DDC_DOUT_A11_DPN	K2	O	LVDS_25	Pair connected to DMD (LVDS terminated internally in DMD - 100 Ω)	-	DDC_DCLKOUT_A	DDR	Data A bit 11 Output (Neg)
DDC_DOUT_A11_DPP	K3	O	LVDS_25_O		-	DDC_DCLKOUT_A	DDR	Data A bit 11 Output (Pos)
DDC_DOUT_A12_DPN	J3	O	LVDS_25	Pair connected to DMD (LVDS terminated internally in DMD - 100 Ω)	-	DDC_DCLKOUT_A	DDR	Data A bit 12 Output (Neg)
DDC_DOUT_A12_DPP	H3	O	LVDS_25_O		-	DDC_DCLKOUT_A	DDR	Data A bit 12 Output (Pos)
DDC_DOUT_A13_DPN	H2	O	LVDS_25	Pair connected to DMD (LVDS terminated internally in DMD - 100 Ω)	-	DDC_DCLKOUT_A	DDR	Data A bit 13 Output (Neg)
DDC_DOUT_A13_DPP	J1	O	LVDS_25_O		-	DDC_DCLKOUT_A	DDR	Data A bit 13 Output (Pos)
DDC_DOUT_A14_DPN	H1	O	LVDS_25	Pair connected to DMD (LVDS terminated internally in DMD - 100 Ω)	-	DDC_DCLKOUT_A	DDR	Data A bit 14 Output (Neg)
DDC_DOUT_A14_DPP	G1	O	LVDS_25_O		-	DDC_DCLKOUT_A	DDR	Data A bit 14 Output (Pos)
DDC_DOUT_A15_DPN	G2	O	LVDS_25	Pair connected to DMD (LVDS terminated internally in DMD - 100 Ω)	-	DDC_DCLKOUT_A	DDR	Data A bit 15 Output (Neg)
DDC_DOUT_A15_DPP	F2	O	LVDS_25_O		-	DDC_DCLKOUT_A	DDR	Data A bit 15 Output (Pos)
DDC_DOUT_B0_DPN	AE5	O	LVDS_25	Pair connected to DMD (LVDS terminated internally in DMD - 100 Ω)	-	DDC_DCLKOUT_B	DDR	Data B bit 0 Output (Neg)
DDC_DOUT_B0_DPP	AE6	O	LVDS_25_O		-	DDC_DCLKOUT_B	DDR	Data B bit 0 Output (Pos)
DDC_DOUT_B1_DPN	AD3	O	LVDS_25	Pair connected to DMD (LVDS terminated internally in DMD - 100 Ω)	-	DDC_DCLKOUT_B	DDR	Data B bit 1 Output (Neg)
DDC_DOUT_B1_DPP	AD4	O	LVDS_25_O		-	DDC_DCLKOUT_B	DDR	Data B bit 1 Output (Pos)
DDC_DOUT_B2_DPN	AD5	O	LVDS_25	Pair connected to DMD (LVDS terminated internally in DMD - 100 Ω)	-	DDC_DCLKOUT_B	DDR	Data B bit 2 Output (Neg)
DDC_DOUT_B2_DPP	AD6	O	LVDS_25_O		-	DDC_DCLKOUT_B	DDR	Data B bit 2 Output (Pos)
DDC_DOUT_B3_DPN	AC3	O	LVDS_25	Pair connected to DMD (LVDS terminated internally in DMD - 100 Ω)	-	DDC_DCLKOUT_B	DDR	Data B bit 3 Output (Neg)
DDC_DOUT_B3_DPP	AC4	O	LVDS_25_O		-	DDC_DCLKOUT_B	DDR	Data B bit 3 Output (Pos)
DDC_DOUT_B4_DPN	AB5	O	LVDS_25	Pair connected to DMD (LVDS terminated internally in DMD - 100 Ω)	-	DDC_DCLKOUT_B	DDR	Data B bit 4 Output (Neg)
DDC_DOUT_B4_DPP	AB6	O	LVDS_25_O		-	DDC_DCLKOUT_B	DDR	Data B bit 4 Output (Pos)
DDC_DOUT_B5_DPN	AB7	O	LVDS_25	Pair connected to DMD (LVDS terminated internally in DMD - 100 Ω)	-	DDC_DCLKOUT_B	DDR	Data B bit 5 Output (Neg)
DDC_DOUT_B5_DPP	AC6	O	LVDS_25_O		-	DDC_DCLKOUT_B	DDR	Data B bit 5 Output (Pos)
DDC_DOUT_B6_DPN	AA5	O	LVDS_25	Pair connected to DMD (LVDS terminated internally in DMD - 100 Ω)	-	DDC_DCLKOUT_B	DDR	Data B bit 6 Output (Neg)
DDC_DOUT_B6_DPP	AA4	O	LVDS_25_O		-	DDC_DCLKOUT_B	DDR	Data B bit 6 Output (Pos)
DDC_DOUT_B7_DPN	AA7	O	LVDS_25	Pair connected to DMD (LVDS terminated internally in DMD - 100 Ω)	-	DDC_DCLKOUT_B	DDR	Data B bit 7 Output (Neg)
DDC_DOUT_B7_DPP	Y7	O	LVDS_25_O		-	DDC_DCLKOUT_B	DDR	Data B bit 7 Output (Pos)
DDC_DOUT_B8_DPN	Y3	O	LVDS_25	Pair connected to DMD (LVDS terminated internally in DMD - 100 Ω)	-	DDC_DCLKOUT_B	DDR	Data B bit 8 Output (Neg)
DDC_DOUT_B8_DPP	W3	O	LVDS_25_O		-	DDC_DCLKOUT_B	DDR	Data B bit 8 Output (Pos)
DDC_DOUT_B9_DPN	W4	O	LVDS_25	Pair connected to DMD (LVDS terminated internally in DMD - 100 Ω)	-	DDC_DCLKOUT_B	DDR	Data B bit 9 Output (Neg)
DDC_DOUT_B9_DPP	V4	O	LVDS_25_O		-	DDC_DCLKOUT_B	DDR	Data B bit 9 Output (Pos)

Pin Functions (continued)

PIN		TYPE	SIGNAL	TERMINATION /NOTES	ACTIVE (Hi or Lo)	CLOCK	DATA RATE	DESCRIPTION
NAME	NO.							
DDC_DOUT_B10_DPN	W6	O	LVDS_25	Pair connected to DMD (LVDS terminated internally in DMD - 100 Ω)	-	DDC_DCLKOUT_B	DDR	Data B bit 10 Output (Neg)
DDC_DOUT_B10_DPP	W5	O	LVDS_25_O		-	DDC_DCLKOUT_B	DDR	Data B bit 10 Output (Pos)
DDC_DOUT_B11_DPN	V7	O	LVDS_25	Pair connected to DMD (LVDS terminated internally in DMD - 100 Ω)	-	DDC_DCLKOUT_B	DDR	Data B bit 11 Output (Neg)
DDC_DOUT_B11_DPP	V6	O	LVDS_25_O		-	DDC_DCLKOUT_B	DDR	Data B bit 11 Output (Pos)
DDC_DOUT_B12_DPN	U4	O	LVDS_25	Pair connected to DMD (LVDS terminated internally in DMD - 100 Ω)	-	DDC_DCLKOUT_B	DDR	Data B bit 12 Output (Neg)
DDC_DOUT_B12_DPP	V3	O	LVDS_25_O		-	DDC_DCLKOUT_B	DDR	Data B bit 12 Output (Pos)
DDC_DOUT_B13_DPN	T4	O	LVDS_25	Pair connected to DMD (LVDS terminated internally in DMD - 100 Ω)	-	DDC_DCLKOUT_B	DDR	Data B bit 13 Output (Neg)
DDC_DOUT_B13_DPP	T5	O	LVDS_25_O		-	DDC_DCLKOUT_B	DDR	Data B bit 13 Output (Pos)
DDC_DOUT_B14_DPN	U6	O	LVDS_25	Pair connected to DMD (LVDS terminated internally in DMD - 100 Ω)	-	DDC_DCLKOUT_B	DDR	Data B bit 14 Output (Neg)
DDC_DOUT_B14_DPP	U5	O	LVDS_25_O		-	DDC_DCLKOUT_B	DDR	Data B bit 14 Output (Pos)
DDC_DOUT_B15_DPN	U7	O	LVDS_25	Pair connected to DMD (LVDS terminated internally in DMD - 100 Ω)	-	DDC_DCLKOUT_B	DDR	Data B bit 15 Output (Neg)
DDC_DOUT_B15_DPP	T7	O	LVDS_25_O		-	DDC_DCLKOUT_B	DDR	Data B bit 15 Output (Pos)
DDC_DOUT_C0_DPN	T22	O	LVDS_25	Pair connected to DMD (LVDS terminated internally in DMD - 100 Ω)	-	DDC_DCLKOUT_C	DDR	Data C bit 0 Output (Neg)
DDC_DOUT_C0_DPP	T23	O	LVDS_25_O		-	DDC_DCLKOUT_C	DDR	Data C bit 0 Output (Pos)
DDC_DOUT_C1_DPN	R20	O	LVDS_25	Pair connected to DMD (LVDS terminated internally in DMD - 100 Ω)	-	DDC_DCLKOUT_C	DDR	Data C bit 1 Output (Neg)
DDC_DOUT_C1_DPP	R21	O	LVDS_25_O		-	DDC_DCLKOUT_C	DDR	Data C bit 1 Output (Pos)
DDC_DOUT_C2_DPN	T19	O	LVDS_25	Pair connected to DMD (LVDS terminated internally in DMD - 100 Ω)	-	DDC_DCLKOUT_C	DDR	Data C bit 2 Output (Neg)
DDC_DOUT_C2_DPP	T20	O	LVDS_25_O		-	DDC_DCLKOUT_C	DDR	Data C bit 2 Output (Pos)
DDC_DOUT_C3_DPN	U21	O	LVDS_25	Pair connected to DMD (LVDS terminated internally in DMD - 100 Ω)	-	DDC_DCLKOUT_C	DDR	Data C bit 3 Output (Neg)
DDC_DOUT_C3_DPP	U22	O	LVDS_25_O		-	DDC_DCLKOUT_C	DDR	Data C bit 3 Output (Pos)
DDC_DOUT_C4_DPN	U20	O	LVDS_25	Pair connected to DMD (LVDS terminated internally in DMD - 100 Ω)	-	DDC_DCLKOUT_C	DDR	Data C bit 4 Output (Neg)
DDC_DOUT_C4_DPP	U19	O	LVDS_25_O		-	DDC_DCLKOUT_C	DDR	Data C bit 4 Output (Pos)
DDC_DOUT_C5_DPN	V23	O	LVDS_25	Pair connected to DMD (LVDS terminated internally in DMD - 100 Ω)	-	DDC_DCLKOUT_C	DDR	Data C bit 5 Output (Neg)
DDC_DOUT_C5_DPP	V24	O	LVDS_25_O		-	DDC_DCLKOUT_C	DDR	Data C bit 5 Output (Pos)
DDC_DOUT_C6_DPN	V22	O	LVDS_25	Pair connected to DMD (LVDS terminated internally in DMD - 100 Ω)	-	DDC_DCLKOUT_C	DDR	Data C bit 6 Output (Neg)
DDC_DOUT_C6_DPP	V21	O	LVDS_25_O		-	DDC_DCLKOUT_C	DDR	Data C bit 6 Output (Pos)
DDC_DOUT_C7_DPN	W19	O	LVDS_25	Pair connected to DMD (LVDS terminated internally in DMD - 100 Ω)	-	DDC_DCLKOUT_C	DDR	Data C bit 7 Output (Neg)
DDC_DOUT_C7_DPP	V19	O	LVDS_25_O		-	DDC_DCLKOUT_C	DDR	Data C bit 7 Output (Pos)
DDC_DOUT_C8_DPN	W23	O	LVDS_25	Pair connected to DMD (LVDS terminated internally in DMD - 100 Ω)	-	DDC_DCLKOUT_C	DDR	Data C bit 8 Output (Neg)
DDC_DOUT_C8_DPP	W24	O	LVDS_25_O		-	DDC_DCLKOUT_C	DDR	Data C bit 8 Output (Pos)
DDC_DOUT_C9_DPN	Y22	O	LVDS_25	Pair connected to DMD (LVDS terminated internally in DMD - 100 Ω)	-	DDC_DCLKOUT_C	DDR	Data C bit 9 Output (Neg)
DDC_DOUT_C9_DPP	Y23	O	LVDS_25_O		-	DDC_DCLKOUT_C	DDR	Data C bit 9 Output (Pos)
DDC_DOUT_C10_DPN	Y20	O	LVDS_25	Pair connected to DMD (LVDS terminated internally in DMD - 100 Ω)	-	DDC_DCLKOUT_C	DDR	Data C bit 10 Output (Neg)
DDC_DOUT_C10_DPP	Y21	O	LVDS_25_O		-	DDC_DCLKOUT_C	DDR	Data C bit 10 Output (Pos)
DDC_DOUT_C11_DPN	AA24	O	LVDS_25	Pair connected to DMD (LVDS terminated internally in DMD - 100 Ω)	-	DDC_DCLKOUT_C	DDR	Data C bit 11 Output (Neg)
DDC_DOUT_C11_DPP	AA23	O	LVDS_25_O		-	DDC_DCLKOUT_C	DDR	Data C bit 11 Output (Pos)
DDC_DOUT_C12_DPN	AA19	O	LVDS_25	Pair connected to DMD (LVDS terminated internally in DMD - 100 Ω)	-	DDC_DCLKOUT_C	DDR	Data C bit 12 Output (Neg)
DDC_DOUT_C12_DPP	AA20	O	LVDS_25_O		-	DDC_DCLKOUT_C	DDR	Data C bit 12 Output (Pos)
DDC_DOUT_C13_DPN	AC24	O	LVDS_25	Pair connected to DMD (LVDS terminated internally in DMD - 100 Ω)	-	DDC_DCLKOUT_C	DDR	Data C bit 13 Output (Neg)
DDC_DOUT_C13_DPP	AB24	O	LVDS_25_O		-	DDC_DCLKOUT_C	DDR	Data C bit 13 Output (Pos)
DDC_DOUT_C14_DPN	AC19	O	LVDS_25	Pair connected to DMD (LVDS terminated internally in DMD - 100 Ω)	-	DDC_DCLKOUT_C	DDR	Data C bit 14 Output (Neg)
DDC_DOUT_C14_DPP	AD19	O	LVDS_25_O		-	DDC_DCLKOUT_C	DDR	Data C bit 14 Output (Pos)
DDC_DOUT_C15_DPN	AC22	O	LVDS_25	Pair connected to DMD (LVDS terminated internally in DMD - 100 Ω)	-	DDC_DCLKOUT_C	DDR	Data C bit 15 Output (Neg)
DDC_DOUT_C15_DPP	AC23	O	LVDS_25_O		-	DDC_DCLKOUT_C	DDR	Data C bit 15 Output (Pos)
DDC_DOUT_D0_DPN	AB26	O	LVDS_25	Pair connected to DMD (LVDS terminated internally in DMD - 100 Ω)	-	DDC_DCLKOUT_D	DDR	Data D bit 0 Output (Neg)
DDC_DOUT_D0_DPP	AC26	O	LVDS_25_O		-	DDC_DCLKOUT_D	DDR	Data D bit 0 Output (Pos)
DDC_DOUT_D1_DPN	AA25	O	LVDS_25	Pair connected to DMD (LVDS terminated internally in DMD - 100 Ω)	-	DDC_DCLKOUT_D	DDR	Data D bit 1 Output (Neg)
DDC_DOUT_D1_DPP	AB25	O	LVDS_25_O		-	DDC_DCLKOUT_D	DDR	Data D bit 1 Output (Pos)

Pin Functions (continued)

PIN		TYPE	SIGNAL	TERMINATION /NOTES	ACTIVE (Hi or Lo)	CLOCK	DATA RATE	DESCRIPTION
NAME	NO.							
DDC_DOUT_D2_DPN	Y26	O	LVDS_25	Pair connected to DMD (LVDS terminated internally in DMD - 100 Ω)	-	DDC_DCLKOUT_D	DDR	Data D bit 2 Output (Neg)
DDC_DOUT_D2_DPP	Y25	O	LVDS_25_O		-	DDC_DCLKOUT_D	DDR	Data D bit 2 Output (Pos)
DDC_DOUT_D3_DPN	W26	O	LVDS_25	Pair connected to DMD (LVDS terminated internally in DMD - 100 Ω)	-	DDC_DCLKOUT_D	DDR	Data D bit 3 Output (Neg)
DDC_DOUT_D3_DPP	W25	O	LVDS_25_O		-	DDC_DCLKOUT_D	DDR	Data D bit 3 Output (Pos)
DDC_DOUT_D4_DPN	U26	O	LVDS_25	Pair connected to DMD (LVDS terminated internally in DMD - 100 Ω)	-	DDC_DCLKOUT_D	DDR	Data D bit 4 Output (Neg)
DDC_DOUT_D4_DPP	V26	O	LVDS_25_O		-	DDC_DCLKOUT_D	DDR	Data D bit 4 Output (Pos)
DDC_DOUT_D5_DPN	U25	O	LVDS_25	Pair connected to DMD (LVDS terminated internally in DMD - 100 Ω)	-	DDC_DCLKOUT_D	DDR	Data D bit 5 Output (Neg)
DDC_DOUT_D5_DPP	U24	O	LVDS_25_O		-	DDC_DCLKOUT_D	DDR	Data D bit 5 Output (Pos)
DDC_DOUT_D6_DPN	T25	O	LVDS_25	Pair connected to DMD (LVDS terminated internally in DMD - 100 Ω)	-	DDC_DCLKOUT_D	DDR	Data D bit 6 Output (Neg)
DDC_DOUT_D6_DPP	T24	O	LVDS_25_O		-	DDC_DCLKOUT_D	DDR	Data D bit 6 Output (Pos)
DDC_DOUT_D7_DPN	R26	O	LVDS_25	Pair connected to DMD (LVDS terminated internally in DMD - 100 Ω)	-	DDC_DCLKOUT_D	DDR	Data D bit 7 Output (Neg)
DDC_DOUT_D7_DPP	R25	O	LVDS_25_O		-	DDC_DCLKOUT_D	DDR	Data D bit 7 Output (Pos)
DDC_DOUT_D8_DPN	P24	O	LVDS_25	Pair connected to DMD (LVDS terminated internally in DMD - 100 Ω)	-	DDC_DCLKOUT_D	DDR	Data D bit 8 Output (Neg)
DDC_DOUT_D8_DPP	P25	O	LVDS_25_O		-	DDC_DCLKOUT_D	DDR	Data D bit 8 Output (Pos)
DDC_DOUT_D9_DPN	N24	O	LVDS_25	Pair connected to DMD (LVDS terminated internally in DMD - 100 Ω)	-	DDC_DCLKOUT_D	DDR	Data D bit 9 Output (Neg)
DDC_DOUT_D9_DPP	M24	O	LVDS_25_O		-	DDC_DCLKOUT_D	DDR	Data D bit 9 Output (Pos)
DDC_DOUT_D10_DPN	L25	O	LVDS_25	Pair connected to DMD (LVDS terminated internally in DMD - 100 Ω)	-	DDC_DCLKOUT_D	DDR	Data D bit 10 Output (Neg)
DDC_DOUT_D10_DPP	L24	O	LVDS_25_O		-	DDC_DCLKOUT_D	DDR	Data D bit 10 Output (Pos)
DDC_DOUT_D11_DPN	K26	O	LVDS_25	Pair connected to DMD (LVDS terminated internally in DMD - 100 Ω)	-	DDC_DCLKOUT_D	DDR	Data D bit 11 Output (Neg)
DDC_DOUT_D11_DPP	K25	O	LVDS_25_O		-	DDC_DCLKOUT_D	DDR	Data D bit 11 Output (Pos)
DDC_DOUT_D12_DPN	J26	O	LVDS_25	Pair connected to DMD (LVDS terminated internally in DMD - 100 Ω)	-	DDC_DCLKOUT_D	DDR	Data D bit 12 Output (Neg)
DDC_DOUT_D12_DPP	J25	O	LVDS_25_O		-	DDC_DCLKOUT_D	DDR	Data D bit 12 Output (Pos)
DDC_DOUT_D13_DPN	J24	O	LVDS_25	Pair connected to DMD (LVDS terminated internally in DMD - 100 Ω)	-	DDC_DCLKOUT_D	DDR	Data D bit 13 Output (Neg)
DDC_DOUT_D13_DPP	H24	O	LVDS_25_O		-	DDC_DCLKOUT_D	DDR	Data D bit 13 Output (Pos)
DDC_DOUT_D14_DPN	H26	O	LVDS_25	Pair connected to DMD (LVDS terminated internally in DMD - 100 Ω)	-	DDC_DCLKOUT_D	DDR	Data D bit 14 Output (Neg)
DDC_DOUT_D14_DPP	G26	O	LVDS_25_O		-	DDC_DCLKOUT_D	DDR	Data D bit 14 Output (Pos)
DDC_DOUT_D15_DPN	G25	O	LVDS_25	Pair connected to DMD (LVDS terminated internally in DMD - 100 Ω)	-	DDC_DCLKOUT_D	DDR	Data D bit 15 Output (Neg)
DDC_DOUT_D15_DPP	G24	O	LVDS_25_O		-	DDC_DCLKOUT_D	DDR	Data D bit 15 Output (Pos)
DDC_M0	W18	-	NC	4.7 kΩ pullup to 2.5V	Hi	-		Xilinx Configuration
DDC_M1	Y17	-	NC	4.7 kΩ pullup to 2.5V	Hi	-		Xilinx Configuration
DDC_M2	V18	-	NC	4.7 kΩ pullup to 2.5V	Hi	-		Xilinx Configuration
DDC_SCTRL_AN	R1	O	LVDS_25	Pair connected to DMD (LVDS terminated internally in DMD - 100 Ω)	-	DDC_DCLKOUT_A	DDR	Bank A Serial Control Data (Neg)
DDC_SCTRL_AP	P1	O	LVDS_25_O		-	DDC_DCLKOUT_A	DDR	Bank A Serial Control Data (Pos)
DDC_SCTRL_BN	AA3	O	LVDS_25	Pair connected to DMD (LVDS terminated internally in DMD - 100 Ω)	-	DDC_DCLKOUT_B	DDR	Bank B Serial Control Data (Neg)
DDC_SCTRL_BP	AB4	O	LVDS_25_O		-	DDC_DCLKOUT_B	DDR	Bank B Serial Control Data (Pos)
DDC_SCTRL_CN	W20	O	LVDS_25	Pair connected to DMD (LVDS terminated internally in DMD - 100 Ω)	-	DDC_DCLKOUT_C	DDR	Bank C Serial Control Data (Neg)
DDC_SCTRL_CP	W21	O	LVDS_25_O		-	DDC_DCLKOUT_C	DDR	Bank C Serial Control Data (Pos)
DDC_SCTRL_DN	N26	O	LVDS_25	Pair connected to DMD (LVDS terminated internally in DMD - 100 Ω)	-	DDC_DCLKOUT_D	DDR	Bank D Serial Control Data (Neg)
DDC_SCTRL_DP	P26	O	LVDS_25_O		-	DDC_DCLKOUT_D	DDR	Bank D Serial Control Data (Pos)
DDC_VERSION_0	F18	O	LVCN0525_F_12_O		Hi = 1	-		DLPC410 Firmware Rev Number bit 0
DDC_VERSION_1	G17	O	LVCN0525_F_12_O		Hi = 1	-		DLPC410 Firmware Rev Number bit 1
DDC_VERSION_2	H18	O	LVCN0525_F_12_O		Hi = 1	-		DLPC410 Firmware Rev Number bit 2
DDC_SPARE_1	AC21	-	LVCN0525_F_12_O	Do not connect	-	-		Not Used

Pin Functions (continued)

PIN		TYPE	SIGNAL	TERMINATION /NOTES	ACTIVE (Hi or Lo)	CLOCK	DATA RATE	DESCRIPTION
NAME	NO.							
DMD_A_RESET	AD14	O	LVCN0525_F_12_O	Connected in Reference Design to 36 Ω resistor with 27 pF cap to ground (signal name DMD_A_RESET_FILTER after resistor - connects to DMD signal DMDRST)	Lo	-		DMD Circuitry Reset (not data reset)
DMD_A_SCPEN	AB14	O	LVCN0525_F_12_O	Connected in Reference Design to 36 Ω resistor with 27 pF cap to ground (called DMD_A_SCPEN# in Reference Design- signal name DMD_A_SCPEN#_FILTER after resistor - connects to DMD signal DMDSEL)	Lo	-		DMD SCP Output Enable
DMD_B_RESET	AA12	O	LVCN0525_S_12_O	Connected in Reference Design to 36 Ω resistor with 27 pF cap to ground (signal name DMD_B_RESET_FILTER after resistor - NC after that point)	-	-		Not Used
DMD_B_SCPEN	AC14	O	LVCN0525_S_12_O	Connected in Reference Design to 36 Ω resistor with 27 pF cap to ground (called DMD_B_SCPEN# in Reference Design - signal name DMD_B_SCPEN#_FILTER after resistor - NC after that point)	-	-		Not Used
DMD_TYPE_0	AA17	O	LVCN0525_F_12_O		Hi = 1	-		DMD Attached Type bit 0
DMD_TYPE_1	AC16	O	LVCN0525_F_12_O		Hi = 1	-		DMD Attached Type bit 1
DMD_TYPE_2	AB17	O	LVCN0525_F_12_O		Hi = 1	-		DMD Attached Type bit 2
DMD_TYPE_3	AD15	O	LVCN0525_F_12_O		Hi = 1	-		DMD Attached Type bit 3
DONE_DDC	K10	O	-	4.7 kΩ pullup to 2.5V - connected to DLPR410 CE pin and LED D3 pin 3 (cathode) in series with 62 Ω resistor to 3.3 V	Hi	-		DLPR410 Initialization Routine Complete
DVALID_A_DPN	D20	I	LVDS_25	100 Ω across pair (not terminated in the DLPC410)	-	DDC_DCLK_A		Bank A Valid Input Signal (Neg)
DVALID_A_DPP	D21	I	LVDS_25_I		-	DDC_DCLK_A		Bank A Valid Input Signal (Pos)
DVALID_B_DPN	C8	I	LVDS_25	100 Ω across pair (not terminated in the DLPC410)	-	DDC_DCLK_B		Bank B Valid Input Signal (Neg)
DVALID_B_DPP	D8	I	LVDS_25_I		-	DDC_DCLK_B		Bank B Valid Input Signal (Pos)
DVALID_C_DPN	L19	I	LVDS_25	100 Ω across pair (not terminated in the DLPC410)	-	DDC_DCLK_C		Bank C Valid Input Signal (Neg)
DVALID_C_DPP	L20	I	LVDS_25_I		-	DDC_DCLK_C		Bank C Valid Input Signal (Pos)
DVALID_D_DPN	L3	I	LVDS_25	100 Ω across pair (not terminated in the DLPC410)	-	DDC_DCLK_D		Bank D Valid Input Signal (Neg)
DVALID_D_DPP	L4	I	LVDS_25_I		-	DDC_DCLK_D		Bank D Valid Input Signal (Pos)
DXN_0	R13	-	NC	TP17 in Reference Design	-	-		Dedicated Xilinx Temperature Diode (anode); Not Used in Reference Design
DXP_0	R14	-	NC	TP14 in Reference Design	-	-		Dedicated Xilinx Temperature Diode (cathode); Not Used in Reference Design
ECP2_FINISHED	Y18	O	LVCN0525_F_12_O	Connected to LED D3 pin 2 (anode) in series with 62 Ω resistor to 3.3 V	Hi	-		DLPR410 Initialization Routine Complete
ECP2_M_TP0	AD11	-	LVCN0525_F_12_O	Mictor J8 Pin 2 in Reference Design	-	-		Not Used - do not connect
ECP2_M_TP1	AD10	-	LVCN0525_F_12_O	Mictor J8 Pin 4 in Reference Design	-	-		Reserved - do not connect
ECP2_M_TP2	AD8	-	LVCN0525_F_12_O	Mictor J8 Pin 6 in Reference Design	-	-		Reserved - do not connect

Pin Functions (continued)

PIN		TYPE	SIGNAL	TERMINATION /NOTES	ACTIVE (Hi or Lo)	CLOCK	DATA RATE	DESCRIPTION
NAME	NO.							
ECP2_M_TP3	AC8	O	LVC MOS25_F_12_O	Mictor J8 Pin 8 in Reference Design	-	-		Buffered data clock - test point
ECP2_M_TP4	AC7	O	LVC MOS25_F_12_O	Mictor J8 Pin 10 in Reference Design	-	-		Reserved - do not connect
ECP2_M_TP5	AC9	O	LVC MOS25_F_12_O	Mictor J8 Pin 12 in Reference Design	Hi			Reserved - do not connect
ECP2_M_TP6	AB9	O	LVC MOS25_F_12_O	Mictor J8 Pin 14 in Reference Design	Hi			Reserved - do not connect
ECP2_M_TP7	AA8	O	LVC MOS25_F_12_O	Mictor J8 Pin 16 in Reference Design	Hi			Reserved - do not connect
ECP2_M_TP8	AA9	O	LVC MOS25_F_12_O	Mictor J8 Pin 18 in Reference Design	Hi			Reserved - do not connect
ECP2_M_TP9	Y8	O	LVC MOS25_F_12_O	Mictor J8 Pin 20 in Reference Design	-	-		Reserved - do not connect
ECP2_M_TP10	AB10	O	LVC MOS25_F_12_O	Mictor J8 Pin 22 in Reference Design	Lo			Reserved - do not connect
ECP2_M_TP11	AA10	O	LVC MOS25_F_12_O	Mictor J8 Pin 24 in Reference Design	Hi			Reserved - do not connect
ECP2_M_TP12	Y10	O	LVC MOS25_F_12_O	Mictor J8 Pin 26 in Reference Design	Hi			DMD A/B bus OK - test point
ECP2_M_TP13	AC11	O	LVC MOS25_F_12_O	Mictor J8 Pin 28 in Reference Design	Hi			DMD C/D bus OK - test point
ECP2_M_TP14	Y12	O	LVC MOS25_F_12_O	Mictor J8 Pin 30 in Reference Design	Hi			Reserved - do not connect
ECP2_M_TP15	Y11	O	LVC MOS25_F_12_O	Mictor J8 Pin 32 in Reference Design	-			Reserved - do not connect
ECP2_M_TP16	AB11	O	LVC MOS25_F_12_O	Mictor J8 Pin 34 in Reference Design	Hi			Reserved - do not connect
ECP2_M_TP17	H8	O	LVC MOS25_F_12_O	Mictor J8 Pin 36 in Reference Design	Hi			Reserved - do not connect
ECP2_M_TP18	H9	O	LVC MOS25_F_12_O	Mictor J8 Pin 38 in Reference Design	Hi			Reserved - do not connect
ECP2_M_TP19	F12	O	LVC MOS25_F_12_O	Mictor J8 Pin 37 in Reference Design	-	-		Reserved - do not connect
ECP2_M_TP20	G11	O	LVC MOS25_F_12_O	Mictor J8 Pin 35 in Reference Design	Hi			Reserved - do not connect
ECP2_M_TP21	G12	O	LVC MOS25_F_12_O	Mictor J8 Pin 33 in Reference Design	Hi			Reserved - do not connect
ECP2_M_TP22	E11	O	LVC MOS25_F_12_O	Mictor J8 Pin 31 in Reference Design	Hi			Reserved - do not connect
ECP2_M_TP23	E10	O	LVC MOS25_F_12_O	Mictor J8 Pin 29 in Reference Design	Hi			Reserved - do not connect
ECP2_M_TP24	E8	O	LVC MOS25_F_12_O	Mictor J8 Pin 27 in Reference Design	Hi			Reserved - do not connect
ECP2_M_TP25	F10	O	LVC MOS25_F_12_O	Mictor J8 Pin 25 in Reference Design	Hi			Reserved - do not connect
ECP2_M_TP26	F9	O	LVC MOS25_F_12_O	Mictor J8 Pin 23 in Reference Design	Hi			Reserved - do not connect
ECP2_M_TP27	F8	O	LVC MOS25_F_12_O	Mictor J8 Pin 21 in Reference Design	Hi			Reserved - do not connect
ECP2_M_TP28	G10	O	LVC MOS25_F_12_O	Mictor J8 Pin 19 in Reference Design	Hi			Reserved - do not connect
ECP2_M_TP29	G9	O	LVC MOS25_F_12_O	Mictor J8 Pin 17 in Reference Design	Hi			Reserved - do not connect
ECP2_M_TP30	H11	O	LVC MOS25_F_12_O	Mictor J8 Pin 15 in Reference Design	-	-		Reserved - do not connect
ECP2_M_TP31	H12	O	LVC MOS25_F_12_O	Mictor J8 Pin 13 in Reference Design	-	-		Reserved - do not connect

Pin Functions (continued)

PIN		TYPE	SIGNAL	TERMINATION /NOTES	ACTIVE (Hi or Lo)	CLOCK	DATA RATE	DESCRIPTION
NAME	NO.							
GND	A1, A6, A11, A16, A21, A26, AA1, AA11, AA21, AA26, AB8, AB18, AC5, AC15, AC25, AD2, AD12, AD22, AE4, AE9, AE14, AE19, AF1, AF6, AF11, AF16, AF21, AF26, B3, B8, B13, B18, C5, C15, C25, D2, D12, D22, E9, E19, F1, F6, F16, F26, G3, G13, G18, G23, H10, H20, J7, J9, J13, J15, J17, K4, K8, K12, K14, K16, K19, K24, L1, L9, L11, L13, L15, L17, L21, L26, M3, M8, M10, M12, M16, M18, N5, N9, N11, N15, N17, N25, P2, P7, P8, P10, P12, P16, P22, R9, R11, R15, R17, R19, T1, T6, T8, T10, T12, T14, T16, T26, U3, U9, U13, U15, U17, U18, U23, V8, V10, V14, V16, V20, W7, W9, W13, W15, W17, Y4, Y14, Y16, Y19, Y24	-	GND		-	-		Connect to Ground
HSWAPEN	L18	-	-	4.7 kΩ pullup to 2.5 V	-	-		Xilinx Configuration
INIT_ACTIVE	AA18	O	LVCNOS25_F_12_O		Hi	-		DLPC410 Initialization Routine Active
INTB_DDC	J11	-	-	4.7 kΩ pullup to 2.5 V connected to DLPR410 OE/RESET	Hi	-		Xilinx Configuration
LOAD4	AB21	-	LVCNOS25_F_12_I/O	Previously DDC_SPARE_0, connected to Applications FPGA (U5) pin AD19 in Reference Design. Weak internal pull-up. Pull-up to logic '1' if LOAD4 is unused.	-	-		LOAD4 mode enable
NS_FLIP	F19	I	LVCNOS25_S_12_I		Hi	-		Top/Bottom image flip on DMD
PROGB_DDC	J18		-	4.7 kΩ pullup to 2.5 V connected to DLPR410 CF	Hi	-		Xilinx Configuration
PROM_CCK_DDC	J10	I	LVCNOS25_S_12	Connected to center of voltage divider (100/100 Ω) and through R53 to DLPR410 CLKOUT	-	PROM_CCK_DDC		Configuration PROM Clock
PROM_D0_DDC	K11	-	-	Connected to DLPR410 Data 0 (D0)	-	PROM_CCK_DDC		Configuration PROM Data Out
PWR_FLOAT	AC17	I	LVCNOS25_S_12_I	Connected to output of U22 NOR Gate (inputs V5_PWR_FLOAT and PWRGD)	Hi	-		DMD Power Good indicator
RDWR_B	P18	-	-	1 kΩ pulldown to ground	-	-		Xilinx Configuration
ROWAD_0	D14	I	LVCNOS25_S_12_I		Hi = 1	-		DMD Row Address bit 0
ROWAD_1	D15	I	LVCNOS25_S_12_I		Hi = 1	-		DMD Row Address bit 1
ROWAD_2	E15	I	LVCNOS25_S_12_I		Hi = 1	-		DMD Row Address bit 2

Pin Functions (continued)

PIN		TYPE	SIGNAL	TERMINATION /NOTES	ACTIVE (Hi or Lo)	CLOCK	DATA RATE	DESCRIPTION
NAME	NO.							
ROWAD_3	F14	I	LVC MOS25_S_12_I		Hi = 1	-		DMD Row Address bit 3
ROWAD_4	G14	I	LVC MOS25_S_12_I		Hi = 1	-		DMD Row Address bit 4
ROWAD_5	E16	I	LVC MOS25_S_12_I		Hi = 1	-		DMD Row Address bit 5
ROWAD_6	F15	I	LVC MOS25_S_12_I		Hi = 1	-		DMD Row Address bit 6
ROWAD_7	G15	I	LVC MOS25_S_12_I		Hi = 1	-		DMD Row Address bit 7
ROWAD_8	E17	I	LVC MOS25_S_12_I		Hi = 1	-		DMD Row Address bit 8
ROWAD_9	F17	I	LVC MOS25_S_12_I		Hi = 1	-		DMD Row Address bit 9
ROWAD_10	G16	I	LVC MOS25_S_12_I		Hi = 1	-		DMD Row Address bit 10
ROWMD_0	H17	I	LVC MOS25_S_12_I		Hi = 1	-		DMD Row Mode bit 0
ROWMD_1	H16	I	LVC MOS25_S_12_I		Hi = 1	-		DMD Row Mode bit 1
RST_ACTIVE	AB16	I	LVC MOS25_F_12_O		Hi = 1	-		DMD Reset in Progress
RST2BLK	E18	I	LVC MOS25_S_12_I		Hi = 1	-		Dual Block Reset bit
RSVD_0	R18	-	-	Connect to Ground	-	-		Not Used - must be tied to Ground
RSVD_1	T18	-	-	Connect to Ground	-	-		Not Used - must be tied to Ground
SCPCLK	AB15		LVC MOS25_F_12_O	Connected to DLPA200 Number 1 and Number 2 SCPCLK and to R105 36 Ω filter resistor with 27 pF cap after - called DMD_A_SCPCLK_FILTER after - connects to DMD SCPCLK (also connects to R97 filter resistor with 27 pF cap after - called DMD_B_SCPCLK_FILTER but NC after)	-	SCPCLK		SCP Clock
SCPDI	AA15	I	LVC MOS25_S_12_I	1 kΩ pullup to 2.5 V - connects to DLPA200 Number 1 and Number 2 SCPDO and to DMD SCPDO through flex A - on DMD board there is an LCR filter [2 x 100 pF caps, inductor and 34 Ω resistor] also connects to flex B but NC on other end.	-	SCPCLK		SCP data input to DLPC410
SCPDO	AA14	O	LVC MOS25_F_12_O	1 kΩ pullup to 2.5 V - connects to DLPA200 Number 1 and Number 2 SCPDI and to R96 filter cap with 27 pF cap after - called DMD_A_FILTER - connect through flex A to DMD SCPDI - also connects to R71 36 Ω filter resistor with 27 pF cap to DMD_B_SCPDO_FILTER but NC on other end.	-	SCPCLK		SCP data output from DLPC410
STEPVCC	Y13	-	LVC MOS25_S_12_I	1 kΩ pulldown to ground	-	-		Not Used
TCK_JTAG	U11		-	Connects to DLPC410, DLPR410, and JTAG header TCK (if user has JTAG they must build their chain accordingly)	-	TCK_JTAG		JTAG Clock
TDO_DDC	W10		-	Connects to JTAG return TDO on JTAG header	-	TCK_JTAG		JTAG data out of DLPC410
TDO_XCF16DDC	V11		-	Connects to DLPR410 TDO (DLPC410 internal signal TDI_0)	-	TCK_JTAG		JTAG data out of DLPR410 to DLPC410

Pin Functions (continued)

PIN		TYPE	SIGNAL	TERMINATION /NOTES	ACTIVE (Hi or Lo)	CLOCK	DATA RATE	DESCRIPTION
NAME	NO.							
TMS_JTAG	V12		-	Connects to DLPC410, DLPR410, and JTAG header TMS	Hi	TCK_JTAG		JTAG
VBATT_0	K18		-	Connected to 4.7 kΩ pullup to 2.5 V	-	-		Not Used
VCCAUX	J8, K17, L8, M17, N8, P17, R8, T17, U8, V17, W8, W16		POWER	VCC_2P5V	-	-		Aux Power
VCCINT	H15, J12, J14, J16, K9, K13, K15, L10, L12, L14, L16, M9, M11, M15, N10, N12, N16, P9, P11, P15, R10, R12, R16, T9, T11, T13, T15, U10, U12, U14, U16, V9, V13, V15, W14, Y15		POWER	VCC_1P0V	-	-		Power
VCCO_0_1	Y9		POWER	VCC_2P5V	-	-		Power
VCCO_0_2	W12		POWER		-	-		Power
VCCO_1_1	C10		POWER		-	-		Power
VCCO_1_2	F11		POWER		-	-		Power
VCCO_2_1	AA16		POWER		-	-		Power
VCCO_2_2	AD17		POWER		-	-		Power
VCCO_3_1	E14		POWER		-	-		Power
VCCO_3_2	D17		POWER		-	-		Power
VCCO_4_1	AC10		POWER		-	-		Power
VCCO_4_2	AB13		POWER		-	-		Power
VCCO_11_1	F21		POWER		-	-		Power
VCCO_11_2	J22		POWER		-	-		Power
VCCO_11_3	H25		POWER		-	-		Power
VCCO_12_1	J2		POWER		-	-		Power
VCCO_12_2	H5		POWER		-	-		Power
VCCO_12_3	L6		POWER		-	-		Power
VCCO_13_1	R24		POWER		-	-		Power
VCCO_13_2	M23		POWER		-	-		Power
VCCO_13_3	N20		POWER		-	-		Power
VCCO_14_1	V5		POWER		-	-		Power
VCCO_14_2	R4		POWER		-	-		Power
VCCO_14_3	W2		POWER		-	-		Power
VCCO_15_1	E24		POWER		-	-		Power
VCCO_15_2	B23		POWER		-	-		Power
VCCO_15_3	C20		POWER		-	-		Power
VCCO_16_1	G8		POWER		-	-		Power
VCCO_16_2	D7		POWER		-	-		Power
VCCO_16_3	E4		POWER		-	-		Power
VCCO_17_1	V25		POWER		-	-		Power
VCCO_17_2	W22		POWER		-	-		Power
VCCO_17_3	T21		POWER		-	-		Power
VCCO_18_1	AD7		POWER		-	-		Power
VCCO_18_2	AA6		POWER		-	-		Power
VCCO_18_3	AB3		POWER	VCC_2P5V	-	-		Power
VLED0	AC18	O	LVC MOS25_F_12_O	Connects to LED D9 in series with 22.1 Ω resistor to 2.5 V	Hi = On	-		Power Indicator LED Output
VLED1	AD18	O	LVC MOS25_F_12_O	Connects to LED D10 in series with 22.1 Ω resistor to 2.5 V	Hi = On	-		Heartbeat Indicator LED Output
VN_0	P13	-	-	Connect to Ground	-	-		Xilinx System Monitor (not used - must be connected to ground)

Pin Functions (continued)

PIN		TYPE	SIGNAL	TERMINATION /NOTES	ACTIVE (Hi or Lo)	CLOCK	DATA RATE	DESCRIPTION
NAME	NO.							
VP_0	N14	-	-	Connect to Ground	-	-		Xilinx System Monitor (not used - must be connected to ground)
VREFN_0	N13	-	LVC MOS25_S_12	Connect to Ground	-	-		Xilinx System Monitor reference voltage (not used - must be connected to ground)
VREFP_0	P14	-	LVC MOS25_S_12	Connect to Ground	-	-		Xilinx System Monitor reference ground (not used - must be connected to ground)
WDT_ENBL	AA13	I	LVC MOS25_S_12_I		Lo	-		DMD Mirror Clocking Pulse Watchdog Timer Enable
UNUSED	AB23, AC20, AD9, AD16, AD20, AD21, AD23, AD24, AD25, AD26, AE7, AE8, AE10, AE11, AE12, AE13, AE15, AE16, AE17, AE18, AE20, AE21, AE22, AE23, AE24, AE25, AE26, AF7, AF8, AF9, AF10, AF12, AF13, AF14, AF15, AF17, AF18, AF19, AF20, AF22, AF23, AF24, AF25		NC	No Connection (listed as Xilinx NC0 - NC42)	-	-		Unused Pins

7 Specifications

NOTE

The information contained in the following sections has been adapted from the Xilinx XC5VLX30 data sheet. For any information beyond what is listed here, consult the Xilinx XC5VLX30 data sheet. Where appropriate, DLPC410 specific values have been substituted in place of generic parameters.

7.1 Absolute Maximum Ratings

over operating free-air temperature range (unless otherwise noted)⁽¹⁾

		MIN	MAX	UNIT	
ELECTRICAL					
Supply voltage ⁽²⁾	V _{CCINT}	–0.5	1.05	V	
	V _{CCO}	–0.5	3.45	V	
	V _{CCAUX}	2.35	2.625	V	
V _I	Input voltage ⁽³⁾	2.5 V	–0.75	V _{CCO} + 0.5	V
V _O	Output voltage ⁽⁴⁾	2.5 V	–0.3	V _{CCO} + 0.3	V
ENVIRONMENTAL					
T _A	Operating free-air temperature ⁽⁵⁾	0	85	°C	
T _{stg}	Storage temperature	–65	150	°C	

- (1) Stresses beyond those listed under *Absolute Maximum Ratings* may cause permanent damage to the device. These are stress ratings only, and functional operation of the device at these or any other conditions beyond those indicated under *Recommended Operating Conditions* is not implied. Exposure to absolute-maximum-rated conditions for extended periods may affect device reliability.
- (2) All voltage values are with respect to GND.
- (3) Applies to external input and bidirectional buffers.
- (4) Applies to external output and bidirectional buffers.
- (5) Maximum Ambient Temperature may be further limited by the device's power dissipation (which is data and configuration dependent), air flow and resultant junction temperature.

7.2 ESD Ratings

		VALUE	UNIT
V _(ESD)	Electrostatic discharge		
	Human body model (HBM), per ANSI/ESDA/JEDEC JS-001, all pins ⁽¹⁾	2000	V
Charged device model (CDM), per JEDEC specification JESD22-C101, all pins ⁽²⁾	400		

- (1) JEDEC document JEP155 states that 500-V HBM allows safe manufacturing with a standard ESD control process.
- (2) JEDEC document JEP157 states that 250-V CDM allows safe manufacturing with a standard ESD control process.

7.3 Recommended Operating Conditions

over operating free-air temperature range (unless otherwise noted)

		MIN	NOM	MAX	UNIT
V _{CCINT}	1-V Supply voltage, core logic	0.95	1.00	1.05	V
V _{CCO}	2.5-V Supply voltage, I/O	1.14	2.50	3.45	V
V _{CCAUX}	2.5-V Supply voltage, I/O	2.375	2.500	2.625	V
V _I	Input voltage	2.5-V CMOS	0	V _{CCO}	V
		2.5-V LVDS	0.3	2.2	
V _O	Output voltage	2.5-V CMOS	0	V _{CCO}	V
		2.5-V LVDS	0.825	1.675	
T _J	Operating junction temperature ⁽¹⁾	0		125	°C
P _D	Continuous total power dissipation		2.7	2.8	W

- (1) Thermal analysis and design should be carefully considered to ensure that the junction temperature is maintained within the above specifications.

7.4 Electrical Characteristics

over operating free-air temperature range (unless otherwise noted)

PARAMETER		TEST CONDITIONS	MIN	TYP	MAX	UNIT
V _{IH}	High-level Input voltage	2.5-V CMOS	1.7			V
V _{IL}	Low-level Input voltage	2.5-V CMOS			0.7	V
V _{OH}	High-level output voltage	2.5-V Interface	V _{CCO} -4			V
		2.5-V LVDS	1.38			
V _{OL}	Low-level output voltage	2.5-V Interface			0.4	V
		2.5-V LVDS	1.03			
C _I	Input capacitance	2.5-V Interface	8			pF
		2.5-V LVDS	8			
I _{CCINT}	Supply voltage range, core supply		300			mA
I _{CCO}	Supply voltage range, I/O supply		850			mA

7.5 Timing Requirements

 (see ⁽¹⁾)

			MIN	NOM	MAX	UNIT
f _{cd}	Clock frequency, DCLKIN_n ⁽²⁾		395	400	400	MHz
f _{cr}	Clock frequency, CLK_R			50		MHz
t _c	Cycle time, DCLKIN_n		2.5	2.5	2.53	ns
t _{w(H)}	Pulse duration, high	50% to 50% reference points (signal)	1.25	1.25	1.27	ns
t _{w(L)}	Pulse duration, low	50% to 50% reference points (signal)	1.25	1.25	1.27	ns
t _t	Transition time, t _t = t _r / t _f	20% to 80% reference points (signal)			.6	ns
t _{jp}	Period Jitter DCLKIN_n ⁽³⁾			150		ps
t _{sk}	Skew, DIN_A(15-0) to DCLKIN_A		-150		150	ps
	Skew, DIN_B(15-0) to DCLKIN_B		-150		150	
	Skew, DIN_C(15-0) to DCLKIN_C		-150		150	
	Skew, DIN_D(15-0) to DCLKIN_D		-150		150	
	Skew, DVALID_n to DCLKIN_n↑		-150		150	
	Skew, BLK_MD BLK_AD to DCLKIN_n↑ ⁽⁴⁾		-150		150	
	Skew, ROWMD or ROWAD to DCLKIN_n↑ ⁽⁴⁾		-150		150	
	Skew, STEPVCC to DCLKIN↑ ⁽⁴⁾		-150		150	

- (1) It is recommended that the COMP_DATA, NS_FLIP and RST2BLK inputs be set to one value and not adjusted during normal system operation.
- (2) Preferred DCLKIN_n duty cycle = 50%
- (3) This is the deviation in period from ideal period due solely to high frequency jitter.
- (4) First edge of DIN*, ROW*, BLK* and STEPVCC should be synchronous to DVALID rising edge

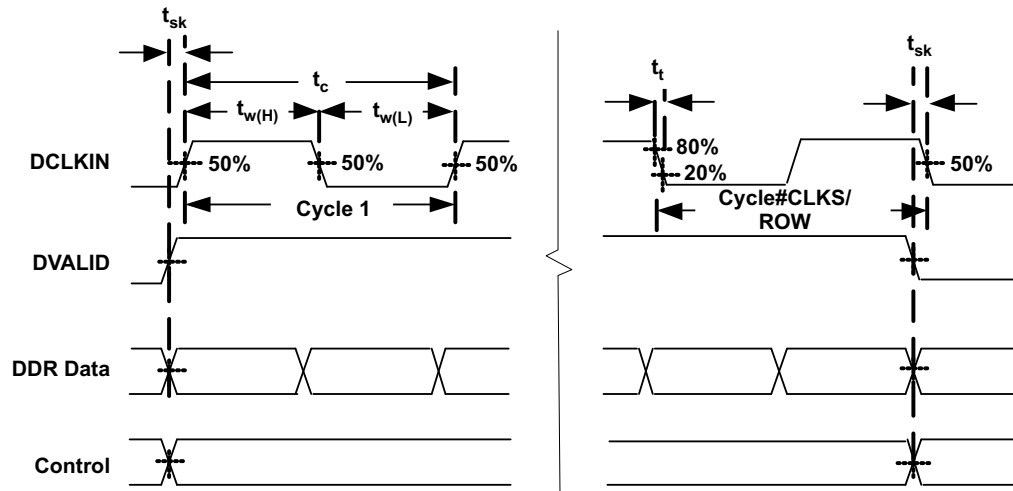
Figure 2. Input Interface Timing
NOTE

Dynamic changes to $\overline{\text{RST2BLK}}$, NS_FLIP and COMP_DATA during normal operation are not recommended.

8 Detailed Description

8.1 Overview

The DLPC410 DMD Digital Controller enables customers to stream binary pattern data to the DLP650LNIR, DLP7000(UV), or DLP9500(UV) DMD for very high speed binary pattern imaging applications. The DLPC410 receives customer input binary pattern data on a row by row basis and passes the pattern data to the connected DMD. Concurrent with the receipt of data, the DLPC410 captures the customer requested ROW mode and ROW address which determines if row loading starts at the top (or bottom) of the DMD and increments (or decrements) to the next row for the next Row Cycle, or if a specific row address is specified for loading the next pattern data. Each DMD micromirror is individually configurable through this data loading process which enables precise, predictable control of each and every micromirror in the DMD Micromirror array.

The DLPC410 also receives customer input control information instructing the DLPC410 to command the DLPA200 device(s) to generate the Mirror Clocking Pulses (MCPs) to the DMD – these MCPs are necessary for the DMD micromirrors to transition from their current state to their new state, the new state being determined by the new data just loaded into the DMD. A feedback signal from the DLPC410 frames the MCP such that the customer knows the MCP request has been received by the DLPC410 and when the MCP is completed.

The DLPC410 supports multiple MCP modes of operation. The DMD Micromirror arrays are arranged into horizontal Reset Blocks – there are typically 16 horizontal Reset Blocks per DMD where each Reset Block receives a single MCP to initiate the Micromirror state change. DMD blocks can be Reset one at a time or all at once. In certain modes, adjacent blocks of 2 or of 4 Reset Blocks can be Reset at the same time. This flexibility provides great advantages to optimizing the time certain DMD blocks are in certain states, which in turn can provide speed advantages or extend DMD illumination windows (the duration for which a solid state illuminator should be illuminating).

Behind the scenes, the DLPC410 also communicates directly with the control logic of the DMD to read part type and status information and to configure the DMD for proper operation. The DLPC410 is always paired with the DLPR410 PROM as the DLPR410 provides the configuration bit stream which configures the DLPC410 to be a DMD Digital Controller. The DLPC410 also drives one DMD at a time, and that DMD could require either one or two DLPA200 devices depending on the DMD type. For further information, refer to [Table 11](#) or the individual DMD datasheets (links can be found in [Table 25](#)).

8.2 Functional Block Diagrams

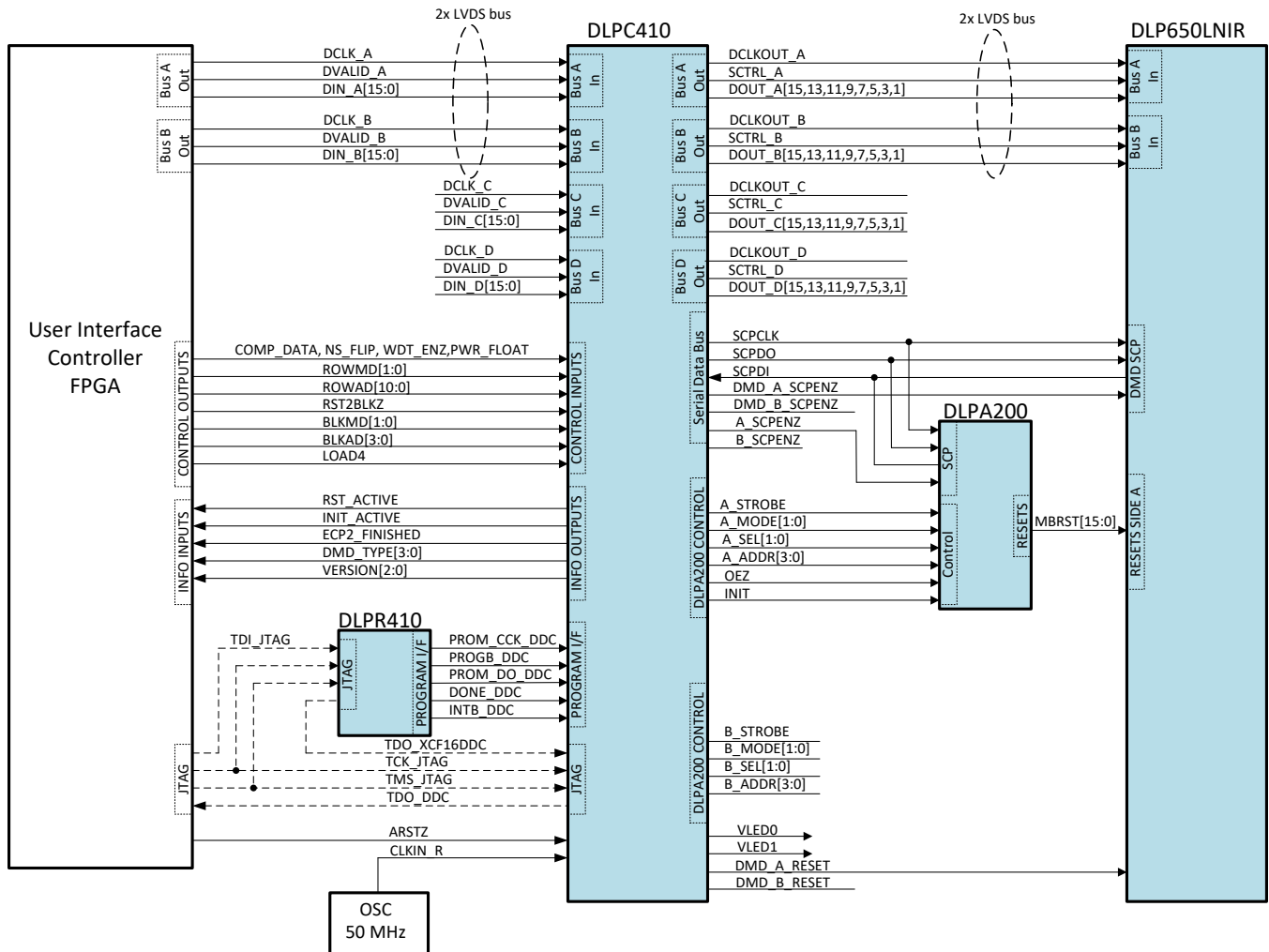

Figure 3. DLPC410 and DLP650LNIR DMD Functional Block Diagram

Functional Block Diagrams (continued)

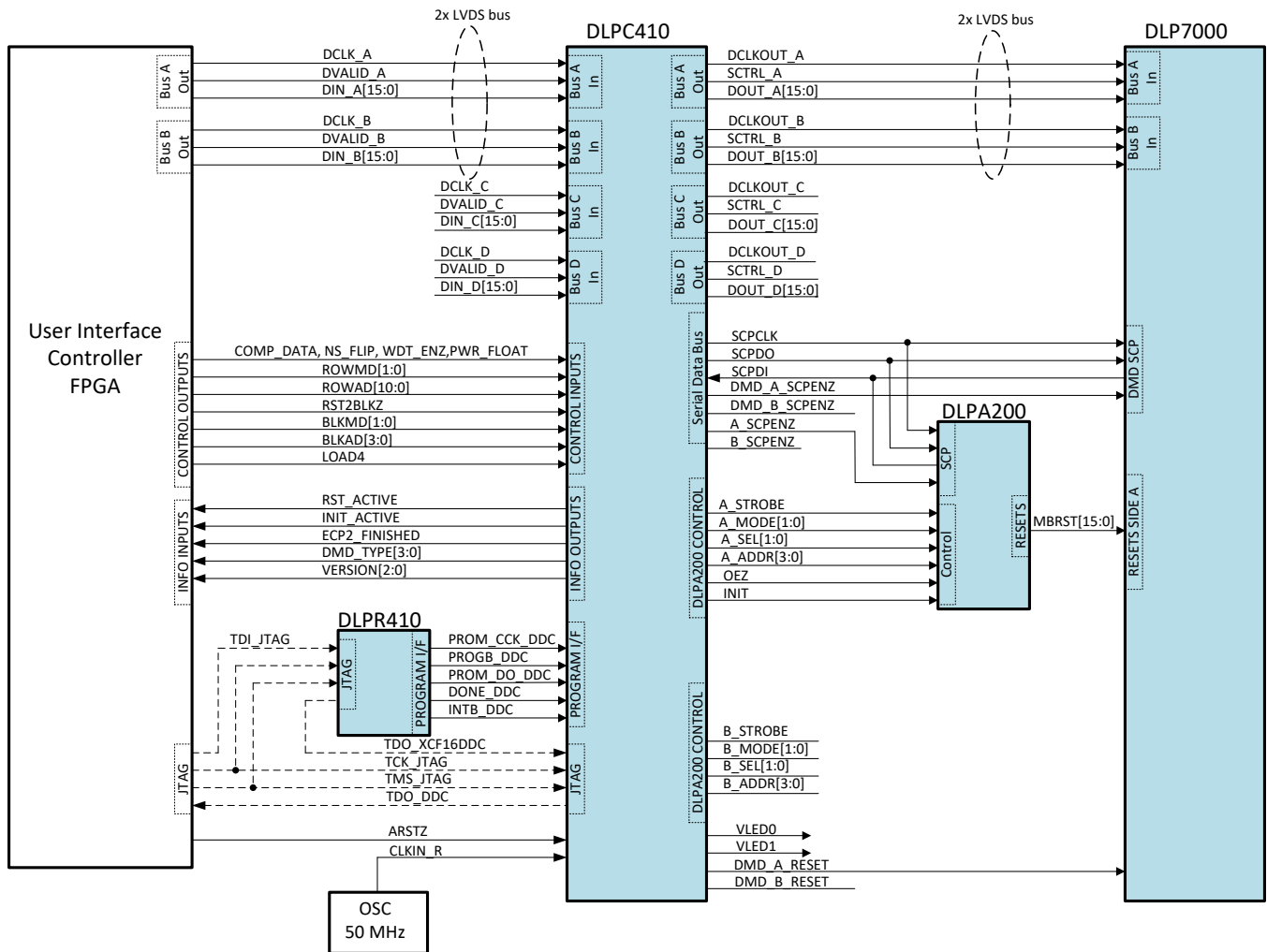

Figure 4. DLPC410 and DLP7000 / DLP7000UV Functional Block Diagram

Functional Block Diagrams (continued)

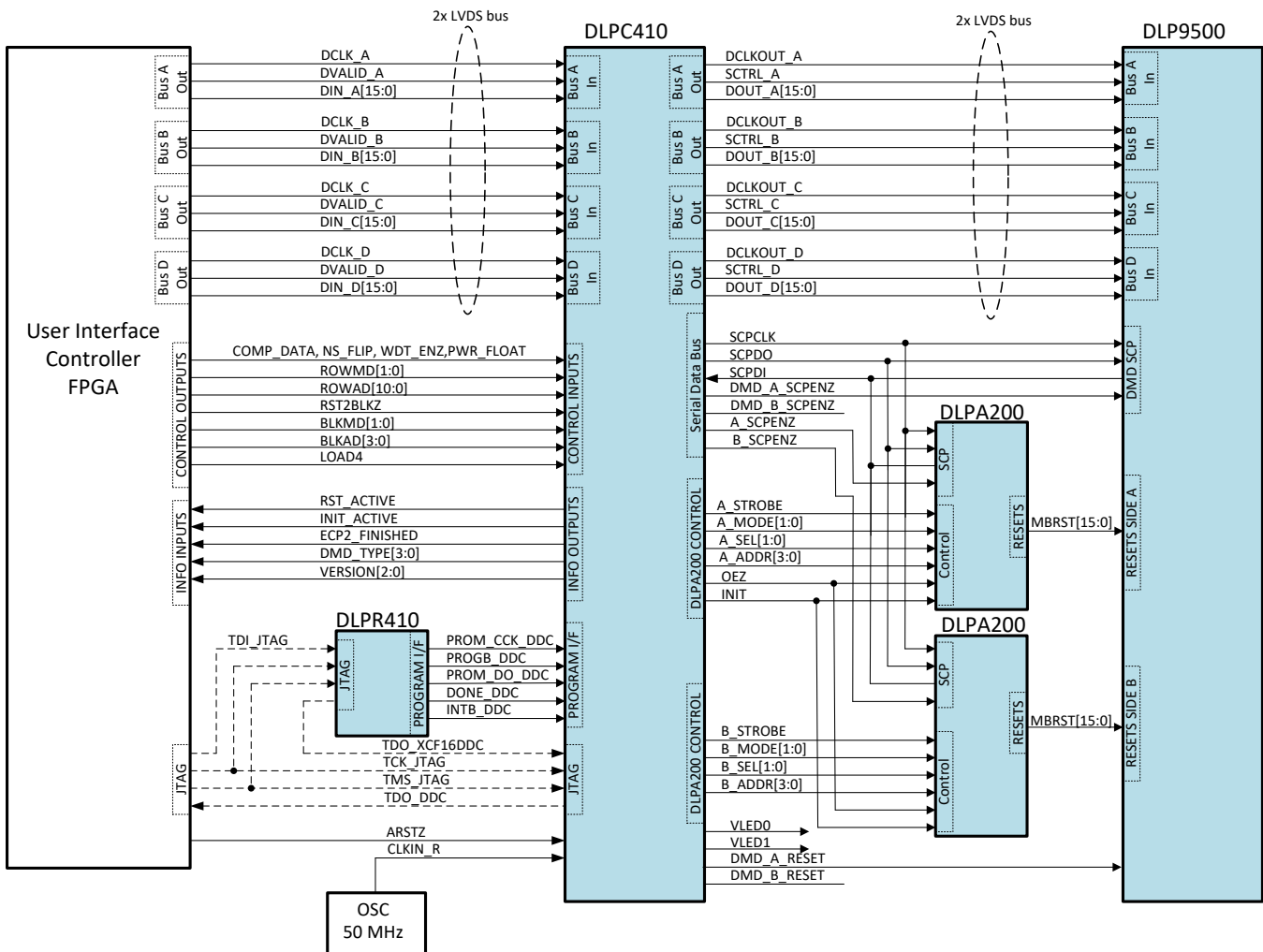

Figure 5. DLPC410 and DLP9500 / DLP9500UV Functional Block Diagram

8.3 Feature Description

8.3.1 DLPC410 Binary Pattern Data Path

The DLPC410 receives binary pattern input data from the customer application formatted specifically for display on one of the DLPC410 compatible DMDs. This data is captured on a row by row basis using specific data formats with multiple signals which frame the data and provided control information from the customer defining where in the DMD the data is destined. The DLPC410 then sends the pattern data to the DMD and uses the received control information to decode and provide the correct control information to the DMD and other DLP components.

8.3.1.1 DIN_A, DIN_B, DIN_C, DIN_D Input Data Buses

The DLPC410 has four differential 16-bit input data buses (A/B/C/D). Which of these input data bus signals are used at any given time is specific to the DMD connected to the DLPC410 in the system. The data buses are 2xLVDS double-data-rate (DDR) buses which can transfer data at 800 MHz data rates per input. Data should be synchronous and edge aligned with the input clocks for each specific data bus (A, B, C, or D). Depending on the design, skewing the clock to data relationship may cause a problem. For timing constraints for the input data clock to either the input data and/or DVALID, refer to [Timing Requirements](#)

Feature Description (continued)

8.3.1.2 DCLKIN Input Clocks

DCLKIN is the differential input clock for each DLPC410 input data bus. There are four input clocks, one for each bus (A/B/C/D). DCLKIN is a 400 MHz clock to the DMD which should be synchronous and edge aligned with all data and control signals for that specific bus (A, B, C, or D). Depending on the design, skewing the clock to data relationship may cause a problem. For timing constraints for the input data clock to either the input data and/or DVALID, refer to [Timing Requirements](#). Care should be taken to keep clock jitter of these signals to a minimum.

8.3.1.3 DVALID Input Signals

The DVALID signal is a differential input signal, one for each input data bus (A/B/C/D), which indicates that data being presented to the DLPC410 is valid. DVALID assertion latches the following types of data into the DLPC410 for decoding or passing information to the DMD:

- Binary pattern data on input data buses A/B/C/D
- Row Mode
- Row Address
- Block Mode
- Block Address
- RST2BLK signal

DVALID and all other inputs listed above should be synchronous to DCLKIN. DVALID can be asserted in one of the three following ways:

- DVALID can frame (remain active) individual DMD row loads with breaks between rows.
- DVALID can frame continuous DMD block loads of multiple rows with breaks between blocks
- DVALID can frame (remain active) the entire DMD device load (all rows) without any breaks.

If the DVALID frames individual blocks or the entire DMD, ensure that block and row controls are adjusted at the proper locations in the data stream. See section [DLPC410 Initialization and Training](#) for further information.

NOTE

After an active DVALID signal transitions inactive (low), DVALID should only transition to active again on even number of clocks later, i.e. 2, 4, 6, etc.

8.3.1.4 DOUT_A, DOUT_B, DOUT_C, DOUT_D Output Data Buses

The DLPC410, having captured the incoming pattern data on its input data buses, provides this data on an equivalent number of output data buses. The DLPC410 has four differential 16-bit output data buses (A/B/C/D), which are aligned to its input data buses. Which of these input data bus signals are used at any given time is specific to the DMD connected to the DLPC410 in the system. The data buses are 2xLVDS double-data-rate (DDR) buses which can transfer data at 800 MHz data rates per output. Data should be synchronous and edge aligned with the output clocks for each specific data bus (A, B, C, or D). Depending on the design, skewing the clock to data relationship may cause a problem. For timing constraints for the output data clock to the output data, refer to [Timing Requirements](#).

8.3.1.5 DCLKOUT Output Clocks

DCLKOUT is the differential output clock for each DLPC410 output data bus. There are four output data clocks, one for each bus (A/B/C/D) to the DMD. DCLKOUT is a 400 MHz clock to the DMD which should be synchronous and edge aligned with all data and control signals for that specific bus (A, B, C, or D). Depending on the design, skewing the clock to data relationship may cause a problem. For timing constraints for the output data clocks to either the output data and/or SCTRL signals, refer to [Timing Requirements](#).

Feature Description (continued)

8.3.1.6 SCTRL Output Signals

The SCTRL signal is a differential output signal to the DMD which provides DMD control information. There are four SCTRL differential pair signals, one for each bus (A/B/C/D). The control information is generated internally to the DLPC410 and is specific to the connected DMD. Data should be synchronous and edge aligned with the output clocks for each specific data bus (A, B, C, or D). Depending on the design, skewing the clock to SCTRL relationship may cause a problem. For timing constraints for the output data clock to the SCTRL signals, refer to [Timing Requirements](#).

8.3.1.7 Supported DMD Bus Sizes

The DLPC410 supports the 2xLVDS Data Bus DMD types as shown in [Table 11](#).

Table 2. DMD Row Sizes, Bus Widths, and Row Lengths

TYPE	PIXELS PER ROW	INPUT / OUTPUT BUSS	NO. OF DATA LINES	CLOCKS PER ROW
DLP650LNIR DMD	1280	A[15,13,11,9,7,5,3,1] B[15,13,11,9,7,5,3,1]	16	40
DLP7000 and DLP7000UV DMDs	1024	A[15:0] B[15:0]	32	16
DLP9500 and DLP9500UV DMDs	1920 (2048)	A[15:0] B[15:0] C[15:0] D[15:0]	64	16

8.3.1.8 Row Cycle definition

A Row Cycle relates to specific number of input data clocks it takes for the customer to send one row of input binary pattern data to one row of the DMD. DVALID starts the Row Cycle by transitioning to an active (logic '1') state. The row cycle ends after the appropriate number of clock cycles per row are applied. Any input data on the DIN input data buses should be appropriately provided during the Row Cycle. [Table 2](#) shows the number of input data clocks needing to populate one row of the DMD using the number of data lines identified in the table. Other Row and Block related signals are captured at the start of a row cycle and will be discussed later.

There is also a unique row cycle called a No-Op Row Cycle which does not provide any valid input data nor any valid block command. It is typically used to do nothing except provide the DLPC410 and DMD time to perform internal actions already in process. The No-Op Row Cycle is discussed in [No-Op Row Cycle Description](#).

8.3.1.9 DLP9500 and DLP9500UV Input Data Formatting

Figure 6 details one Row Cycle of input data formatting for the DLP9500 and DLP9500UV DMDs. For brevity, only two data bits of all four 16 bit data bus (A/B/C/D) signals are shown, but there is enough information presented to allow extrapolation to all data bus signals not shown.

Table 3, Table 4, Table 5, and Table 6 show how each pixel of the DLP9500 and DLP9500UV DMDs maps to individual data bus inputs and input clock edges within each row cycle. Because these DMDs are actually 2048 pixels per row with only 1920 micromirrors per row, no visible data is loaded for the first clock cycle for A and B data and for the last clock cycle for C and D data for each row load operation. This only applies to the DLP9500 and DLP9500UV. For readability purposes, input buses DIN_A, DIN_B, DIN_C, and DIN_D are abbreviated as D_A, D_B, D_C, and D_D. DCLKIN has been shortened to DCLK.

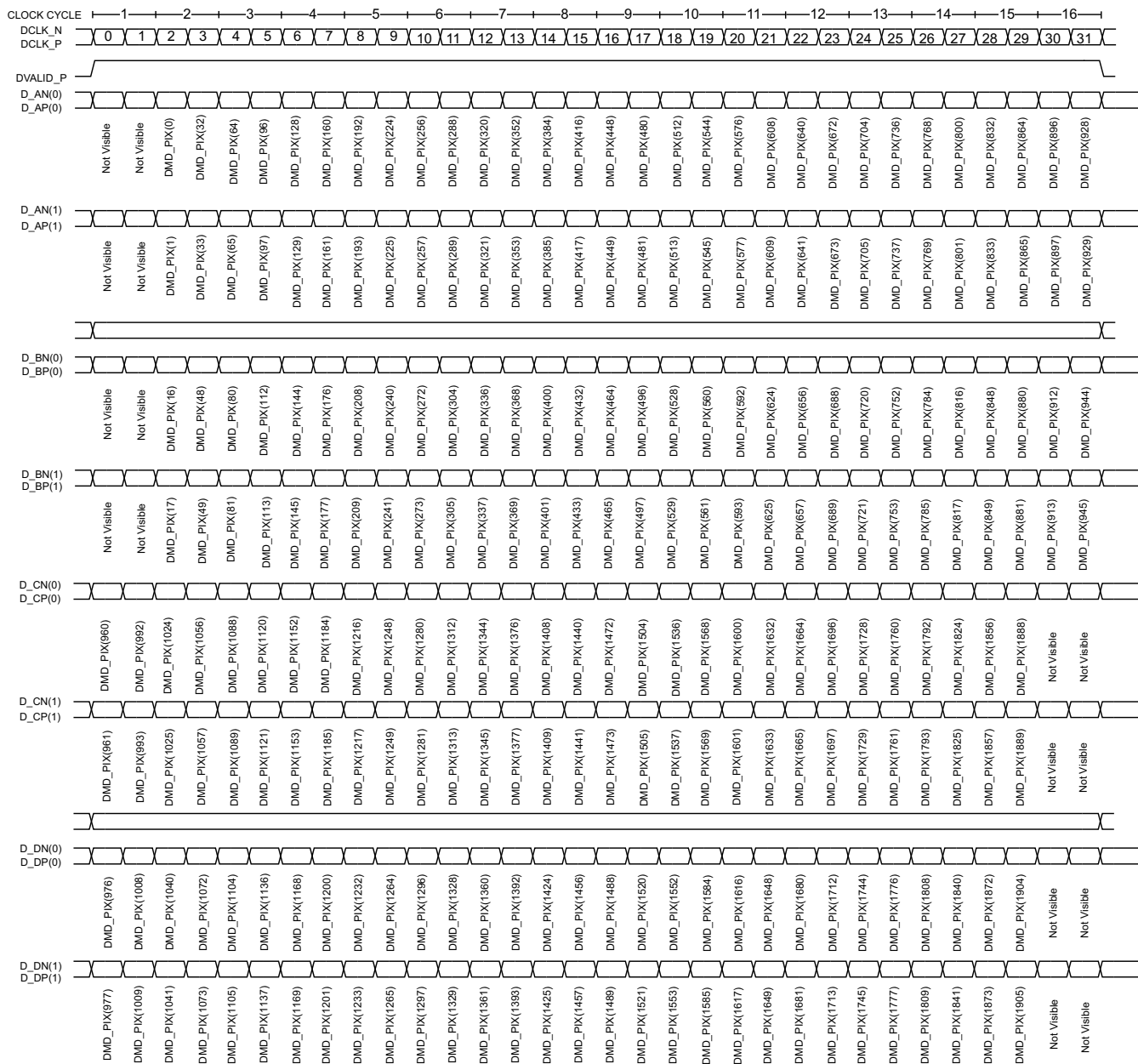

Figure 6. DLP9500 / DLP9500UV 2XLVDS DMD Input Data Bus

Table 3. DLP9500 / DLP9500UV 2XLVDS DMD Data Pixel Mapping D_A(15:0)

DCLK EDGE	D_A(0)	D_A(1)	D_A(2)	D_A(3)	D_A(4)	D_A(5)	D_A(6)	D_A(7)	D_A(8)	D_A(9)	D_A(10)	D_A(11)	D_A(12)	D_A(13)	D_A(14)	D_A(15)
0	Not Visible															
1	Not Visible															
2	0	1	2	3	4	5	6	7	8	9	10	11	12	13	14	15
3	32	33	34	35	36	37	38	39	40	41	42	43	44	45	46	47
4	64	65	66	67	68	69	70	71	72	73	74	75	76	77	78	79
5	96	97	98	99	100	101	102	103	104	105	106	107	108	109	110	111
6	128	129	130	131	132	133	134	135	136	137	138	139	140	141	142	143
7	160	161	162	163	164	165	166	167	168	169	170	171	172	173	174	175
8	192	193	194	195	196	197	198	199	200	201	202	203	204	205	206	207
9	224	225	226	227	228	229	230	231	232	233	234	235	236	237	238	239
10	256	257	258	259	260	261	262	263	264	265	266	267	268	269	270	271
11	288	289	290	291	292	293	294	295	296	297	298	299	300	301	302	303
12	320	321	322	323	324	325	326	327	328	329	330	331	332	333	334	335
13	352	353	354	355	356	357	358	359	360	361	362	363	364	365	366	367
14	384	385	386	387	388	389	390	391	392	393	394	395	396	397	398	399
15	416	417	418	419	420	421	422	423	424	425	426	427	428	429	430	431
16	448	449	450	451	452	453	454	455	456	457	458	459	460	461	462	463
17	480	481	482	483	484	485	486	487	488	489	490	491	492	493	494	495
18	512	513	514	515	516	517	518	519	520	521	522	523	524	525	526	527
19	544	545	546	547	548	549	550	551	552	553	554	555	556	557	558	559
20	576	577	578	579	580	581	582	583	584	585	586	587	588	589	590	591
21	608	609	610	611	612	613	614	615	616	617	618	619	620	621	622	623
22	640	641	642	643	644	645	646	647	648	649	650	651	652	653	654	655
23	672	673	674	675	676	677	678	679	680	681	682	683	684	685	686	687
24	704	705	706	707	708	709	710	711	712	713	714	715	716	717	718	719
25	736	737	738	739	740	741	742	743	744	745	746	747	748	749	750	751
26	768	769	770	771	772	773	774	775	776	777	778	779	780	781	782	783
27	800	801	802	803	804	805	806	807	808	809	810	811	812	813	814	815
28	832	833	834	835	836	837	838	839	840	841	842	843	844	845	846	847
29	864	865	866	867	868	869	870	871	872	873	874	875	876	877	878	879
30	896	897	898	899	900	901	902	903	904	905	906	907	908	909	910	911
31	928	929	930	931	932	933	934	935	936	937	938	939	940	941	942	943

Table 4. DLP9500 / DLP9500UV 2XLVDS DMD Data Pixel Mapping D_B(15:0)

DCLK EDGE	D_B(0)	D_B(1)	D_B(2)	D_B(3)	D_B(4)	D_B(5)	D_B(6)	D_B(7)	D_B(8)	D_B(9)	D_B(10)	D_B(11)	D_B(12)	D_B(13)	D_B(14)	D_B(15)
0	Not Visible															
1	Not Visible															
2	16	17	18	19	20	21	22	23	24	25	26	27	28	29	30	31
3	48	49	50	51	52	53	54	55	56	57	58	59	60	61	62	63
4	80	81	82	83	84	85	86	87	88	89	90	91	92	93	94	95
5	112	113	114	115	116	117	118	119	120	121	122	123	124	125	126	127
6	144	145	146	147	148	149	150	151	152	153	154	155	156	157	158	159
7	176	177	178	179	180	181	182	183	184	185	186	187	188	189	190	191
8	208	209	210	211	212	213	214	215	216	217	218	219	220	221	222	223
9	240	241	242	243	244	245	246	247	248	249	250	251	252	253	254	255
10	272	273	274	275	276	277	278	279	280	281	282	283	284	285	286	287
11	304	305	306	307	308	309	310	311	312	313	314	315	316	317	318	319
12	336	337	338	339	340	341	342	343	344	345	346	347	348	349	350	351
13	368	369	370	371	372	373	374	375	376	377	378	379	380	381	382	383
14	400	401	402	403	404	405	406	407	408	409	410	411	412	413	414	415
15	432	433	434	435	436	437	438	439	440	441	442	443	444	445	446	447
16	464	465	466	467	468	469	470	471	472	473	474	475	476	477	478	479
17	496	497	498	499	500	501	502	503	504	505	506	507	508	509	510	511
18	528	529	530	531	532	533	534	535	536	537	538	539	540	541	542	543
19	560	561	562	563	564	565	566	567	568	569	570	571	572	573	574	575
20	592	593	594	595	596	597	598	599	600	601	602	603	604	605	606	607
21	624	625	626	627	628	629	630	631	632	633	634	635	636	637	638	639
22	656	657	658	659	660	661	662	663	664	665	666	667	668	669	670	671
23	688	689	690	691	692	693	694	695	696	697	698	699	700	701	702	703
24	720	721	722	723	724	725	726	727	728	729	730	731	732	733	734	735
25	752	753	754	755	756	757	758	759	760	761	762	763	764	765	766	767
26	784	785	786	787	788	789	790	791	792	793	794	795	796	797	798	799
27	816	817	818	819	820	821	822	823	824	825	826	827	828	829	830	831
28	848	849	850	851	852	853	854	855	856	857	858	859	860	861	862	863
29	880	881	882	883	884	885	886	887	888	889	890	891	892	893	894	895
30	912	913	914	915	916	917	918	919	920	921	922	923	924	925	926	927
31	944	945	946	947	948	949	950	951	952	953	954	955	956	957	958	959

Table 5. DLP9500 / DLP9500UV 2XLVDS DMD Data Pixel Mapping D_C(15:0)

DCLK EDGE	D_C(0)	D_C(1)	D_C(2)	D_C(3)	D_C(4)	D_C(5)	D_C(6)	D_C(7)	D_C(8)	D_C(9)	D_C(10)	D_C(11)	D_C(12)	D_C(13)	D_C(14)	D_C(15)
0	960	961	962	963	964	965	966	967	968	969	970	971	972	973	974	975
1	992	993	994	995	996	997	998	999	1000	1001	1002	1003	1004	1005	1006	1007
2	1024	1025	1026	1027	1028	1029	1030	1031	1032	1033	1034	1035	1036	1037	1038	1039
3	1056	1057	1058	1059	1060	1061	1062	1063	1064	1065	1066	1067	1068	1069	1070	1071
4	1088	1089	1090	1091	1092	1093	1094	1095	1096	1097	1098	1099	1100	1101	1102	1103
5	1120	1121	1122	1123	1124	1125	1126	1127	1128	1129	1130	1131	1132	1133	1134	1135
6	1152	1153	1154	1155	1156	1157	1158	1159	1160	1161	1162	1163	1164	1165	1166	1167
7	1184	1185	1186	1187	1188	1189	1190	1191	1192	1193	1194	1195	1196	1197	1198	1199
8	1216	1217	1218	1219	1220	1221	1222	1223	1224	1225	1226	1227	1228	1229	1230	1231
9	1248	1249	1250	1251	1252	1253	1254	1255	1256	1257	1258	1259	1260	1261	1262	1263
10	1280	1281	1282	1283	1284	1285	1286	1287	1288	1289	1290	1291	1292	1293	1294	1295
11	1312	1313	1314	1315	1316	1317	1318	1319	1320	1321	1322	1323	1324	1325	1326	1327
12	1344	1345	1346	1347	1348	1349	1350	1351	1352	1353	1354	1355	1356	1357	1358	1359
13	1376	1377	1378	1379	1380	1381	1382	1383	1384	1385	1386	1387	1388	1389	1390	1391
14	1408	1409	1410	1411	1412	1413	1414	1415	1416	1417	1418	1419	1420	1421	1422	1423
15	1440	1441	1442	1443	1444	1445	1446	1447	1448	1449	1450	1451	1452	1453	1454	1455
16	1472	1473	1474	1475	1476	1477	1478	1479	1480	1481	1482	1483	1484	1485	1486	1487
17	1504	1505	1506	1507	1508	1509	1510	1511	1512	1513	1514	1515	1516	1517	1518	1519
18	1536	1537	1538	1539	1540	1541	1542	1543	1544	1545	1546	1547	1548	1549	1550	1551
19	1568	1569	1570	1571	1572	1573	1574	1575	1576	1577	1578	1579	1580	1581	1582	1583
20	1600	1601	1602	1603	1604	1605	1606	1607	1608	1609	1610	1611	1612	1613	1614	1615
21	1632	1633	1634	1635	1636	1637	1638	1639	1640	1641	1642	1643	1644	1645	1646	1647
22	1664	1665	1666	1667	1668	1669	1670	1671	1672	1673	1674	1675	1676	1677	1678	1679
23	1696	1697	1698	1699	1700	1701	1702	1703	1704	1705	1706	1707	1708	1709	1710	1711
24	1728	1729	1730	1731	1732	1733	1734	1735	1736	1737	1738	1739	1740	1741	1742	1743
25	1760	1761	1762	1763	1764	1765	1766	1767	1768	1769	1770	1771	1772	1773	1774	1775
26	1792	1793	1794	1795	1796	1797	1798	1799	1800	1801	1802	1803	1804	1805	1806	1807
27	1824	1825	1826	1827	1828	1829	1830	1831	1832	1833	1834	1835	1836	1837	1838	1839
28	1856	1857	1858	1859	1860	1861	1862	1863	1864	1865	1866	1867	1868	1869	1870	1871
29	1888	1889	1890	1891	1892	1893	1894	1895	1896	1897	1898	1899	1900	1901	1902	1903
30	Not Visible															
31																

Table 6. DLP9500 / DLP9500UV 2XLVDS DMD Data Pixel Mapping D_D(15:0)

DCLK EDGE	D_D(0)	D_D(1)	D_D(2)	D_D(3)	D_D(4)	D_D(5)	D_D(6)	D_D(7)	D_D(8)	D_D(9)	D_D(10)	D_D(11)	D_D(12)	D_D(13)	D_D(14)	D_D(15)
0	976	977	978	979	980	981	982	983	984	985	986	987	988	989	990	991
1	1008	1009	1010	1011	1012	1013	1014	1015	1016	1017	1018	1019	1020	1021	1022	1023
2	1040	1041	1042	1043	1044	1045	1046	1047	1048	1049	1050	1051	1052	1053	1054	1055
3	1072	1073	1074	1075	1076	1077	1078	1079	1080	1081	1082	1083	1084	1085	1086	1087
4	1104	1105	1106	1107	1108	1109	1110	1111	1112	1113	1114	1115	1116	1117	1118	1119
5	1136	1137	1138	1139	1140	1141	1142	1143	1144	1145	1146	1147	1148	1149	1150	1151
6	1168	1169	1170	1171	1172	1173	1174	1175	1176	1177	1178	1179	1180	1181	1182	1183
7	1200	1201	1202	1203	1204	1205	1206	1207	1208	1209	1210	1211	1212	1213	1214	1215
8	1232	1233	1234	1235	1236	1237	1238	1239	1240	1241	1242	1243	1244	1245	1246	1247
9	1264	1265	1266	1267	1268	1269	1270	1271	1272	1273	1274	1275	1276	1277	1278	1279
10	1296	1297	1298	1299	1300	1301	1302	1303	1304	1305	1306	1307	1308	1309	1310	1311
11	1328	1329	1330	1331	1332	1333	1334	1335	1336	1337	1338	1339	1340	1341	1342	1343
12	1360	1361	1362	1363	1364	1365	1366	1367	1368	1369	1370	1371	1372	1373	1374	1375
13	1392	1393	1394	1395	1396	1397	1398	1399	1400	1401	1402	1403	1404	1405	1406	1407
14	1424	1425	1426	1427	1428	1429	1430	1431	1432	1433	1434	1435	1436	1437	1438	1439
15	1456	1457	1458	1459	1460	1461	1462	1463	1464	1465	1466	1467	1468	1469	1470	1471
16	1488	1489	1490	1491	1492	1493	1494	1495	1496	1497	1498	1499	1500	1501	1502	1503
17	1520	1521	1522	1523	1524	1525	1526	1527	1528	1529	1530	1531	1532	1533	1534	1535
18	1552	1553	1554	1555	1556	1557	1558	1559	1560	1561	1562	1563	1564	1565	1566	1567
19	1584	1585	1586	1587	1588	1589	1590	1591	1592	1593	1594	1595	1596	1597	1598	1599
20	1616	1617	1618	1619	1620	1621	1622	1623	1624	1625	1626	1627	1628	1629	1630	1631
21	1648	1649	1650	1651	1652	1653	1654	1655	1656	1657	1658	1659	1660	1661	1662	1663
22	1680	1681	1682	1683	1684	1685	1686	1687	1688	1689	1690	1691	1692	1693	1694	1695
23	1712	1713	1714	1715	1716	1717	1718	1719	1720	1721	1722	1723	1724	1725	1726	1727
24	1744	1745	1746	1747	1748	1749	1750	1751	1752	1753	1754	1755	1756	1757	1758	1759
25	1776	1777	1778	1779	1780	1781	1782	1783	1784	1785	1786	1787	1788	1789	1790	1791
26	1808	1809	1810	1811	1812	1813	1814	1815	1816	1817	1818	1819	1820	1821	1822	1823
27	1840	1841	1842	1843	1844	1845	1846	1847	1848	1849	1850	1851	1852	1853	1854	1855
28	1872	1873	1874	1875	1876	1877	1878	1879	1880	1881	1882	1883	1884	1885	1886	1887
29	1904	1905	1906	1907	1908	1909	1910	1911	1912	1913	1914	1915	1916	1917	1918	1919
30	Not Visible															
31																

8.3.1.10 DLP7000 and DLP7000UV Input Data Bus

Figure 7 details one row cycle of input data formatting for the DLP7000 and DLP7000UV DMDs. For brevity, only two data bits of both 16 bit data bus (A/B) signals are shown, but there is enough information presented to allow extrapolation to data bus signals not shown.

Table 7 and Table 8 show how each pixel of the DLP7000 and DLP7000UV DMDs maps to individual data bus inputs and input clock edges within each row load operation.

NOTE

In the following charts, for readability purposes input buses DIN_A, DIN_B are abbreviated as D_A, D_B. DCLKIN has been shortened to DCLK.

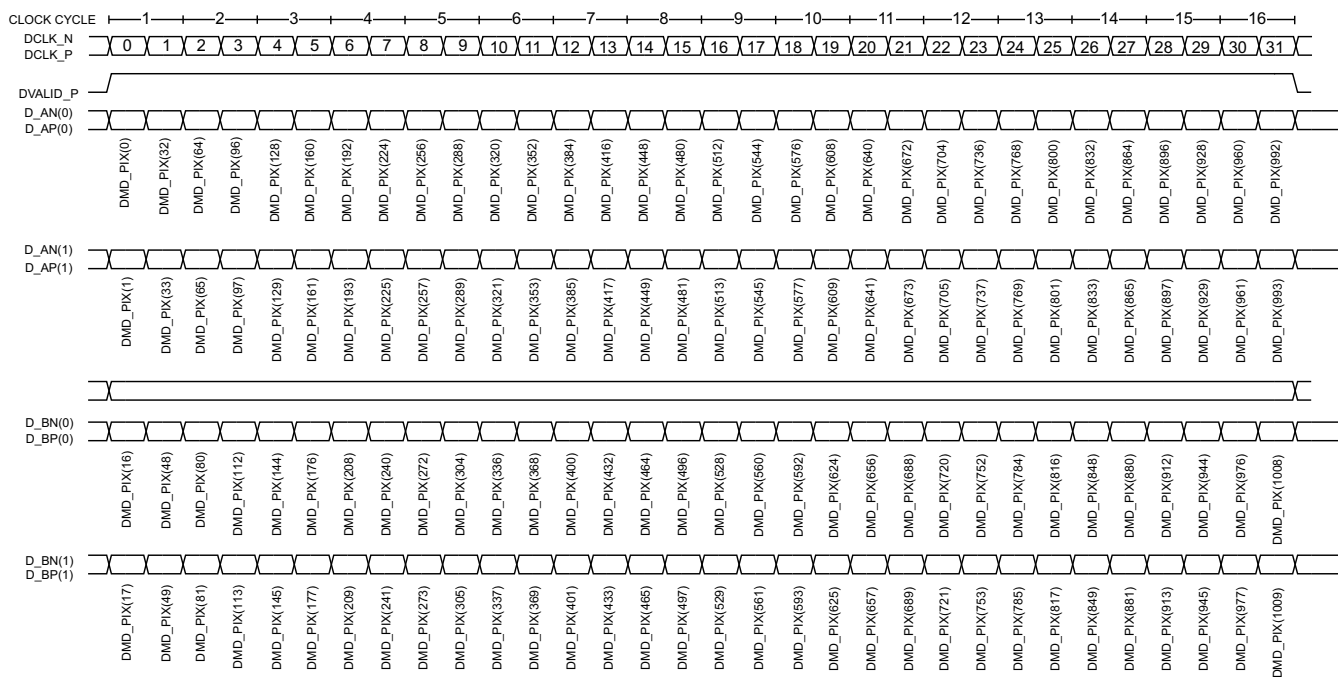

Figure 7. DLP7000 / DLP7000UV 2XLVDS DMD Input Data Bus

Table 7. DLP7000 / DLP7000UV 2XLVDS DMD Data Pixel Mapping D_A(15:0)

DCLK EDGE	D_A(0)	D_A(1)	D_A(2)	D_A(3)	D_A(4)	D_A(5)	D_A(6)	D_A(7)	D_A(8)	D_A(9)	D_A(10)	D_A(11)	D_A(12)	D_A(13)	D_A(14)	D_A(15)
0	0	1	2	3	4	5	6	7	8	9	10	11	12	13	14	15
1	32	33	34	35	36	37	38	39	40	41	42	43	44	45	46	47
2	64	65	66	67	68	69	70	71	72	73	74	75	76	77	78	79
3	96	97	98	99	100	101	102	103	104	105	106	107	108	109	110	111
4	128	129	130	131	132	133	134	135	136	137	138	139	140	141	142	143
5	160	161	162	163	164	165	166	167	168	169	170	171	172	173	174	175
6	192	193	194	195	196	197	198	199	200	201	202	203	204	205	206	207
7	224	225	226	227	228	229	230	231	232	233	234	235	236	237	238	239
8	256	257	258	259	260	261	262	263	264	265	266	267	268	269	270	271
9	288	289	290	291	292	293	294	295	296	297	298	299	300	301	302	303
10	320	321	322	323	324	325	326	327	328	329	330	331	332	333	334	335
11	352	353	354	355	356	357	358	359	360	361	362	363	364	365	366	367
12	384	385	386	387	388	389	390	391	392	393	394	395	396	397	398	399
13	416	417	418	419	420	421	422	423	424	425	426	427	428	429	430	431
14	448	449	450	451	452	453	454	455	456	457	458	459	460	461	462	463
15	480	481	482	483	484	485	486	487	488	489	490	491	492	493	494	495
16	512	513	514	515	516	517	518	519	520	521	522	523	524	525	526	527
17	544	545	546	547	548	549	550	551	552	553	554	555	556	557	558	559
18	576	577	578	579	580	581	582	583	584	585	586	587	588	589	590	591
19	608	609	610	611	612	613	614	615	616	617	618	619	620	621	622	623
20	640	641	642	643	644	645	646	647	648	649	650	651	652	653	654	655
21	672	673	674	675	676	677	678	679	680	681	682	683	684	685	686	687
22	704	705	706	707	708	709	710	711	712	713	714	715	716	717	718	719
23	736	737	738	739	740	741	742	743	744	745	746	747	748	749	750	751
24	768	769	770	771	772	773	774	775	776	777	778	779	780	781	782	783
25	800	801	802	803	804	805	806	807	808	809	810	811	812	813	814	815
26	832	833	834	835	836	837	838	839	840	841	842	843	844	845	846	847
27	864	865	866	867	868	869	870	871	872	873	874	875	876	877	878	879
28	896	897	898	899	900	901	902	903	904	905	906	907	908	909	910	911
29	928	929	930	931	932	933	934	935	936	937	938	939	940	941	942	943
30	960	961	962	963	964	965	966	967	968	969	970	971	972	973	974	975
31	992	993	994	995	996	997	998	999	1000	1001	1002	1003	1004	1005	1006	1007

Table 8. DLP7000 / DLP7000UV 2XLVDS DMD Data Pixel Mapping D_B(15:0)

DCLK EDGE	D_B(0)	D_B(1)	D_B(2)	D_B(3)	D_B(4)	D_B(5)	D_B(6)	D_B(7)	D_B(8)	D_B(9)	D_B(10)	D_B(11)	D_B(12)	D_B(13)	D_B(14)	D_B(15)
0	16	17	18	19	20	21	22	23	24	25	26	27	28	29	30	31
1	48	49	50	51	52	53	54	55	56	57	58	59	60	61	62	63
2	80	81	82	83	84	85	86	87	88	89	90	91	92	93	94	95
3	112	113	114	115	116	117	118	119	120	121	122	123	124	125	126	127
4	144	145	146	147	148	149	150	151	152	153	154	155	156	157	158	159
5	176	177	178	179	180	181	182	183	184	185	186	187	188	189	190	191
6	208	209	210	211	212	213	214	215	216	217	218	219	220	221	222	223
7	240	241	242	243	244	245	246	247	248	249	250	251	252	253	254	255
8	272	273	274	275	276	277	278	279	280	281	282	283	284	285	286	287
9	304	305	306	307	308	309	310	311	312	313	314	315	316	317	318	319
10	336	337	338	339	340	341	342	343	344	345	346	347	348	349	350	351
11	368	369	370	371	372	373	374	375	376	377	378	379	380	381	382	383
12	400	401	402	403	404	405	406	407	408	409	410	411	412	413	414	415
13	432	433	434	435	436	437	438	439	440	441	442	443	444	445	446	447
14	464	465	466	467	468	469	470	471	472	473	474	475	476	477	478	479
15	496	497	498	499	500	501	502	503	504	505	506	507	508	509	510	511
16	528	529	530	531	532	533	534	535	536	537	538	539	540	541	542	543
17	560	561	562	563	564	565	566	567	568	569	570	571	572	573	574	575
18	592	593	594	595	596	597	598	599	600	601	602	603	604	605	606	607
19	624	625	626	627	628	629	630	631	632	633	634	635	636	637	638	639
20	656	657	658	659	660	661	662	663	664	665	666	667	668	669	670	671
21	688	689	690	691	692	693	694	695	696	697	698	699	700	701	702	703
22	720	721	722	723	724	725	726	727	728	729	730	731	732	733	734	735
23	752	753	754	755	756	757	758	759	760	761	762	763	764	765	766	767
24	784	785	786	787	788	789	790	791	792	793	794	795	796	797	798	799
25	816	817	818	819	820	821	822	823	824	825	826	827	828	829	830	831
26	848	849	850	851	852	853	854	855	856	857	858	859	860	861	862	863
27	880	881	882	883	884	885	886	887	888	889	890	891	892	893	894	895
28	912	913	914	915	916	917	918	919	920	921	922	923	924	925	926	927
29	944	945	946	947	948	949	950	951	952	953	954	955	956	957	958	959
30	976	977	978	979	980	981	982	983	984	985	986	987	988	989	990	991
31	1008	1009	1010	1011	1012	1013	1014	1015	1016	1017	1018	1019	1020	1021	1022	1023

8.3.1.11 DLP650LNIR Input Data Bus

Figure 8 details one row cycle of input data formatting for the DLP650LNIR DMD. For brevity, only two data bits of both 8 bit data bus (A/B) signals are shown, but there is enough information presented to allow extrapolation to data bus signals not shown.

Table 9 and Table 10 show how each pixel of the DLP650LNIR DMD maps to individual data bus inputs and input clock edges within each row load operation.

NOTE

In the following charts, for readability purposes input buses DIN_A, DIN_B are abbreviated as D_A, D_B. DCLKIN has been shortened to DCLK.

Since showing the entire 40 clock row cycle would make this chart unreadable, the chart has been broken in the middle. However, there is enough information available to allow extrapolation of the missing data.

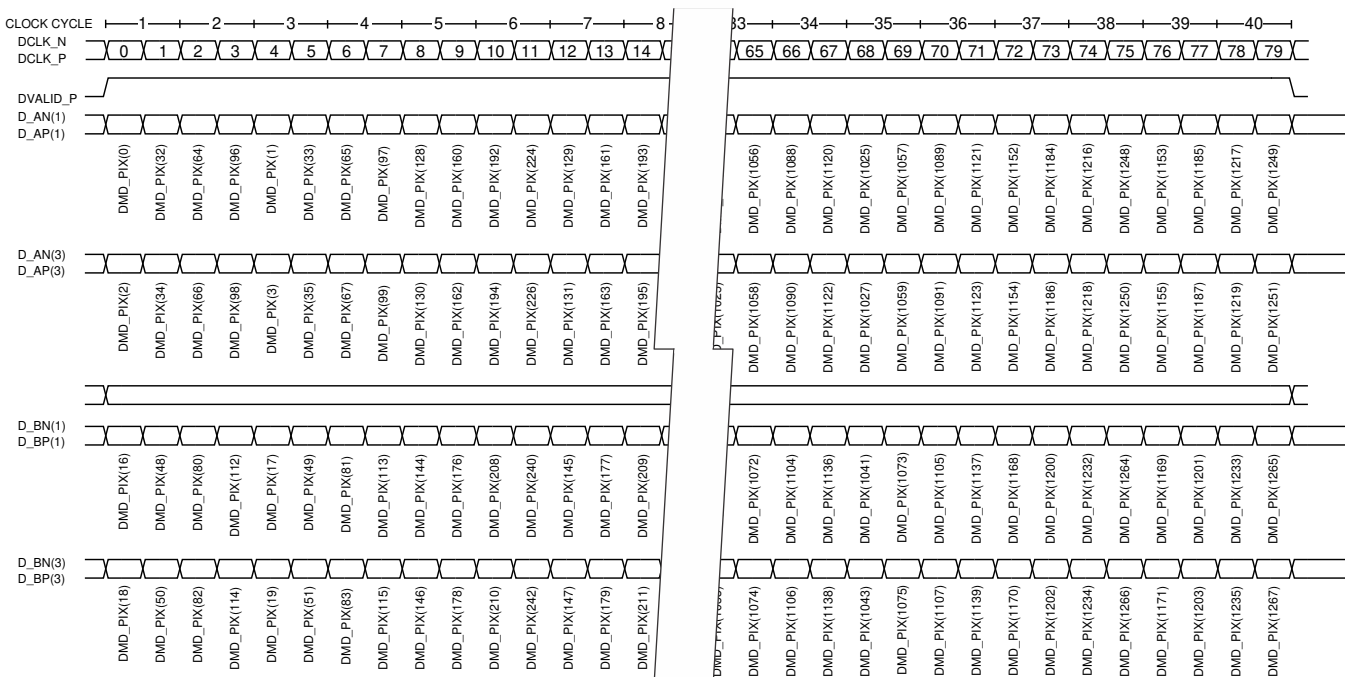

Figure 8. DLP650LNIR 2xLVDS DMD Input Data Bus

Table 9. DLP650LNIR 2xLVDS DMD Data Pixel Mapping D_A(15,13,11,9,7,5,3,1)

DCLK EDGE	D_A(1)	D_A(3)	D_A(5)	D_A(7)	D_A(9)	D_A(11)	D_A(13)	D_A(15)
0	0	2	4	6	8	10	12	14
1	32	34	36	38	40	42	44	46
2	64	66	68	70	72	74	76	78
3	96	98	100	102	104	106	108	110
4	1	3	5	7	9	11	13	15
5	33	35	37	39	41	43	45	47
6	65	67	69	71	73	75	77	79
7	97	99	101	103	105	107	109	111
8	128	130	132	134	136	138	140	142
9	160	162	164	166	168	170	172	174
10	192	194	196	198	200	202	204	206
11	224	226	228	230	232	234	236	238
12	129	131	133	135	137	139	141	143
13	161	163	165	167	169	171	173	175
14	193	195	197	199	201	203	205	207
15	225	227	229	231	233	235	237	239
16	256	258	260	262	264	266	268	270
17	288	290	292	294	296	298	300	302
18	320	322	324	326	328	330	332	334
19	352	354	356	358	360	362	364	366
20	257	259	261	263	265	267	269	271
21	289	291	293	295	297	299	301	303
22	321	323	325	327	329	331	333	335
23	353	355	357	359	361	363	365	367
24	384	386	388	390	392	394	396	398
25	416	418	420	422	424	426	428	430
26	448	450	452	454	456	458	460	462
27	480	482	484	486	488	490	492	494
28	385	387	389	391	393	395	397	399
29	417	419	421	423	425	427	429	431
30	449	451	453	455	457	459	461	463
31	481	483	485	487	489	491	493	495
32	512	514	516	518	520	522	524	526
33	544	546	548	550	552	554	556	558
34	576	578	580	582	584	586	588	590
35	608	610	612	614	616	618	620	622
36	513	515	517	519	521	523	525	527
37	545	547	549	551	553	555	557	559
38	577	579	581	583	585	587	589	591
39	609	611	613	615	617	619	621	623
40	640	642	644	646	648	650	652	654
41	672	674	676	678	680	682	684	686
42	704	706	708	710	712	714	716	718
43	736	738	740	742	744	746	748	750
44	641	643	645	647	649	651	653	655
45	673	675	677	679	681	683	685	687
46	705	707	709	711	713	715	717	719
47	737	739	741	743	745	747	749	751
48	768	770	772	774	776	778	780	782
49	800	802	804	806	808	810	812	814
50	832	834	836	838	840	842	844	846
51	864	866	868	870	872	874	876	878
52	769	771	773	775	777	779	781	783
53	801	803	805	807	809	811	813	815
54	833	835	837	839	841	843	845	847
55	865	867	869	871	873	875	877	879

Table 9. DLP650LNIR 2xLVDS DMD Data Pixel Mapping D_A(15,13,11,9,7,5,3,1) (continued)

DCCLK EDGE	D_A(1)	D_A(3)	D_A(5)	D_A(7)	D_A(9)	D_A(11)	D_A(13)	D_A(15)
56	896	898	900	902	904	906	908	910
57	928	930	832	934	936	938	940	942
58	960	962	964	966	968	970	972	974
59	992	994	996	998	1000	1002	1004	1006
60	897	899	901	903	905	907	909	911
61	929	931	933	935	937	939	941	943
62	961	963	965	967	969	971	973	975
63	993	995	997	999	1001	1003	1005	1007
64	1024	1026	1028	1030	1032	1034	1036	1038
65	1056	1058	1060	1062	1064	1066	1068	1070
66	1088	1090	1092	1094	1096	1098	1100	1102
67	1120	1122	1124	1126	1128	1130	1132	1134
68	1025	1027	1029	1031	1033	1035	1037	1039
69	1057	1059	1061	1063	1065	1067	1069	1071
70	1089	1091	1093	1095	1097	1099	1101	1103
71	1121	1123	1125	1127	1129	1131	1133	1135
72	1152	1154	1156	1158	1160	1162	1164	1166
73	1184	1186	1188	1190	1192	1194	1196	1198
74	1216	1218	1220	1222	1224	1226	1228	1230
75	1248	1250	1252	1254	1256	1258	1260	1262
76	1153	1155	1157	1159	1161	1163	1165	1167
77	1185	1187	1189	1191	1193	1195	1197	1199
78	1217	1219	1221	1223	1225	1227	1229	1231
79	1249	1251	1253	1255	1257	1259	1261	1263

Table 10. DLP650LNIR 2xLVDS DMD Data Pixel Mapping D_B(15,13,11,9,7,5,3,1)

DCLK EDGE	D_B(1)	D_B(3)	D_B(5)	D_B(7)	D_B(9)	D_B(11)	D_B(13)	D_B(15)
0	16	18	20	22	24	26	28	30
1	48	50	52	54	56	58	60	62
2	80	82	84	86	88	90	92	94
3	112	114	116	118	120	122	124	126
4	17	19	21	23	25	27	29	31
5	49	51	53	55	57	59	61	63
6	81	83	85	87	89	91	93	95
7	113	115	117	119	121	123	125	127
8	144	146	148	150	152	154	156	158
9	176	178	180	182	184	186	188	190
10	208	210	212	214	216	218	220	222
11	240	242	244	246	248	250	252	254
12	145	147	149	151	153	155	157	159
13	177	179	181	183	185	187	189	191
14	209	211	213	215	217	219	221	223
15	241	243	245	247	249	251	253	255
16	272	274	276	278	280	282	284	286
17	304	306	308	310	312	314	316	318
18	336	338	340	342	344	346	348	350
19	368	370	372	374	376	378	380	382
20	273	275	277	279	281	283	285	287
21	305	307	309	311	313	315	317	319
22	337	339	341	343	345	347	349	351
23	369	371	373	375	377	379	381	383
24	400	402	404	406	408	410	412	414
25	432	434	436	438	440	442	444	446
26	464	466	468	470	472	474	476	478
27	496	498	500	502	504	506	508	510
28	401	403	405	407	409	411	413	415
29	433	435	437	439	441	443	445	447
30	465	467	469	471	473	475	477	479
31	497	499	501	503	505	507	509	511
32	528	530	532	534	536	538	540	542
33	560	562	564	566	568	570	572	574
34	592	594	596	598	600	602	604	606
35	624	626	628	630	632	634	636	638
36	529	531	533	535	537	539	541	543
37	561	563	565	567	569	571	573	575
38	593	595	597	599	601	603	605	607
39	625	627	629	631	633	635	637	639
40	656	658	660	662	664	666	668	670
41	688	690	692	694	696	698	700	702
42	720	722	724	726	728	730	732	734
43	752	754	756	758	760	762	764	766
44	657	659	661	663	665	667	669	671
45	689	691	693	695	697	699	701	703
46	721	723	725	727	729	731	733	735
47	753	755	757	759	761	763	765	767
48	784	786	788	790	792	794	796	798
49	816	818	820	822	824	826	828	830
50	848	850	852	854	856	858	860	862
51	880	882	884	886	888	890	892	894
52	785	787	789	791	793	795	797	799
53	817	819	821	823	825	827	829	831
54	849	851	853	855	857	859	861	863
55	881	883	885	887	889	891	893	895

Table 10. DLP650LNIR 2xLVDS DMD Data Pixel Mapping D_B(15,13,11,9,7,5,3,1) (continued)

DCLK EDGE	D_B(1)	D_B(3)	D_B(5)	D_B(7)	D_B(9)	D_B(11)	D_B(13)	D_B(15)
56	912	914	916	918	920	922	924	926
57	944	946	948	950	952	954	956	958
58	976	978	980	982	984	986	988	990
59	1008	1010	1012	1014	1016	1018	1020	1022
60	913	915	917	919	921	923	925	927
61	945	947	949	951	953	955	957	959
62	977	979	981	983	985	987	989	991
63	1009	1011	1013	1015	1017	1019	1021	1023
64	1040	1042	1044	1046	1048	1050	1052	1054
65	1072	1074	1076	1078	1080	1082	1084	1086
66	1104	1106	1108	1110	1112	1114	1116	1118
67	1136	1138	1140	1142	1144	1146	1148	1150
68	1041	1043	1045	1047	1049	1051	1053	1055
69	1073	1075	1077	1079	1081	1083	1085	1087
70	1105	1107	1109	1111	1113	1115	1117	1119
71	1137	1139	1141	1143	1145	1147	1149	1151
72	1168	1170	1172	1174	1176	1178	1180	1182
73	1200	1202	1204	1206	1208	1210	1212	1214
74	1232	1234	1236	1238	1240	1242	1244	1246
75	1264	1266	1268	1270	1272	1274	1276	1278
76	1169	1171	1173	1175	1177	1179	1181	1183
77	1201	1203	1205	1207	1209	1211	1213	1215
78	1233	1235	1237	1239	1241	1243	1245	1247
79	1265	1267	1269	1271	1273	1275	1277	1279

8.3.2 Data Bus Operations

8.3.2.1 Row Addressing

The DIN (input data), DCLKIN (input data clock), and DVALID (data valid) signals enable the DLPC410 to capture one row of customer input data and send that data to the DMD. For the DMD to know specifically to which row the data will be applied, the ROW_MD(1:0) (row mode), the ROW_AD(10:0) (row address), and the NS_FLIP (North/South Flip) signal inputs must be presented to the DLPC410 inputs during each row cycle. [Table 11](#) shows the number of rows for each DMD supported by the DLPC410.

Table 11. DMD Row and Columns

TYPE	COLUMNS	ROWS	CLOCKS PER ROW	NO. OF DATA LINES
DLP650LNIR DMD	1280	800	40	16
DLP7000 and DLP7000UV DMDs	1024	768	16	32
DLP9500 and DLP9500UV DMDs	1920 (2048) ⁽¹⁾	1080	16	64

(1) The DLP9500 and DLP9500UV DMDs have 2048 memory cells per row. There are 64 bits at the beginning of each row and 64 bits at the end of each row which do not have corresponding DMD micromirrors. These 128 memory cells must be loaded with data but the data content can be arbitrary and will not affect the 1920 physical micromirrors within that row.

DMD data is loaded into the DMD SRAM pixels one row of data at a time. The DLP9500 and DLP9500UV require pattern data input to all four input data buses (A,B,C,D) while the DLP650LNIR, DLP7000 and DLP7000UV require pattern data to be input to two input data buses (A,B). The DLP650LNIR uses only the odd data bus pins of input buses A and B. The DMD input data buses are provided by the following DLPC410 outputs:

- DDC_DCLKOUT - high speed 2xLVDS data clock out to DMD
- SCTRL - high speed control bus to DMD
- DDC_DOUT[X:Y] - 2xLVDS data bus where X and Y depend on the DMD.

These signals are all output from the DLPC410 and are listed in [Pin Configuration and Functions](#). Data and control from the DLPC410 are clocked into the DMD on both the rising and falling edges of the DDR data clocks: DDC_DCLKOUT_[A, B] for the 2 input bus DMDs and DDC_DCLKOUT_[A, B, C, D] for the 4 input bus DMDs. Data loading does not cause mirror state changes - mirrors transition to the next state only when a Mirror Clocking Pulse (Reset) operation is performed.

The row load length in clocks can be determined by the following equation: number row clocks = number of pixels per row / (total data buses bit width × 2 edges per clock). The "2 edges per clock" in the denominator is a direct result of the Dual Data Rate (DDR) nature of the DMD input data bus. This equation yields the results shown in [Table 11](#)

The DMD incorporates single row write operations using a row address counter that has different modes of operation. These modes are dependent on the state of the ROW_MD, ROW_AD, and NS_FLIP input signals. As shown in [Table 12](#), ROW_MD(1:0) determines the row mode for a given Row Cycle, and, when ROW_MD = "10", then ROW_AD(10:0) selects the customer supplied single row address. ROW_MD and ROW_AD must be asserted and deasserted synchronously with DVALID and must be valid synchronous to the beginning of the data as shown in [Figure 9](#). If only one specific mode will be utilized in a customer system application, it is certainly acceptable to leave these values at their same desired input levels for as long as desired.

Row address orientation depends on the North/South Flip Flag (NS_FLIP) input to the DLPC410. This input controls if the DMD starting row address starts at the top of the DMD (Row 0) and increments downward, or from the bottom of the DMD (last row) and decrements upward.

The row address counter does not automatically wrap-around when using the increment row address pointer instructions. For example, after the final row is addressed, the row address pointer must be set to row 0.

Table 12. Row Modes and Row Addresses

ROW_MD(1:0)	ROW_AD(10:0) ⁽¹⁾	NS_FLIP ⁽²⁾	ACTION
"00"	"xxxxxxxxxx"	"x"	Row No-Op (No data write)
"01"	"xxxxxxxxxx"	0	Increment internal row address by '1' - write concurrent data into that row
"01"	"xxxxxxxxxx"	1	Decrement internal row address by '1' - write concurrent data into that row
"10"	ROW_AD(10:0)	"x"	Set Random row address as specified on ROW_AD(10:0) inputs - write concurrent data into that row.
"11"	"xxxxxxxxxx"	0	Set First row address (DMD Row 0) and write concurrent data into that row
"11"	"xxxxxxxxxx"	1	Set Last row address (DMD last row) - write concurrent data into that row (Last row = 767 for DP7000, 799 for DLP650LNIR, 1079 for DLP9500)

(1) "xxxxxxxxxx" and "x" are don't care situations.

(2) It is recommended NS_FLIP remain constant throughout the loading of the DMD and not change on a row cycle basis.

8.3.2.2 Single Row Write Operation

Once initialization is complete (INIT_ACTIVE = 0) the user is free to send data and control information to the DLPC410. When the user asserts the DVALID signal for the LVDS input buses, the DLPC410 samples the customer supplied binary input pattern data (DIN) as well as the Row Mode, Row Address, Block Mode, Block Address, and other control information. The DLPC410 then sends pattern data synchronously to the DMD along with row address and control information. The row cycle period is defined by the Clocks per Row in [Table 11](#) and is synchronous with DVALID as shown in [Figure 9](#). If DVALID is removed midway in a Row Cycle, the DLPC410 continues loading data regardless of data validity until the internal row cycle counter reaches the terminal count of Clocks/Row for that DMD.

[Figure 9](#) is an example of a single Row Cycle for the DLP7000 DMD. A total of 32 bits of input data are presented to the DLPC410 on each clock edge (16 bits on Bus A + 16 bits on Bus B) . An entire line must be written for data to be latched into DMD memory and it requires 16 DDR clock cycles to write a single row of 1024 bits.

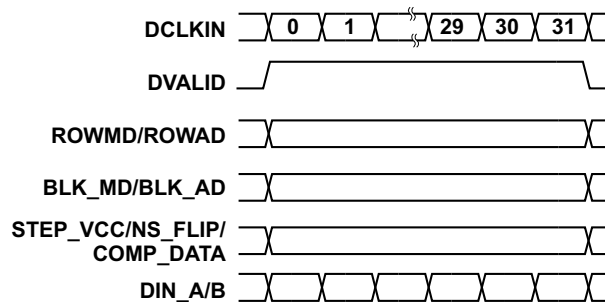

Figure 9. Single Row Write Operation (DLP7000 DMD)

8.3.2.3 No-Op Row Cycle Description

A Row No-Op is a row cycle in which setting ROW_MD = "00" commands the DLPC410 that within the current row cycle, no **Row Write** operation is to be performed. A Block No-Op is a row cycle in which BLK_MD = "00" commands the DLPC410 that within the current row cycle no **Block** Operation is to be performed. Row No-Ops can be inserted when only block operations are desired, Block No-ops can be inserted when only Row Write operations are desired, or both Row No-Ops and Block No-Ops can be performed at the same time when neither type of operation is desired (as shown in Figure 10). No-Ops are frequently inserted in the stream of data and commands when delays are desired to complete on-going operations to avoid violating delay requirements.

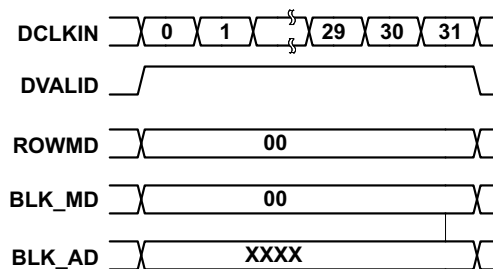

Figure 10. No-Op Row Cycle (DLP7000 example)

8.3.3 DMD Block Operations

Previous sections have described in detail how to send binary pattern data through the DLPC410 Controller to the connected DMD. Although the data loading process involves loading the specified data into the SRAM cells in the DMD array, this loading of data does not change the physical state of the DMD Micromirrors. The state of the mirrors can only be changed (or left the same if the data under the mirrors is unchanged) when a Mirror Clocking Pulse (Reset) is applied to the DMD MBRST pins from the DLPA200.

A sequence of Mirror Clocking Pulses (Resets) begins by asserting a row cycle with BLK_MD and BLK_AD as described in Table 14. Shortly after the row cycle, RST_ACTIVE output to the customer transitions to logic '1' for approximately 4.5 μ s indicating a Mirror Clocking Pulse operation is in progress. During this time, no additional Mirror Clocking Pulses may be initiated until RST_ACTIVE returns to logic '0'.

RST_ACTIVE does not return to logic '0' unless:

- data load row cycles are issued to other DMD blocks as in Figure 14 or,

- No-Op row cycles are provided to the DLPC410 to enable MCP or Block Clear operations to continue

This is accomplished by asserting DVALID while holding ROWMD = "00" and BLKMD = "00" for the pre-requisite number of CLKS per ROW (Table 11) clock cycles, as in Figure 10. If no other blocks need to be loaded then continuous No-Op row cycles are applied as in Figure 10 .

8.3.3.1 Mirror Clocking Pulse (MCP)

A Mirror Clocking Pulse is an analog voltage waveform provided to the DMD from the DLPA200 DMD Micromirror Driver. This waveform times the electrostatic forces which cause each micromirror to transition to its next state. This next state is determined by the data in the SRAM cell beneath each pixel. If the data has changed, the micromirror will rotate its position 24 degrees to the opposite state. If the data is unchanged, the mirror will remain in the same state. The DLPC410 instructs the DLPA200 to apply Mirror Clocking Pulses to the DLPA200 based on instructions from the user.

NOTE

A Mirror Clocking Pulse (MCP) is often referred to as a "Reset" operation.

8.3.3.2 Reset Active (RST_ACTIVE)

RST_ACTIVE is an output from the DLPC410 to indicate to the user that a user requested Reset (MCP) has been accepted by the DLPC410. Shortly after the user requests a Reset (MCP) by asserting the appropriate Block Control signals defined in [DMD Block Control Signals](#), RST_ACTIVE output to the user will transition to logic '1' for approximately 4.5 μ s indicating a Mirror Clocking Pulse operation is in progress. While RST_ACTIVE is logic '1', no additional Mirror Clocking Pulse requests may be initiated by the user until RST_ACTIVE returns to logic '0'. RST_ACTIVE is synchronized to a version of DCLKIN. As such, circuits in the application FPGA should consider this signal asynchronous and use standard synchronization techniques to assure reliable registering of this signal.

NOTE

After a Mirror Clocking Pulse or Clear command is given, RST_ACTIVE may not be asserted until up to 60ns after the command. During this time, no other command should be given.

8.3.3.3 DMD Block Control Signals

The DMD micromirrors and their corresponding SRAM pixels are organized into horizontal rows where data is loaded one row at a time. DMD Blocks are defined as a group of sequential rows of mirrors. Each mirror block is measured in groups of [ROWS per BLK] as described in [Table 11](#). DMD blocks are typically numbered from 0 to 15 with 0 being the block at the top of the DMD (row 0) and 15 being the block at the bottom of the DMD.

Table 13. DMD Block Characteristics

DMD TYPE	COLUMNS	ROWS	BLOCKS	ROWS PER BLOCK
DLP650LNIR DMD	1280	800	16	50
DLP7000 and DLP7000UV DMDs	1024	768	16	48
DLP9500 and DLP9500UV DMDs	1920	1080	15	72

8.3.3.3.1 Block Mode - BLK_MD1:0)

The Block Mode signals define the type of block operation the user would like to take place. The allowed operations which can be requested are defined in [Table 14](#). These signals work alongside the RST2BLK and the Block Address signals to provide the gamut of Block Operations that enable DMD mirrors to update to their next used desired state. These signals should be setup synchronously with the start of a row cycle.

8.3.3.3.2 Block Address - BLK_AD(3:0)

The Block Address signals help to specify which block or group of blocks will be acted upon in a user issued Block Operation. They work with the RST2BLK and Block Mode signals to indicate which block or group of blocks will see a Reset (MCP). These signals should be setup synchronously with the start of a row cycle.

8.3.3.3.3 Reset 2 Blocks - $\overline{\text{RST2BLK}}$

The Reset 2 Blocks ($\overline{\text{RST2BLK}}$) signal helps to signify a multiple block operation is requested by the user, where, depending on the state of $\overline{\text{RST2BLK}}$, either two blocks or 4 blocks will be Reset together. The specific blocks to be Reset will then be determined by the Block Mode and Block Address. This signal should be setup synchronously with the start of a row cycle.

NOTE

$\overline{\text{RST2BLK}}$ needs to be kept low during initialization for proper setup of the system. Dynamic changes to $\overline{\text{RST2BLK}}$ during normal operation are not recommended.

8.3.3.4 DMD Block Operations

Once a portion or all of the DMD is loaded with new data, the user typically requests a Block Operation to be performed. This operation causes the DLPC410 to initiate one of the many block related activities to a block or group of blocks to the DMD. Available Block operations are:

- **Block No-Op** - user requests via $\text{BLK_MD}(1:0) = "00"$ that no block operations are to take place in this row cycle. This is typically the case for row cycles used for data loading purposes only without any block operations.
- **Block Clear Request** - user requests a single block to be cleared causing all SRAM cells within that block to be reset to logic '0'.
- **Single Block Reset Request** - user requests a single DMD block be provided a Reset (MCP) signal to cause the micromirrors within that block to update to their new values.
- **Dual Block Reset Request** - user requests two sequential DMD blocks be provided Reset (MCP) signals to cause the micromirrors within those blocks to update to their new values.
- **Quad Block Reset Request** - user requests four sequential DMD blocks be provided Reset (MCP) signals to cause the micromirrors within those blocks to update to their new values.
- **Global Reset Request** - user requests all DMD blocks be provided Reset (MCP) signals to cause all DMD micromirrors to update to their new values.
- **DMD Park (Float) Request** - user requests all DMD micromirrors be provided special Parking Reset (MCP) signals causing the micromirrors within those blocks to relax to their unbiased state. This request is intended to place the micromirrors in the Parked state prior to power removal (shutdown).

Mirror blocks are addressed using the Block Address ($\text{BLK_AD}[3:0]$) signals for application of either a Mirror Clocking Pulse (Reset) or a Memory Clear operation by asserting the block control signals of [Table 14](#) at the start of each row data load. $\overline{\text{RST2BLK}}$, Block Mode ($\text{BLK_MD}[1:0]$), and $\text{BLK_AD}[3:0]$ define the requested operation as shown in [Table 14](#) and designate which mirror block or mirror blocks are issued a Mirror Clocking Pulse or are Cleared. The number of DMD blocks and BLOCKS/ROW is unique to each DMD - refer to the individual DMD data sheets for DMD block definition.

Table 14. Block Control Signals and Operations

RST2BLK	BLK_MD(1:0)	BLK_AD(3:0)	OPERATION	OPERATION TYPE
x	00	xxxx	None	Block No-OP
x	01	0000	Clear block 00	Block Clear Request ⁽¹⁾⁽²⁾
x	01	0001	Clear block 01	
x	01	0010	Clear block 02	
x	01	0011	Clear block 03	
x	01	0100	Clear block 04	
x	01	0101	Clear block 05	
x	01	0110	Clear block 06	
x	01	0111	Clear block 07	
x	01	1000	Clear block 08	
x	01	1001	Clear block 09	
x	01	1010	Clear block 10	
x	01	1011	Clear block 11	
x	01	1100	Clear block 12	
x	01	1101	Clear block 13	
x	01	1110	Clear block 14	
x	01	1111	Clear block 15	
x	10	0000	Reset block 00	Single Block Reset Request
x	10	0001	Reset block 01	
x	10	0010	Reset block 02	
x	10	0011	Reset block 03	
x	10	0100	Reset block 04	
x	10	0101	Reset block 05	
x	10	0110	Reset block 06	
x	10	0111	Reset block 07	
x	10	1000	Reset block 08	
x	10	1001	Reset block 09	
x	10	1010	Reset block 10	
x	10	1011	Reset block 11	
x	10	1100	Reset block 12	
x	10	1101	Reset block 13	
x	10	1110	Reset block 14	
x	10	1111	Reset block 15	
0	11	0000	Reset blocks 00-01	Dual Block Reset Request
0	11	0001	Reset blocks 02-03	
0	11	0010	Reset blocks 04-05	
0	11	0011	Reset blocks 06-07	
0	11	0100	Reset blocks 08-09	
0	11	0101	Reset blocks 10-11	
0	11	0110	Reset blocks 12-13	
0	11	0111	Reset blocks 14-15	
1	11	000x	Reset blocks 00-03	Quad Block Reset Request
1	11	001x	Reset blocks 04-07	
1	11	010x	Reset blocks 08-11	
1	11	011x	Reset blocks 12-15	
x	11	10xx	Reset blocks 00-15	Global Reset Request
x	11	11xx	Float blocks 00-15	DMD Park Request

- (1) Each Block Clear operation for DLP650LNIR and DLP7000(UV) DMDs will clear all SRAM cells of one DMD block (reset to '0') within one row cycle duration.
- (2) Each Block Clear operation for DLP9500(UV) DMDs must be followed by two No-Op row cycles. To clear one DMD Block, one Block Clear Request row cycle followed by two consecutive No Op row cycles are required. In total, 15 Block Clear Request row cycles and 30 No-Ops are required to clear the entire 15 block DMD array.

Block operations cause the DMD micromirrors to transition to their next state. Some notes and restrictions regarding block operations are:

- A Block No-Op row cycle causes no new block operations to occur. Block No-Op row cycles can be used to provide extended time for a previous operation.
- The Block Clear operation resets all SRAM pixels in the designated block to logic zero during the current row cycle.
- It is not necessary to Clear a block if it will be reloaded with new data (just like a normal memory cell).
- It is not possible to Clear a block while writing to a different block.
- It is possible to issue a Mirror Clocking Pulse to a block while data loading a different block.
- The DLP9500 and DLP9500UV DMDs have 15 blocks (block 0 – block 14). Block operations on block 15 have no function for this DMD.
- $\overline{\text{RST2BLK}}$ should be set to one value and not adjusted during normal system operation. A change in $\overline{\text{RST2BLK}}$ is not immediately effective and will require more than one row load cycle to complete.

8.3.3.4.1 Global Reset (MCP) Consideration

A Global Reset ($\text{BLK_MD} = 11$ and $\text{BLK_AD} = 10\text{XX}$) is an operation which Resets (MCP) all DMD blocks at the same time. The Global Reset duration is the same as the Single, Dual, and Quad Block Reset (MCP). In addition to requiring a No-Op row cycle to initiate the Global Reset, row cycles (either No-Op row cycles or data loading row cycles) are required to continually be provided to complete the Global Reset operation. If continual provision of row cycles is not provided, the customer interface monitoring RST_ACTIVE may never see RST_ACTIVE transition back low to indicate the Reset is complete. Customers should always provide valid row cycles, either No-Ops or data loading row cycles. To know when the reset operation is complete, customers can either monitor RST_ACTIVE high-to-low transition, or use a counter to know when at least a 4.5 μs period has expired from the start of the Global Reset. From that point on, the customer also needs to count the mirror settling time of the DMD to expire prior to loading the next data into the DMD.

NOTE

Reset (MCP) operations to a specific block or consecutive blocks of the DMD are also referred to "Block Resets" or just "Reset" operations. This is because they are physically "resetting" the micromirrors of the block to their next physical positions based on the underlying data.

NOTE

(DLP9500 and DLP9500UV DMDs Only) To clear one Mirror Clocking Pulse (Reset) Group in the DMD Block, one Clear command followed by two consecutive No Operation commands (No-Ops) are required. Therefore, 15 total Block Clear commands and 30 total No-Ops commands are required to clear the entire DMD array.

8.3.4 Other Data Control Inputs

It is recommended that the Complement and Flip flags be set to one value and not adjusted during normal system operation. These controls are asserted through a different mechanism than the input data bus and row controls, hence their effect is asynchronous and cannot be expected to take effect immediately upon assertion.

8.3.4.1 Complement Data

By setting the COMP_DATA flag high, the user is able to command the DMD to internally complement its data inputs prior to loading the data into the mirror array. At least 0.6 ms is needed for the signal to be loaded. This signal should not be used to invert data on a row basis. When used with the "Clear" command, the mirrors are still set to zero regardless of the COMP_DATA bit. The COMP_DATA signal should be kept low during initialization to ensure proper setup of the system.

8.3.4.2 North/South Flip

NS_FLIP allows the user to specify the loading direction of rows in the DMD when used with $\text{ROWMD} = "01"$. This control has no effect if $\text{ROWMD} = "10"$.

Row Addressing and Table 12 describe the effect of N/S flip. If NS_FLIP is set, this does not reverse the direction of Mirror Clocking Pulse groups (blocks). For example, the normal case is to Mirror Clocking Pulse blocks 0 – 15 in order. When NS_FLIP is set, the order of block Mirror Clocking Pulses must be reversed to 15 – 0.

The NS_FLIP signal should be kept low during initialization to ensure proper setup of the system.

8.3.5 Miscellaneous Control Inputs

8.3.5.1 \overline{ARST}

\overline{ARST} is an active low, asynchronous reset. This reset can be sourced from a voltage supervisor or from the customer interface. Be aware that the chipset will not operate correctly if all DLPC410 power supplies are not in range at the time this reset is released.

8.3.5.2 CLKIN_R

The reference clock, CLKIN_R, supplied from an oscillator must be 50 MHz. This is required for precise timing used to perform the DMD Mirror Clocking Pulse (Reset). This clock should be valid prior to releasing \overline{ARST} .

8.3.5.3 DMD_A_RESET

DMD_A_RESET is an active low reset to the DMD. This signal is deasserted as appropriate at the end of system initialization.

8.3.5.4 Watchdog Timer Enable ($\overline{WDT_ENABLE}$)

The DLPC410 contains a watchdog timer that initiates a global DMD Mirror Clocking Pulse in the event that the DMD has not received any Mirror Clocking Pulse by the user within the last 10 seconds. This auto-generated Mirror Clocking Pulse function is to provide Mirror Clocking Pulses to the DMD mirrors to prevent long term landed mirrors in the event the input data and source control has been inadvertently disrupted. This capability can be user disabled by setting WDT_ENABLE to logic '1'. Note that the global DMD Mirror Clocking Pulse generated by the watch dog timer is asynchronous to any/all activity on the DMD input data bus - therefore there is no guarantee as to the validity of the data displayed on the DMD once this pulse occurs, at least until new data is subsequently loaded and displayed.

8.3.6 Miscellaneous Status Outputs

8.3.6.1 INIT_ACTIVE

The INIT_ACTIVE signal ins an output which indicates that the DMD, Digital Micromirror Driver, and the Digital Controller are in an initialization state after power is applied. During this initialization period, the DLPC410 is calibrating the data interface, initializing the DMD, and DLPA200(s). When this signal goes low, the system has completed initialization. See the section on System initialization

8.3.6.2 DMD_Type(3:0)

The DLPC410 only supports the DMDs indicated in Table 15. At power-up, the DLPC410 checks the DMD signature. If the DLPC410 finds the DMD is not supported, it will not allow the user to display data on the DMD and indicated that the DMD is unsupported.

DMD_TYPE(3:0) is an output from the DLPC410 to the user FPGA which will indicate to the user which DMD is connected to the DLPC410, or in another case, the DMD is not supported or a DMD is not properly connected.

Table 15. DMD Characteristics

DMD_TYPE(3:0)	DMD Reported
0000	DLP9500 and DLP9500UV DMDs
0001	DLP7000 and DLP7000UV DMDs
0111	DLP650LNIR DMD
1111	Unsupported DMD / No DMD

8.3.6.3 DDC_VERSION(2:0)

These three pins identify the version of the DLPC410 determined by the contents of DLPR410. If a problem is encountered which encourages you to contact a Texas Instruments representative, please provide the version number along with the detailed information of the problem. See the DLPR410 datasheet ([DLPS027](#)) for the version number reported on these pins.

8.3.6.4 LED0

The LED0 signal is typically connected to an LED to show that the DLPC410 is operating normally. The signal is 1 Hz with 50% duty cycle, otherwise known as the heartbeat.

8.3.6.5 LED1

The LED1 signal is typically connected to an LED indicator to show the status of system initialization and the status of the clock circuits. The LED1 signal is asserted only when system initialization is complete and clock circuits are initialized. Logically, these signals are ANDed together to show an indication of the health of the system. If the Phase Locked Loop (PLL) connected to the data clock and the DMD clock are functioning correctly after system initialization, the LED will be illuminated.

8.3.6.6 DLPA200 Control Signals

Coordinating the operation of the DLPA200 with the DMD is one of the primary functions of the DLPC410. During system initialization, the DLPC410 releases the reset pin (DAD_INIT) and communicates with the DLPA200 via a serial bus to configure the device. Once this is complete, the high voltage output pins are enabled to prepare for command execution. As the DLPC410 is commanded to load data and perform Mirror Clocking Pulses, the DAD_ADDR address, DAD_MODE mode, DAD_SEL select and DAD_STROBE strobe signals are asserted as appropriate to cause the Mirror Clocking Pulses. The operation of these signals are managed by the DLPC410 and, besides board layout and good design practices, should be of little concern to the end user.

8.3.6.7 ECM2M_TP_ (31:0)

These are reserved signals for test signal output. Do not drive these signals.

8.4 Device Functional Modes

The DLPC410 has one basic function which is to receive customer data at the inputs of the DLPC410 and deliver that data and any appropriate DMD control information to the DMD for displaying of binary patterns at very high speeds. The [Feature Description](#) section describes how binary pattern data is loaded into the DMD and ultimately where that data is displayed on the DMD. The following subsections describe the different display modes of operation of the DMD as enabled by the DLPC410.

8.4.1 DLPC410 Initialization and Training

8.4.1.1 Initialization

The INIT_ACTIVE signal indicates that the DMD, Digital Micromirror Driver, and the Digital Controller are in an initialization state after power is applied. During this initialization period, the DLPC410 is calibrating the data interface, initializing the DMD, and DLPA200(s). When this signal goes low, the system has completed initialization. System initialization takes approximately 220 ms to complete. Data and command row cycles must not be presented to the DLPC410 during the initialization. INIT_ACTIVE should be considered an asynchronous feedback signal to the user. Standard synchronization techniques should be applied. After initialization is complete, a delay of at least 64 DCLKIN clocks (on all input data buses being used) should be observed before the first DVALID is asserted on those data buses to ensure a clean start up process.

NOTE

Note: NS_FLIP, COMP_DATA, and RST2BLK signals should be kept low ('0') during initialization to ensure proper system setup.

8.4.1.2 Input Data Interface (DIN) Training

The DLPC410 detects the phase differences between the ½ speed clock (used in the customer device driving the LVDS data) and the internally generated ½ speed data clocks and automatically corrects their alignment. This is done by the customer FPGA supplying a simple repeating pattern on all of the data inputs while the INIT_ACTIVE output of the DLPC410 is high/active. The details of the training pattern are described below.

This is a simple block diagram of the training pattern insertion logic.

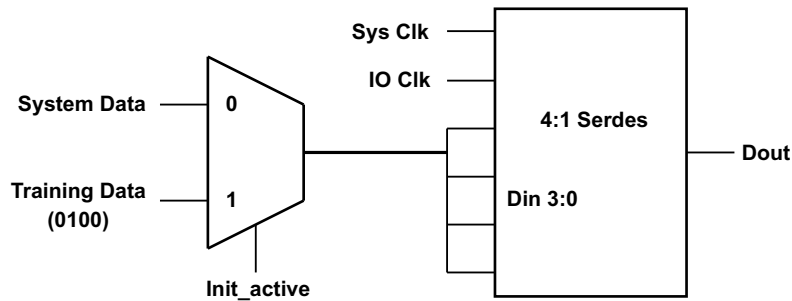

Figure 11. Block Diagram of Training Pattern Logic

The expected training pattern is 0100. In [Figure 12](#) the data input to the 4:1 SERDES cells is captured on the rising edge of the ½ speed system clock. The output latency shown is based on the documentation for the Xilinx SERDES cells. Individual implementation may vary depending on the type of cells, technology, and design technique used.

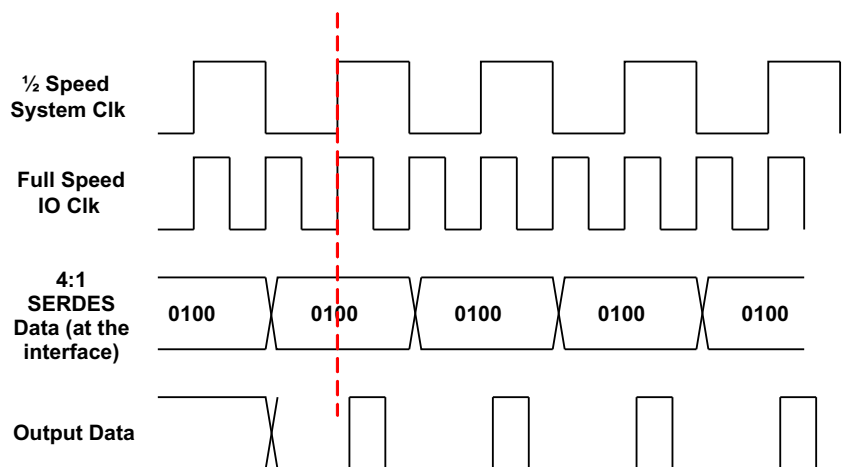

Figure 12. Training Pattern Alignment

NOTE

In Xilinx FPGAs (due to the construction of the ISERDES and OSERDES cells) a pattern of 0010 needs to be applied to the output/transmitting SERDES cells data pins (D1 = 0, D2 = 0, D3 = 1, D4 = 0) in order to receive a result of 0100 (Q1 = 0, Q2 = 1, Q3 = 0, Q4 = 0) at the input/receiving SERDES cell.

The patterns should be applied on all of the input data and DVALID pins. In this respect, the interface is treated as a 17 bit interface with DVALID being the 17th data bit. The receiving logic in the DLPC410 will shift the data until the correct pattern is seen at the inputs. The SERDES cells align the incoming data with the ½ speed system clock (derived from the full speed data clock). This allows DLPC410 to correctly align the DVALID signal and the incoming data and will contribute to a more robust interface. It is important that the training pattern is applied to the DVALID and data inputs of the DLPC410 before reset to the device is deasserted, as training commences immediately on the deassertion of reset. The INIT_ACTIVE signal is asserted while the device is held in reset in order to help facilitate this behavior.

8.4.2 DLPC410 Operational Modes

The following modes of operation are frequently used operational modes enabling customers to update DMD data and to control how, where, and how long their binary patterns are displayed on the DMD. Customers frequently pick the mode which provides the best performance and simplicity for their specific system. Combinations of these modes can also be used.

8.4.2.1 Single Block Mode

A single block of DMD memory cells can be updated by providing successive row cycles with valid data (DVALID) to the DLPC410 until the desired amount of data is presented. Since different DMDs have different row and block sizes (and therefore different number of clocks per row or per block), the amount of time it takes to load a block of DMD data will be different for each DMD. Leveraging [Table 11](#) and [Table 13](#), we can calculate the single block load time for each DMD by the following equation: Block Load Time = Clock Period × number CLKS per ROW × number ROWS per BLK. The results are shown in [Table 16](#) for DLPC410 supported DMDs.

Table 16. DMD Block Load Time (400 MHz DMD Clock)

DMD	DMD BLOCK LOAD TIME
DLP650LNIR	5.00 μsec
DLP7000 / DLP7000UV	1.92 μsec
DLP9500 / DLP9500UV	2.88 μsec

Once the block is loaded with data, a Block Reset (MCP) for that block must be initiated. This can be performed by providing a row cycle with BLKMD = "10" and with BLK_AD(3:0) equal to the block just loaded. Upon initiation of the Block Reset, RST_ACTIVE will transition high for approximately 4.5 μs indicating a Reset operation is taking place and that no additional Reset Requests will be accepted during that time. In the case of wanting to reload the same block with new data, one must wait for the 12.5 μs (RST_ACTIVE (4.5 μs) + the micromirror settling time (8 μs)) before the reload of the same block can start. Waiting this time allows for the DMD micromirrors in that block to settle to a stable state prior to reloading the memory cells underneath with new data. [Figure 13](#) shows a single block load, Mirror Clocking Pulse and reload sequence with the 8 μs periods indicating micromirror settling times.

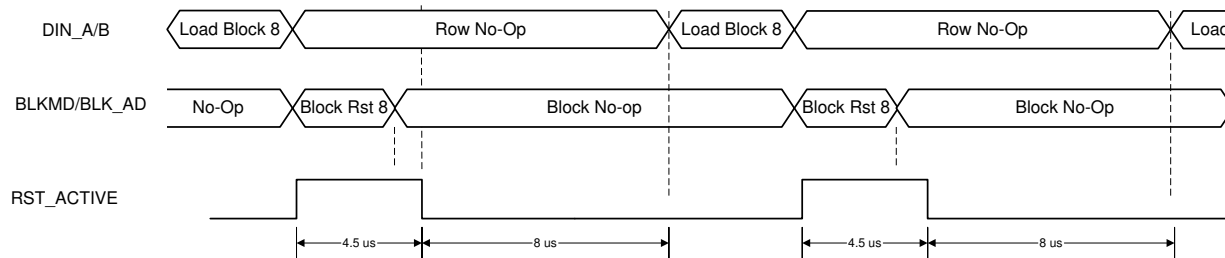

Figure 13. Block Load, Reset, and Same Block Reload

Although [Figure 13](#) shows that one must wait for the mirror settling time of the current block (Block=8 in this case) to complete before reloading data into the same block (8), it is possible to load data to a different block while waiting for Block 8 to settle. However, it must be a block which is not currently being Reset nor which has micromirrors which are still settling. This method is used in the Phased Mode of operation described in [Single Block Phased Mode](#).

NOTE

The RST_ACTIVE and micromirror settling times indicated in this example are typical for many DMDs. See each individual DMD data sheet for more information on the micromirror switching and settling times.

NOTE

Customers do not have to load the entire block at one time unless specifically directed. The DLPC410 supports individual row loads and partial block loads. Customers can use ROW_AD(10:0) to load one (or more) specific Row Addresses within any block. These loading modes are defined in [Table 12](#). Care must be taken to ensure all RST_ACTIVE time plus DMD mirror settling times are taken into account prior to re-loading any rows in the same block once a Reset has been requested.

8.4.2.2 Single Block Phased Mode

Single Block Phased Mode is best described as "phasing" the data load operation with the Block Reset operation. The major advantages of Phased Modes (Single, Dual, and Quad) in general are the idea of not having to wait for the micromirror settling time duration to complete prior to the next block reset, and for not having to wait for the Reset Request to complete prior to loading more data. In the example of [Figure 14](#), Block 15 is loaded with data while the Reset operation is taking place for Block 14 (Rst 14). The Reset Request (BLKMD and BLK_AD) for Block 14 needs to be one row cycle in duration minimum but can be extended to additional row cycles. Subsequent row cycles containing a valid Reset Request will be ignored until RST_ACTIVE goes low. Therefore, BLKMD and BLK_AD should transition from a Reset Request to a Block No-Op while RST_ACTIVE is still asserted as once RST_ACTIVE de-asserts there is the likelihood of an undesired Reset Request to be generated on the same block.

In [Figure 14](#), Block 0 is issued a Block Reset concurrently with data being loaded into the next block (1). The Row Cycles of the Block 1 data loading capture the Reset Request for Block 0, and provide continued Row Cycles for the duration of both the Block Load and the Block Reset. Note that the loading of block 1 does not need to wait for the mirror settling time of Block 0. This is repeated until the last block is Reset (which might also contain loading the next Block 0 data). Since the DLP650LNIR block load time is already longer than the RST_ACTIVE time, full utilization of its bandwidth is readily achieved in a single block phased mode.

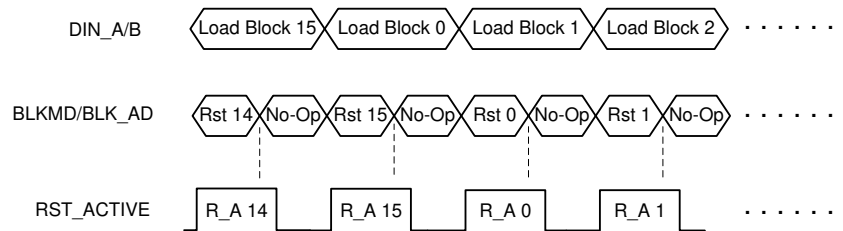

Figure 14. Single Block Phased Mode with Longer Block Load Times

Depending on the DMD type, the RST_ACTIVE duration of 4.5us may be longer than a single block load time. For example, the sequence shown in Figure 15 shows that when the Block Load time is shorter than RST_ACTIVE, one should include Row No-Ops to create a delay until the current RST_ACTIVE transitions low. Once RST_ACTIVE transitions low, the first row cycle of the next block data load can occur while also providing the Reset Request for the previously loaded block. At least one row cycle minimum must be completed to initiate the Reset Request and the next Reset Request must wait until the data is loaded and RST_ACTIVE transitions low.

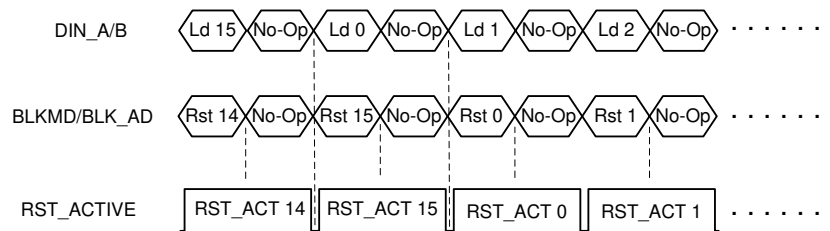

Figure 15. Single Block Phased Mode with Short Block Load Times

Figure 16 is nearly the same as Figure 16 except that the data loading of each block is timed such that it completes loading the block just about the same time the RST_ACTIVE signal goes low. Row No-Op cycles are used to provide the Reset Requests instead of data load row cycles. The benefit of this would be the delayed loading of data could provide more time for the customer application data processing upstream. In both cases, the next block Reset Request cannot be initiated until the previous Reset Request has completed.

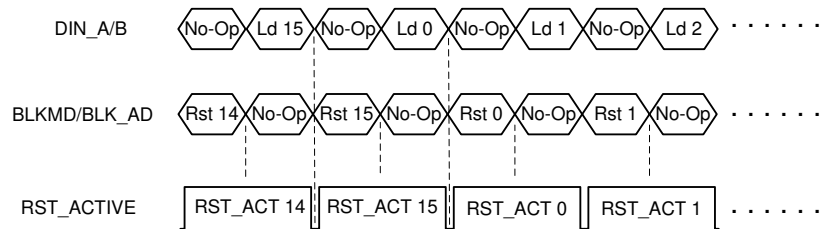

Figure 16. 2nd Single Block Phased Mode with Short Block Load Times

8.4.2.3 Dual Block Mode

Dual Block Mode can help to avoid the required delays (via No-Ops) encountered in a Single Phased Mode where the load time is less than the Reset duration. In the case of the DLP9500 DMD with a block load time of 2.88 μs, loading two blocks (2 × 2.88 = 5.76 μs) takes more time than the Reset duration (4.5 μs) so once the data is loaded, a Dual Block Reset Request can be issued immediately (instead of waiting for RST_ACTIVE) to the two blocks by setting RST2BLK to “0” and BLK_MD to “11” and the appropriate address in BLK_AD. This method is indicated in Figure 17.

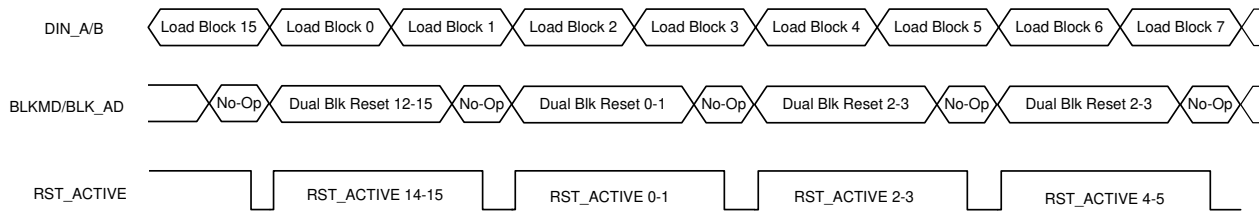

Figure 17. Dual Block Mode

8.4.2.4 Quad Block Mode

Quad Block mode is very similar to Dual Block mode but in Quad Block Mode, 4 Blocks are loaded with data and then Reset. In the case of the DLP7000 DMD with a block load time of 1.92 μs , the loading of two blocks would still be less than the 4.5 μs required for the Reset to complete so No-Ops would be required. To avoid inserting No-Ops in this case, loading four blocks ($4 \times 1.92 = 7.68 \mu\text{s}$) is longer than the RST_ACTIVE duration (4.5 μs) so once loaded, the 4 blocks can immediately be issued a Reset Request by ensuring RST2BLK = "1", BLK_MD = "11", and setting the appropriate BLK_AD address in the first row cycle of the next data block load.

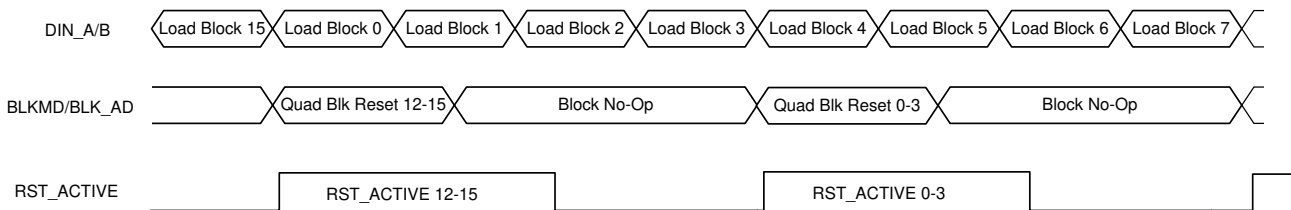

Figure 18. Quad Block Mode

Quad Block mode tends to offer customers the fastest full-DMD pattern rates combined with the largest solid state illuminations windows. Pattern rates for Single Block Phased and Dual Block Phased modes can sometimes be as fast as Quad Block rates, but the illumination windows can be smaller or even negative, thereby requiring delays between patterns to widen the illumination windows for solid state illuminators. These added delays will decrease the resulting pattern rates.

8.4.2.5 Global Mode

One of the simplest and most frequently utilized modes, the Global Mode involves loading the entire DMD with new pattern data and then issuing a Global Reset to update all DMD mirrors at the same time. Loading the entire DMD with data involves loading every row of every block. The time it takes to load the DMD is the block load time \times the number of blocks for that specific DMD. Table 17 shows the fastest DMD load times for DLPC410 supported DMDs.

Table 17. DMD Load Times (Entire DMD)

DMD	DMD LOAD TIME (400 MHz Clock)
DLP650LNIR	80.0 μsec
DLP7000 / DLP7000UV	30.7 μsec
DLP9500 / DLP9500UV	43.2 μsec

The Global Mode case is shown in [Figure 19](#). Following the loading of all rows in the device, a Row No-Op row cycle with a Global Reset Request must be issued to initiate the Reset Pulse and No-Ops should continue until ready to load the DMD again. If the global Reset Pulse is asserted prior to loading all rows of the device, rows which were not updated will show old data. Global mode is similar to [Single Block Mode](#) in that the mirror settling time must be taken into account prior to reloading the DMD data after a Reset Request is provided. This additional delay makes the Global Mode of operation inherently slower. However, if speed is not as important in a customer application, Global mode is great for its simplicity of DMD loading and Resetting.

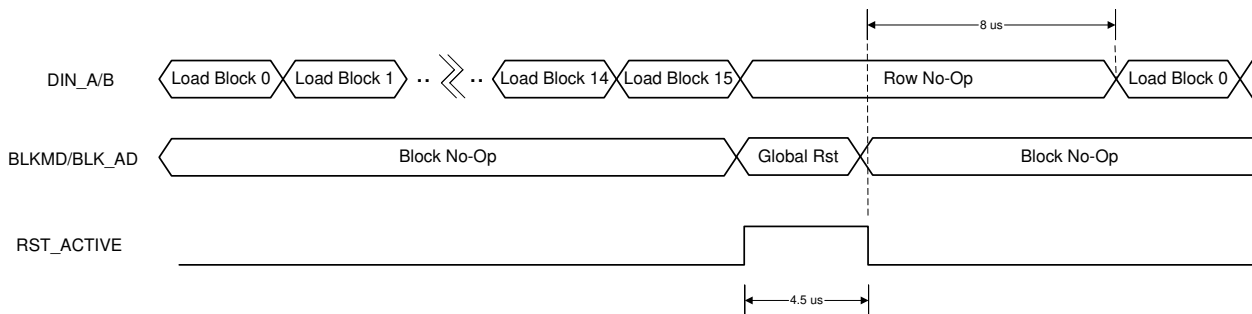

Figure 19. Full Device Load with Global Reset

8.4.2.6 DMD Park Mode

Park Mode places the DMD in a state where the micromirrors are not biased to either the plus or the minus side, but are instead floating in an unbiased and uncontrolled state. Hence, this is also referred to as Mirror Float mode. Parking (floating) the DMD mirrors should be performed when powering down the DMD to avoid leaving a static image on the DMD during down time or storage. The mirror can be Parked in one of two ways:

1. PWR_FLOAT input pin (recommended method) : asserting this input to the DLPC410 will cause the DLPC410 to automatically Park the mirrors in preparation for power removal. This operation is independent of any activity on the input data bus or Block operations. It is often best to drive this pin from both a power supervisor circuit which provides immediate DMD parking upon detecting input power removal, and from a programmable/controllable output from the customer application FPGA or processor.
2. DMD Park (Float Blocks 0-15) operation per [Table 14](#): A mirror float sequence begins with a row cycle with assertion of the proper BLK_MD and BLK_AD as described in [Table 14](#). Following the row cycle, the DMD releases the tension under each mirror so that all mirrors relax to a relatively flat position. The float operation takes approximately 3 μs to complete, during which time RST_ACTIVE is asserted.

NOTE

Park the DMD only when DC power is going to be removed from the DMD. Recovery from a PWR_FLOAT input pin assertion requires either a DLPC410 logic reset or a complete power cycle.

8.4.2.7 DMD Idle Mode

When not powering down the DMD yet it is desired to place the system in an idle (non-functioning) state, regardless of end application, all DMDs benefit from continuously operating the DMD near 50% landed on/off duty cycle. This requires customers to understand how they can provide the DMD a sequence of patterns which approximate a 50/50 duty cycle without interfering with normal operation of their system. See section 3 (Duty Cycle Considerations) in application note [DLPA052 - System Design Considerations Using TI DLP® Technology down to 400 nm](#). Also see

- [DLPA060 - System Design Considerations Using TI DLP® Technology in UVA](#), and
 - [DLPA104 - DLP® High-Power NIR Thermal Design Guide](#)
- for additional information.

8.4.3 LOAD4 Functionality (enabled with DLPR410A)

The DLPR410A PROM enables a new LOAD4 feature for the DLPC410 and attached DMD. The LOAD4 capability enables the DMD to load 4 rows for every row of data provided by the DLPC410, thereby reducing the number of rows to be transferred to 1/4 of the total of DMD rows, and the pattern load time to ¼ the total of row cycles, all at the expense of vertical resolution (1/4). Faster global binary pattern rates at the expense of vertical addressable resolution may make sense for certain applications like shutter/chopper solutions and vertical structured light patterns. LOAD4 reduces data load time only and does not reduce the “Mirror Clocking Pulse” and “Settling Time” durations.

8.4.3.1 Enabling LOAD4

LOAD4 is enabled by setting the DLPC410 input signal " $\overline{\text{LOAD4}}$ " to a logic '0'. When not using LOAD4, this input should be driven or pulled up to logic '1'.

NOTE

The $\overline{\text{LOAD4}}$ pin on the DLPC410 was previously defined as "DDC_SPARE_0" pin. DLPC410 reference schematics may still show this signal as DDC_SPARE_0 even though the DLPR410A enables the LOAD4 capability using this pin. LOAD4 capability is available starting with the DLPR410A and is not available with the DLPR410.

8.4.3.2 Loading Data with LOAD4

LOAD4 enables the attached DMD to load four rows of the same data for every one row of provided pattern data. “Automatic Increment” mode and “Row Address” mode can be used as before, however the largest addressable row will be the Vertical Resolution (VRes) of the attached DMD divided by four. For example, using LOAD4 the XGA DMD will have $1024/4 = 256$ addressable rows (0 . . . 255). The addressable vertical resolution is reduced by four, although the physical mirror resolution remains unchanged.

“Automatic Increment” address mode will automatically increment the Row Address input by one (or decrement by one for N/S flip). The Row Address input will be re-mapped as shown in the next section.

8.4.3.3 Row Mapping with LOAD4

The DMD row addresses are re-mapped per [Table 18](#).

Table 18. LOAD4 Row Address Mapping

Row Address Input	Physical Rows loaded on DMD
0	0, 1, 2, 3
1	4, 5, 6, 7
2	8, 9, 10, 11
3	12, 13, 14, 15
...	...
N	4N, 4N+1, 4N+2, 4N+3
...	...
(VRes/4) -1	VRes-4, VRes-3, VRes-2, VRes-1

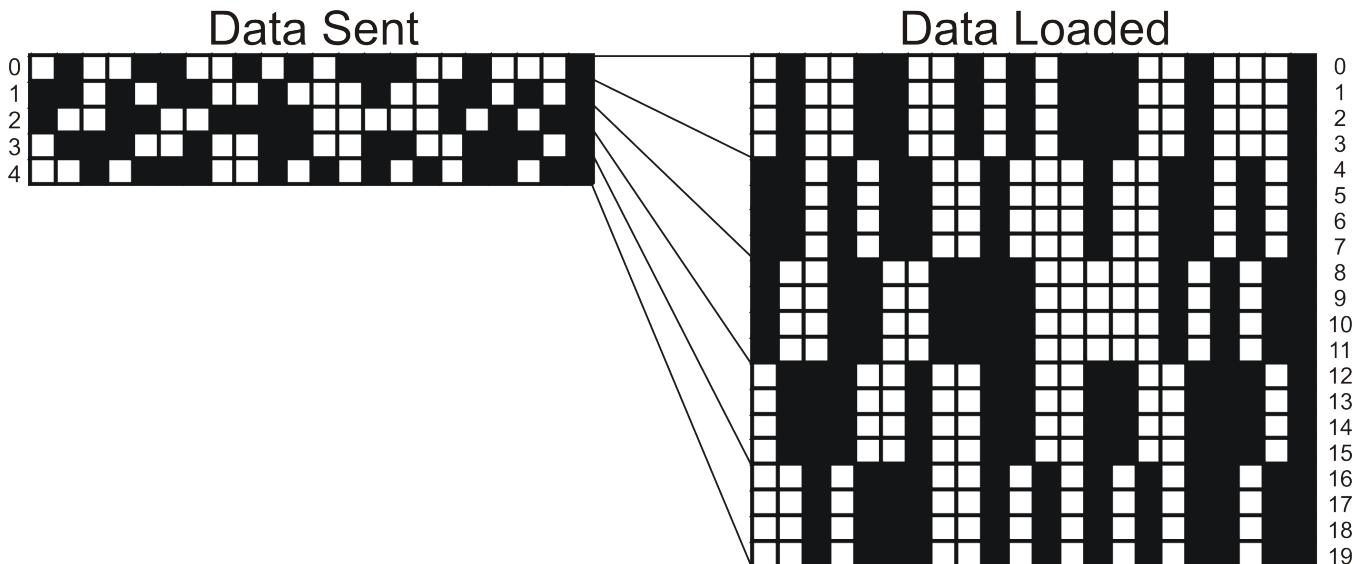

Figure 20. LOAD4 Row Address Mapping

8.4.3.4 Using Block Clear with LOAD4

While LOAD4 is enabled, Block Clear operations will be ignored. To use LOAD4 followed by Block Clear operations, simply de-assert LOAD4 at the beginning of the Reset request(s) preceding the Block Clear request(s). Re-assert LOAD4 at the beginning of the Reset request(s) preceding the next desired LOAD4 operation. This will ensure that the DLPC410 Controller has sufficient time to disable or enable LOAD4 before data is loaded or Block Clear(s) are requested.

8.4.3.5 Timing Requirements for LOAD4

LOAD4 functionality is primarily intended to be used with Global Resets. However, It is possible to use a subset of the DMD array including Block Resets. The driving software/hardware MUST ensure that the average “Reset” (MCP) rate does not exceed an average rate of 50,000 MCPs/sec as this is the specification limit of the [DLPA200 Micromirror Driver device](#). The driving software/hardware MUST also ensure that the “Mirror Settling Time” is not violated for any Block.

Average rate means averaged over 2-3 Load/Clear cycles. For example if a pattern is loaded and displayed with a Mirror Clocking Pulse followed by a Block Clear and a Mirror Clocking Pulse the “on” display time is very short. However, If the next pattern is loaded and displayed immediately, the average MCP rate may be exceeded, depending on the DMD and the number of Blocks in use. Therefore idle time must be added in the Load or Block Clear cycle to ensure an average MCP rate of 50,000 MCPs/sec or lower. Typically the smallest pattern display time is desired so that the time is added during the Load cycle rather than the Block Clear cycle so that the “off” time is extended, not the pattern display time.

8.4.3.6 Global Binary Pattern Rate increases using LOAD4

[Table 19](#) shows the improvements in binary pattern rates for the DLPC410 supported DMDs when using LOAD4 enhanced functionality of the DLPR410A PROM. When using solid state illuminators (which can be switched on and off quickly), the illumination window is the period of time between when a solid state illuminator can be turned on after the micromirrors have settled to when the micromirrors start to transition to their next state (after the load and a Reset). This illumination window is typically equal to the DMD load time. When the DMD load time is long (without LOAD4) there is a longer allowed illumination window for the application. As one moves to using LOAD4 but yet keeps the illumination window unchanged, the illumination window becomes a higher percentage of pattern period, and more the limiter of the maximum binary pattern rate.

Table 19. DMD Block Load Time at 400MHz DMD Clock

DMD	Global Frame Rate (without LOAD4)	Global Frame Rate (with LOAD4 mode)
DLP650LNIR	11k binary patterns/sec	30k binary patterns/sec
DLP7000	23k binary patterns/sec	48k binary patterns/sec
DLP9500	18k binary patterns/sec	42k binary patterns/sec

8.4.3.7 Special LOAD4 considerations

Take precautions when using LOAD4 mode with the DLP650LNIR DMD, or similar DMDs where the number of rows per reset block is not evenly divisible by 4. In the case of the DLP650LNIR, the number of rows per block for this DMD is 50 rows which is not evenly divisible by 4. Therefore, loading the last two rows of an even number block ($n = 0, 2, 4, \dots, 14$) concurrently loads the first two rows in the subsequent odd number block ($n+1$). Conversely, to address and load an odd block using LOAD4, the last two rows of the preceding even number block will be loaded first, else the first two rows of the odd block will not be loaded with new data.

8.5 Programming

The DLPC410 has no software interfaces and is therefore not programmable from a software perspective. All operational modes involve externally applied hardware signals.

9 Application and Implementation

NOTE

Information in the following applications sections is not part of the TI component specification, and TI does not warrant its accuracy or completeness. TI's customers are responsible for determining suitability of components for their purposes. Customers should validate and test their design implementation to confirm system functionality.

9.1 Application Information

The DLP650LNIR, DLP7000, DLP7000UV, DLP9500, and DLP9500UV devices require they be coupled with the DLPC410 controller to provide a reliable solution for many different applications. The DMDs are spatial light modulators which reflect incoming light from an illumination source to one of two directions, with the primary direction being into a projection collection optic. Each application is derived primarily from the optical architecture of the system and the format of the data coming into the DLPC410. Applications of interest include industrial, medical, and intelligent display.

9.1.1 Device Description

The DLPC410 Controller based chipsets offer developers a convenient way to design a wide variety of industrial, medical, and advanced display applications by delivering maximum flexibility in formatting and sequencing customer binary pattern data for display as projected light patterns from DMDs of varying resolutions.

These chipsets include the following components:

DLPC410 DMD Digital Controller

- Captures 2xLVDS input pattern data plus control from the user.
- Provides data and additional control to the DMD for high speed binary pattern display.
- Commands the DLPA200 to generate Resets Pulses (MCP) with highly specific timing.
- Supports random DMD row addressing, clear operations, and LOAD4 capability.

DLPR410 Configuration PROM

- Contains DLPC410 Controller power up configuration information.

DLPA200 DMD Micromirror Driver

- Creates Reset Pulses (MCP) to the DMD to initiate mirror transitions to the next state.

DMD: Digital Micromirror Device, a 2-dimensional array of aluminum micromirrors

- DMD micromirrors tilt +12 degrees and -12 degrees to steer light in one of two directions.
- DLP650LNIR DMD: 0.65-inch array diagonal, 1280 x 800 micromirror array, WXGA resolution.
- DLP7000(UV) DMDs: 0.7-inch array diagonal, 1024 x 768 micromirror array, XGA resolution.
- DLP9500(UV) DMDs: 0.95-inch array diagonal, 1920 x 1080 micromirror array, 1080p resolution.

Reliable function and operation of the DLP650LNIR, DLP7000, DLP7000UV, DLP9500, and DLP9500UV DMDs require the DMDs to be used in conjunction with the components listed in [Table 1](#). This document describes the proper integration and use of the chipset components.

The DLPC410 chipset can be combined with a user programmable Application FPGA (not included) to create high performance systems.

9.2 Typical Application

A typical embedded system application using the DLPC410 controller is shown in [Figure 21](#). The DLPC410, the DMD, and their associated DLP components do not specifically determine the application in which the components are used - customer applications and use cases may vary widely, from Digital Image Lithography to 3D Printing to 3D Scanners using Structured Light. The DMD is capable of being used with multiple illumination source types, from Lasers and LEDs to wide band wavelength mercury halide lamps. The DLPC410 supported DMDs cover applications utilizing ultraviolet (UV), visible, and/or near-infrared (NIR) wavelengths. The duration of each binary pattern displayed on the DMD is totally under control of the Applications Processor. The displayed patterns could be strictly binary patterns or could be bit weight exposures of varying durations representing

Typical Application (continued)

encoded PWM-based gray scales. The timing of the micromirrors and the illumination sources are controlled at the discretion of a Customer Applications Processor and in many solid state cases, provide best performance when source illuminators are synchronous to the commanded DMD micromirror transitions. The speed, diversity, programmability, and flexibility of the DLPC410 building blocks provide an electro-optical cornerstone for customers to build upon to create applications limited only by customer ingenuity.

In **Figure 21**, the MBRST 2 signals and the C, D LVDS Data buses are shown with dashed lines to indicate that some DMDs do not require these signals to be used. TI's Reference Design and Evaluation Modules leverage a DLPC410 Controller Board which supports all 5 of the DLPC410 supported DMDs. The performance differences for each application are determined by which DMD Board is plugged into the Controller Board. This provides a single DLPC410 design platform which can then be used for multiple customer SKUs within an application platform for product segmentation purposes.

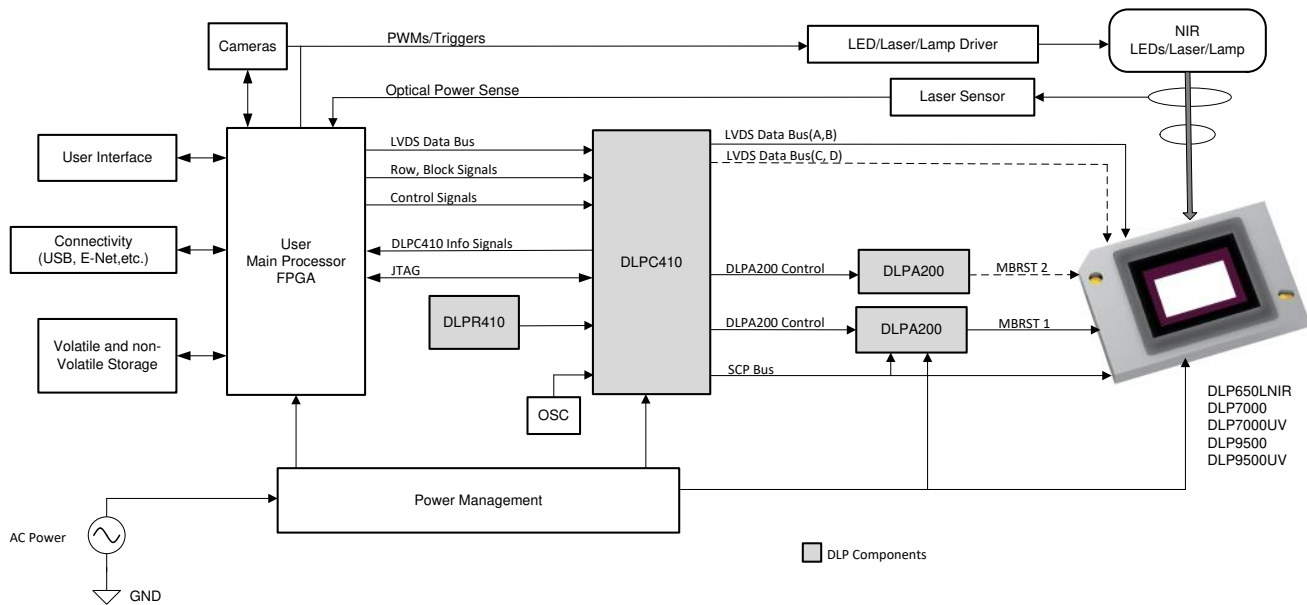

Figure 21. DLPC410 Application Example Block Diagram

9.2.1 Design Requirements

All applications using the DLP650LNIR, DLP7000(UV) or DLP9500(UV) DMDs require the DLPC410 Controller, DLPR410 PROM, and one or two DLPA200 Micromirror Drivers for proper operation. The chipset has several system interfaces and requires some support circuitry. The following interfaces and support circuitry for the DLPC410 are required:

- DLPC410 Application System Interfaces to the customer electronics and software:
 - Input LVDS Data Buses A, B, C, D
 - Row Address to specify DMD row to load
 - Block address and Block Mode to specify which DMD block(s) to "Reset" (MCP)
 - RST_ACTIVE feedback to indicated a "Reset" is in progress
 - Miscellaneous control inputs
 - Miscellaneous feedback signals
 - Power Supply inputs
- DLPC410 to other DLP Component Interfaces
 - Output LVDS Data Buses A, B, C, D to DMD
 - Output control signals (SCP bus) to DMD
 - Output commands to DLPA200 for MCP generation

Typical Application (continued)

9.2.2 Detailed Design Procedure

The DLP7000 and DLP9500 DMD are designed to be operated by the DLPC410 controller and are well suited for visible light applications requiring fast, spatially programmable light patterns using the micromirror array. In addition the DLP7000UV and DLP9500UV are well suited for direct imaging lithography, 3D printing applications, and other applications requiring ultraviolet light (UVA). The DLP650LNIR DMD is optimal for high power Near-Infrared light (NIR) applications like 3D additive manufacturing (SLS), marking and coding, and FPD repair and ablation. Refer to the [Functional Block Diagrams](#) to investigate the connections between the DLP650LNIR, DLP7000 / DLP7000UV or DLP9500 / DLP9500UV DMD, the DLPC410 digital controller, the DLPR410 Configuration PROM, and the DLPA200 DMD micromirror drivers. Layout guidelines should be followed for reliability.

9.2.3 Application Curves

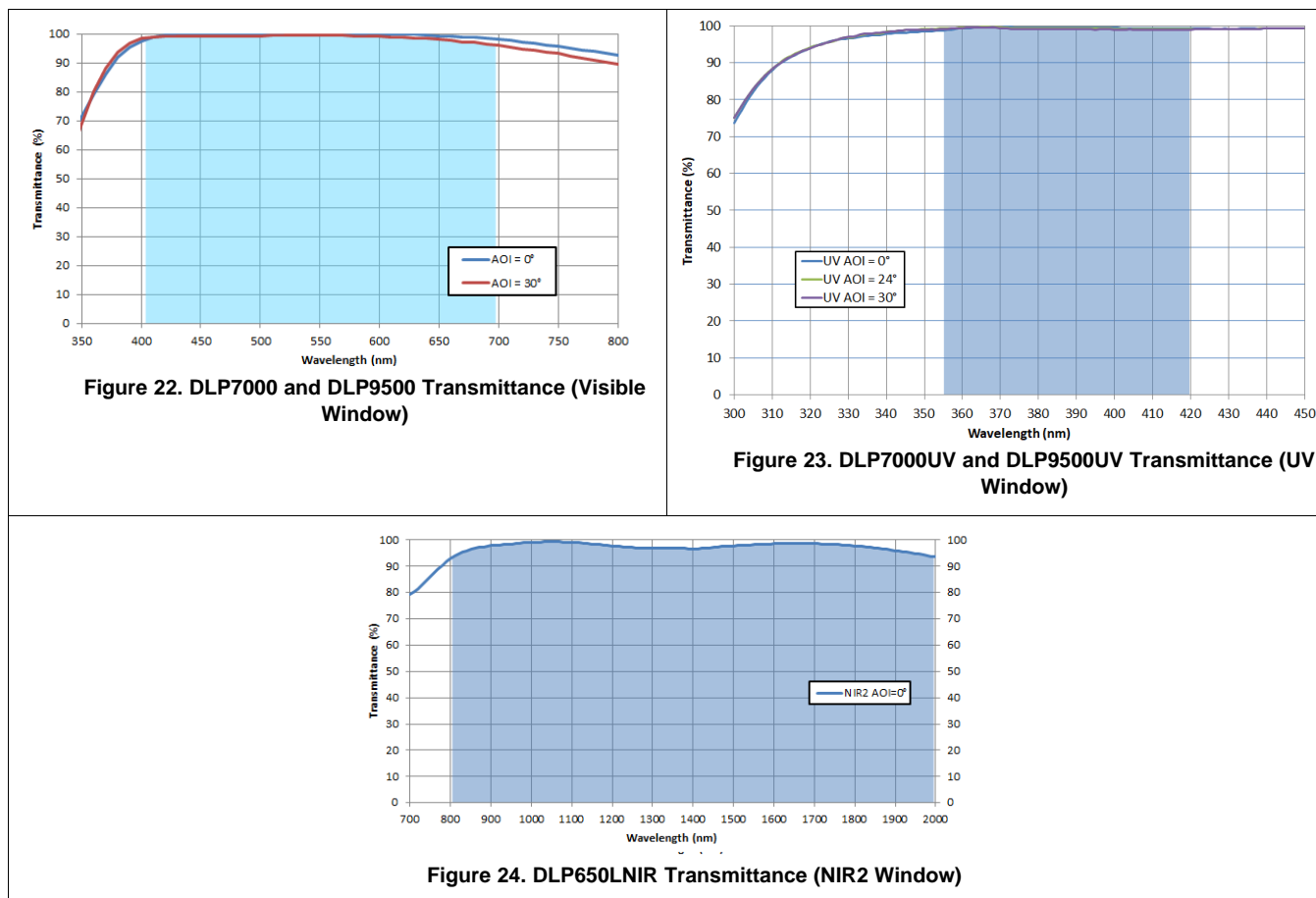

9.3 Initialization Setup

9.3.1 Debugging Guidelines

Prior to checking the DLPC410 output signals, make sure the reference clock to the DLPC410 is running at 50 MHz. Check that DONE_DDC (pin K10) signal is asserted and ECP2_Finished is de-asserted indicating the DLPR410 PROM has correctly programmed the DLPC410 Controller and the DLPC410 is running.

9.3.2 Initialization

Initialization will automatically start after $\overline{\text{ARST}}$ (pin AC13) is released (transition to '1'). The initialization process includes the following components:

Initialization Setup (continued)

1. Input Data Bus Calibration
2. DLPA200 Initialization Step 1
3. DMD Initialization
4. DLPA200 Initialization Step 2
5. Command Sequence

9.3.2.1 Input Data Bus Calibration

Calibration of the DLPC410 2xLVDS input data buses is performed on each of the data (DDC_DIN) and DVALID signal pairs of all input buses using the training pattern as specified in [Input Data Interface \(DIN\) Training](#). When this calibration is successful, the System Initialization process will move on to initializing the DLPA200 devices.

NOTE

The training pattern going into the SERDES on the transmit side is different than the pattern on the receive SERDES. On the receive side the value should be "0100". However, this could translate to "0010" on the transmit side. Please see [Input Data Interface \(DIN\) Training](#) for more information. An improper training pattern could cause the part to not perform the commands correctly.

9.3.2.2 DLPA200 Initialization Step 1

The DLPC410 will partially initialize both DLPA200 devices (1 and 2) such that all voltages to the DMD are at their proper initial state. The DLPC410 outputs $\overline{\text{DAD_A_SCPEN}}$ (pin AE3) and $\overline{\text{DAD_B_SCPEN}}$ (pin AB19) will assert indicating that the DLPC410 is ready to communicate with the DLPA200 devices. Signaling should be seen on SCPCLK (pin AB15), SCPDO (pin AA15 - SCP data output from the DLPC410) and SCPDI (pin AA15 - SCP data input to the DLPC410). During layout, ensure that the direction of the SCP data input and output signals are connected correctly.

9.3.2.3 DMD Initialization

During DMD initialization, the DLPC410 output $\overline{\text{DMD_A_SCPEN}}$ (pin AB14) signal will assert indicating that the DLPC410 is ready to communicate to the DMD. Signaling can be seen on SCPCLK (pin AB15), SCPDO (pin AA15 - SCP output from the DLPC410) and SCPDI (pin AA15 - SCP input to the DLPC410) lines. During layout, ensure that the direction of the SCP input and output signals are connected correctly.

9.3.2.3.1 DMD Device ID Check

If the DLPC410 has successfully initialized the DMD, the four DMD_TYPE(3:0) output pins (AA17, AC16, AB17, and AD15) of the DLPC410 will provide the DMD type as identified from the DMD during its initialization process. The possible DMD_TYPE values are shown in [Table 15](#). DMD_TYPE(3:0) will return "1111" if the DMD is not recognized, not attached, or if the DLPC910 is unable to communicate with the DMD.

NOTE

Only the DMDs listed in [Table 1](#) and [Table 15](#) are supported by the DLPC410. The DLPC410 will not function for unsupported DMDs or when a DMD is not installed.

9.3.2.4 DLPA200 Initialization Step 2

Now that the DMD ID has been assessed by the DLPC410, the Controller will finish the DLPA200 initialization to set the DLPA200 voltages to their final operating settings for the specific connected DMD. The DLPC410 outputs $\overline{\text{DAD_A_SCPEN}}$ (pin AE3) and $\overline{\text{DAD_B_SCPEN}}$ (pin AB19) will assert indicating that the DLPC410 is ready to communicate with the DLPA200 devices. Signaling should be seen on SCPCLK (pin AB15), SCPDO (pin AA15 - SCP data output from the DLPC410) and SCPDI (pin AA15 - SCP data input to the DLPC410). During layout, ensure that the direction of the SCP data input and output signals are connected correctly.

Initialization Setup (continued)

When DLPA200 initialization is complete, check V_{BIAS} , V_{RESET} , and V_{OFFSET} voltage values on both DLPA200 devices and compare against the DLPA200 data sheet specification and the DMD data sheet specification for the DMD connected to the DLPC410.

9.3.2.5 Command Sequence Initialization

The last portion of the initialization process involves a series of commands sent from the DLPC410 to the DMD. During this step, check the output pins (OUT[15:0]) of the DLPA200(s). One should expect to see several Mirror Clocking Pulse waveforms indicating the DLPA200s are initialized correctly.

This will complete the initialization process. When the initialization process starts, the INIT_ACTIVE output signal (pin AA18) will assert (go high) indicating that the initialization sequence is in process. At the end of the initialization sequence, if the initialization is successful, the INIT_ACTIVE output signal (pin AA18) will deassert (go low) indicating that the initialization process is complete.

NOTE

Initialization complete indicates that the initialization sequence of the DLPC410 has completed, but does not ensure that each step was completed correctly, only that it finished. For example the initialization of a DLPA200 may complete, but if the voltages set are incorrect further investigation is needed to uncover the reason.

9.3.3 Image Display Issues

There are three steps to displaying an image on the DMD, each of which can cause an image to fail to display correctly or in some case not at all. These steps are:

1. Present Data to DLPC410 – Pattern data generated by the user's device.
2. Load Data to the DMD – The DLPC410 loads data into the attached DMD CMOS memory array.
3. Issue Reset (MCP) – A Reset pulse (MCP) is issued to block(s) to change the state of the micromirrors based on the data loaded in step two. See [Mirror Clocking Pulse \(MCP\)](#).

9.3.3.1 Present Data to DLPC410

If there is a problem with the image displayed, one of the first places to check is the data being presented to the DLPC410. This data is generated by customer application hardware/software and is then presented to the inputs of the DLPC410. If the data is formatted incorrectly or the control information is incorrect, the DLPC410 may not properly receive the data. Please see [Row Addressing](#) for a description of how to send data to the DLPC410.

9.3.3.2 Load Data to DMD

After data and commands are sent to the DLPC410, the DLPC410 processes the information and passes it to the DMD. If there is no image displayed, first check the data output and SCTRL lines of the DLPC410 to see if there is data coming out. Data output (DDC_DOUT...) and DDC_SCTRL pins can be found in the [Pin Configuration and Functions](#).

PWR_FLOAT (pin AC17) will prevent the data from coming out of the DLPC410 if asserted. Check to make sure that it is at logic level 0.

A *Float blocks 00-15* command will also prevent data from the DLPC410. Please see the last entry of [Table 14](#).

9.3.3.3 Mirror Clocking Pulse

For a new image to appear on the DMD, Mirror Clocking Pulses must be received for the DMD block or blocks that have received new data. Check DAD_A_STROBE (pin AF3) and DAD_B_STROBE (pin AB20) [if applicable] for pulses to verify that requests for mirror clocking pulses are being sent to the DLPA200(s). Also check the DLPA200(s) output is enabled by checking that $\overline{DAD_OE}$ (pin AF5) is low.

10 Power Supply Recommendations

10.1 Power Down Operation

For correct operation of the DMD, the following power down procedure must be executed. Prior to power removal, assert PWR_FLOAT and allow approximately 300 μ s for the procedure to complete. This procedure will assure the mirrors are in a flat state, similar to the float operation. Following this procedure, the power can be safely removed.

To restart after assertion of PWR_FLOAT the DLPC410 must be reset ($\overline{\text{ARST}}$ low then high) or power must be cycled.

11 Layout

11.1 Layout Guidelines

The DLPC410 is part of a chipset that controls a DLP650LNIR, DLP7000 / DLP7000UV or DLP9500 / DLP9500UV DMD in conjunction with the DLPA200 driver(s). These guidelines are targeted at designing a PCB board with these components.

11.1.1 Impedance Requirements

Signals should be routed to have a matched impedance of 50 $\Omega \pm 10\%$ except for LVDS differential pairs (DMD_DAT_Xnn, DMD_DCKL_Xn, and DMD_SCTRL_Xn), which should be matched to 100 $\Omega \pm 10\%$ across each pair.

11.1.2 PCB Signal Routing

When designing a PCB board for the DLP650LNIR, DLPC7000 / DLP7000UV or DLP9500 / DLP9500UV controlled by the DLPC410 in conjunction with the DLPA200(s), the following are recommended:

Signal trace corners should be no sharper than 45°. Adjacent signal layers should have the predominate traces routed orthogonal to each other. TI recommends that critical signals be hand routed in the following order: DDR2 Memory, DMD (LVDS signals), then DLPA200 signals.

TI does not recommend signal routing on power or ground planes.

TI does not recommend ground plane slots.

High speed signal traces should not cross over slots in adjacent power and/or ground planes.

Table 20. Important Signal Trace Constraints

SIGNAL	CONSTRAINTS
LVDS (DMD_DAT_xnn, DMD_DCKL_xn, and DMD_SCTRL_xn)	P-to-N data, clock, and SCTRL: <10 mils (0.25 mm); Pair-to-pair <10 mils (0.25 mm); Bundle-to-bundle <2000 mils (50 mm, for example DMD_DAT_Ann to DMD_DAT_Bnn) Trace width: 4 mil (0.1 mm) Trace spacing: In ball field – 4 mil (0.11 mm); PCB etch – 14 mil (0.36 mm) Maximum recommended trace length <6 inches (150 mm)

Table 21. Power Trace Widths and Spacing

SIGNAL NAME	MINIMUM TRACE WIDTH	MINIMUM TRACE SPACING	LAYOUT REQUIREMENTS
GND	Maximize	5 mil (0.13 mm)	Maximize trace width to connecting pin as a minimum
P2P5V, P1P0V	50 mil (1.3 mm)	10 mil (0.25 mm)	Create mini planes and connect to devices as necessary with multiple vias
P2P5V, P1P0V	30 mil (0.76 mm) - stub width	10 mil (0.25 mm)	Stub width to connecting IC pins; maximize width when possible

11.1.3 Fiducials

Fiducials for automatic component insertion should be 0.05-inch copper with a 0.1-inch cutout (antipad). Fiducials for optical auto insertion are placed on three corners of both sides of the PCB.

11.1.4 PCB Layout Guidelines

A target impedance of 50 Ω for single ended signals and 100 Ω between LVDS signals (P/N) is specified for all signal layers.

11.1.4.1 DMD Interface

The digital interface from the DLPC410 to the DMD are LVDS signals that run at clock rates up to 400 MHz. DDR Data is clocked into the DMD on both the rising and falling edge of the clock, so the data rate is 800 MHz. The LVDS signals should have 100- Ω differential impedance. The differential signals should be matched but kept as short as possible. Parallel termination at the LVDS receiver is in the DMD; therefore, on board termination is not necessary.

11.1.4.1.1 Trace Length Matching

The require precise length matching. LVDS data bus differential pairs should have an impedance of 100 Ω (with 5% tolerance). It is important that the propagation delays are matched. The maximum differential pair uncoupled length is 150 mils with a relative propagation delay of ± 25 mil between the p and n. Matching all signals exactly will maximize the channel margin. The signal path through all boards, flex cables and internal DMD routing must be considered in this calculation.

11.1.4.2 DLPC410 DMD Decoupling

General decoupling capacitors for the DMD should be distributed around the PCB and placed to minimize the distance from IC voltage and ground pads. Each decoupling capacitor (0.1 μ F recommended) should have vias directly to the ground and power planes. Via sharing between components (discreet or integrated) is discouraged. The power and ground pads of the DMD should be tied to the voltage and ground planes with their own vias.

11.1.4.2.1 Decoupling Capacitors

Decoupling capacitors should be placed to minimize the distance from the decoupling capacitor to the supply and ground pin of the component. It is recommended that the placement of and routing for the decoupling capacitors meet the following guidelines:

- The supply voltage pin of the capacitor should be located close to the device supply voltage pin(s). The decoupling capacitor should have vias to ground and voltage planes. The device can be connected directly to the decoupling capacitor (no via) if the trace length is less than 0.1 inch. Otherwise, the component should be tied to the voltage or ground plane through separate vias.
- The trace lengths of the voltage and ground connections for decoupling capacitors and components should be less than 0.1 inch to minimize inductance.
- The trace width of the power and ground connection to decoupling capacitors and components should be as wide as possible to minimize inductance.
- Connecting decoupling capacitors to ground and power planes through multiple vias can reduce inductance and improve noise performance.
- Decoupling performance can be improved by utilizing low ESR and low ESL capacitors.

11.1.4.3 VCC and VCC2

The VCC pins of the DMD should be connected directly to the DMD VCC plane. Decoupling for the VCC should be distributed around the DMD and placed to minimize the distance from the voltage and ground pads. Each decoupling capacitor should have vias directly connected to the ground and power planes. The VCC and GND pads of the DMD should be tied to the VCC and ground planes with their own vias.

The VCC2 voltage can be routed to the DMD as a trace. Decoupling capacitors should be placed to minimize the distance from the VCC2 and ground pads of the DMD. Using wide etch from the decoupling capacitors to the DMD connection will reduce inductance and improve decoupling performance.

11.1.4.4 DMD Layout

See the respective sections in this data sheet for package dimensions, timing and pin out information.

11.1.4.5 DLPA200

The DLPA200 generates the micromirror clocking pulses for the DMD. The DMD-drive outputs from the DLPA200 should be routed with minimum trace width of 11 mil and a minimum spacing of 15 mil. The VCC and VCC2 traces from the output capacitors to the DLPA200 should also be routed with a minimum trace width and spacing of 11 mil and 15 mil, respectively. See the DLPA200 customer data sheet for mechanical package and layout information.

11.2 Layout Example

For LVDS (and other differential signal) pairs and groups, it is important to match trace lengths. In the area of the dashed lines, [Figure 25](#) shows correct matching of signal pair lengths with serpentine sections to maintain the correct impedance.

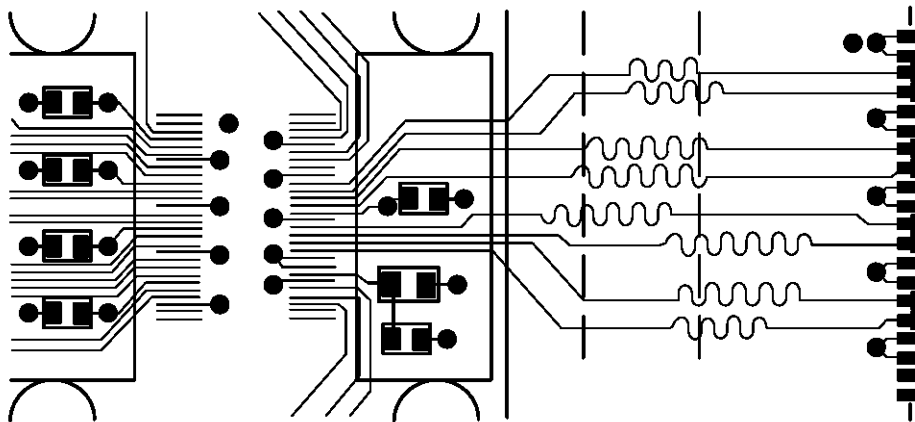

Figure 25. Mitering LVDS Traces to Match Lengths

11.3 DLPC410 Chipset Connections

The following tables list the signal connections between components of the Chipset when used with the DLP650LNIR DMD, the DLP7000 / DLP700UV DMD, and with the DLP9500 / DLP9500UV DMD. These tables do not include power, ground, pull-up, pull-down, termination, or any other connection requirements. Please see the Pin Functions table in the respective data sheet of each chipset component for connection requirements.

Table 22. DLPC410 Chipset Connections with the DLP650LNIR

DLPC410 (CONTROLLER)		DLPR410 (PROM)		DLPA200 (MICROMIRROR DRIVER)		DLP650LNIR (DMD)	
PIN		PIN		PIN		PIN	
NAME	NO.	NAME	NO.	NAME	NO.	NAME	NO.
DONE_DDC	K10	\overline{CE}	B4				
INTB_DDC	J11	OE/\overline{RESET}	A3				
PROGB_DDC	J18	\overline{CF}	D1				
PROM_CCK_DDC	J10	CLKOUT	C2				
PROM_D0_DDC	K11	D0	H6				
TCK_JTAG	U11	TCK	H3				
TDO_XCF16DDC	V11	TDO	E6				
TMS_JTAG	V12	TMS	E2				
DAD_A_ADDR0	E1			ADDR0	19		
DAD_A_ADDR1	E2			ADDR1	18		
DAD_A_ADDR2	E3			ADDR2	17		
DAD_A_ADDR3	F3			ADDR3	16		
DAD_A_MODE0	C1			MODE0	3		
DAD_A_MODE1	D1			MODE1	2		
DAD_A_SEL0	AB12			SEL0	5		
DAD_A_SEL1	AC12			SEL1	4		
DAD_A_STROBE	AF3			STROBE	15		
DAD_INIT	AF4			\overline{RESET}	59		
$\overline{DAD_OE}$	AF5			\overline{OE}	6		
$\overline{DAD_A_SCPEN}$	AE3			\overline{SCPEN}	58		
SCPCLK	AB15			SCPCLK	56	SCPCLK	E3
SCPDI	AA15			SCPDO	57	SCPDO	B2
SCPDO	AA14			SCPDI	42	SCPDI	F4
$\overline{DMD_A_SCPEN}$	AB14					\overline{SCPEN}	D4
DMD_A_RESET	AD14					\overline{PWRDN}	C3
DDC_DCLKOUT_A_DPN	N1					DCLK_AN	B22
DDC_DCLKOUT_A_DPP	M1					DCLK_AP	B24
DDC_DCLKOUT_B_DPN	Y5					DCLK_BN	AB22
DDC_DCLKOUT_B_DPP	Y6					DCLK_BP	AB24
DDC_DOUT_A1_DPN	AD1					D_AN(1)	A13
DDC_DOUT_A1_DPP	AE1					D_AP(1)	A11
DDC_DOUT_A3_DPN	AB1					D_AN(3)	C17
DDC_DOUT_A3_DPP	AB2					D_AP(3)	C15
DDC_DOUT_A5_DPN	W1					D_AN(5)	A17
DDC_DOUT_A5_DPP	Y1					D_AP(5)	A19
DDC_DOUT_A7_DPN	U1					D_AN(7)	D22
DDC_DOUT_A7_DPP	U2					D_AP(7)	D20
DDC_DOUT_A9_DPN	N2					D_AN(9)	D28
DDC_DOUT_A9_DPP	M2					D_AP(9)	B28

DLPC410 Chipset Connections (continued)
Table 22. DLPC410 Chipset Connections with the DLP650LNIR (continued)

DLPC410 (CONTROLLER)		DLPR410 (PROM)		DLPA200 (MICROMIRROR DRIVER)		DLP650LNIR (DMD)	
PIN		PIN		PIN		PIN	
NAME	NO.	NAME	NO.	NAME	NO.	NAME	NO.
DDC_DOUT_A11_DPN	K2					D_AN(11)	F26
DDC_DOUT_A11_DPP	K3					D_AP(11)	D26
DDC_DOUT_A13_DPN	H2					D_AN(13)	H28
DDC_DOUT_A13_DPP	J1					D_AP(13)	H30
DDC_DOUT_A15_DPN	G2					D_AN(15)	K26
DDC_DOUT_A15_DPP	F2					D_AP(15)	K28
DDC_DOUT_B1_DPN	AD3					D_BN(1)	AC13
DDC_DOUT_B1_DPP	AD4					D_BP(1)	AC11
DDC_DOUT_B3_DPN	AC3					D_BN(3)	AA17
DDC_DOUT_B3_DPP	AC4					D_BP(3)	AA15
DDC_DOUT_B5_DPN	AB7					D_BN(5)	AC17
DDC_DOUT_B5_DPP	AC6					D_BP(5)	AC19
DDC_DOUT_B7_DPN	AA7					D_BN(7)	Y22
DDC_DOUT_B7_DPP	Y7					D_BP(7)	Y20
DDC_DOUT_B9_DPN	W4					D_BN(9)	Y28
DDC_DOUT_B9_DPP	V4					D_BP(9)	AB28
DDC_DOUT_B11_DPN	V7					D_BN(11)	V26
DDC_DOUT_B11_DPP	V6					D_BP(11)	Y26
DDC_DOUT_B13_DPN	T4					D_BN(13)	R29
DDC_DOUT_B13_DPP	T5					D_BP(13)	T28
DDC_DOUT_B15_DPN	U7					D_BN(15)	N27
DDC_DOUT_B15_DPP	T7					D_BP(15)	P26
DDC_SCTRL_AN	R1					SCTRL_AN	C21
DDC_SCTRL_AP	P1					SCTRL_AP	C23
DDC_SCTRL_BN	AA3					SCTRL_BN	AA21
DDC_SCTRL_BP	AB4					SCTRL_BP	AA23

Table 23. DLPC410 Chipset Connections with the DLP7000

DLPC410 (CONTROLLER)		DLPR410 (PROM)		DLPA200 (MICROMIRROR DRIVER)		DLP7000 / UV (DMD)	
PIN		PIN		PIN		PIN	
NAME	NO.	NAME	NO.	NAME	NO.	NAME	NO.
DONE_DDC	K10	\overline{CE}	B4				
INTB_DDC	J11	OE/\overline{RESET}	A3				
PROGB_DDC	J18	\overline{CF}	D1				
PROM_CCK_DDC	J10	CLKOUT	C2				
PROM_D0_DDC	K11	D0	H6				
TCK_JTAG	U11	TCK	H3				
TDO_XCF16DDC	V11	TDO	E6				
TMS_JTAG	V12	TMS	E2				
DAD_A_ADDR0	E1			ADDR0	19		
DAD_A_ADDR1	E2			ADDR1	18		
DAD_A_ADDR2	E3			ADDR2	17		

Table 23. DLPC410 Chipset Connections with the DLP7000 (continued)

DLPC410 (CONTROLLER)		DLPR410 (PROM)		DLPA200 (MICROMIRROR DRIVER)		DLP7000 / UV (DMD)	
PIN		PIN		PIN		PIN	
NAME	NO.	NAME	NO.	NAME	NO.	NAME	NO.
DAD_A_ADDR3	F3			ADDR3	16		
DAD_A_MODE0	C1			MODE0	3		
DAD_A_MODE1	D1			MODE1	2		
DAD_A_SEL0	AB12			SEL0	5		
DAD_A_SEL1	AC12			SEL1	4		
DAD_A_STROBE	AF3			STROBE	15		
DAD_INIT	AF4			$\overline{\text{RESET}}$	59		
$\overline{\text{DAD_OE}}$	AF5			$\overline{\text{OE}}$	6		
$\overline{\text{DAD_A_SCPEN}}$	AE3			$\overline{\text{SCPEN}}$	58		
SCPCLK	AB15			SCPCLK	56	SCPCLK	E3
SCPDI	AA15			SCPDO	57	SCPDO	B2
SCPDO	AA14			SCPDI	42	SCPDI	F4
$\overline{\text{DMD_A_SCPEN}}$	AB14					$\overline{\text{SCPEN}}$	D4
DMD_A_RESET	AD14					$\overline{\text{PWRDN}}$	C3
DDC_DCLKOUT_A_DPN	N1					DCLK_AN	B22
DDC_DCLKOUT_A_DPP	M1					DCLK_AP	B24
DDC_DCLKOUT_B_DPN	Y5					DCLK_BN	AB22
DDC_DCLKOUT_B_DPP	Y6					DCLK_BP	AB24
DDC_DOUT_A0_DPN	AE2					D_AN(0)	B10
DDC_DOUT_A0_DPP	AF2					D_AP(0)	B12
DDC_DOUT_A1_DPN	AD1					D_AN(1)	A13
DDC_DOUT_A1_DPP	AE1					D_AP(1)	A11
DDC_DOUT_A2_DPN	AC1					D_AN(2)	D16
DDC_DOUT_A2_DPP	AC2					D_AP(2)	D14
DDC_DOUT_A3_DPN	AB1					D_AN(3)	C17
DDC_DOUT_A3_DPP	AB2					D_AP(3)	C15
DDC_DOUT_A4_DPN	Y2					D_AN(4)	B18
DDC_DOUT_A4_DPP	AA2					D_AP(4)	B16
DDC_DOUT_A5_DPN	W1					D_AN(5)	A17
DDC_DOUT_A5_DPP	Y1					D_AP(5)	A19
DDC_DOUT_A6_DPN	V1					D_AN(6)	A25
DDC_DOUT_A6_DPP	V2					D_AP(6)	A23
DDC_DOUT_A7_DPN	U1					D_AN(7)	D22
DDC_DOUT_A7_DPP	U2					D_AP(7)	D20
DDC_DOUT_A8_DPN	R2					D_AN(8)	C29
DDC_DOUT_A8_DPP	T2					D_AP(8)	A29
DDC_DOUT_A9_DPN	N2					D_AN(9)	D28
DDC_DOUT_A9_DPP	M2					D_AP(9)	B28
DDC_DOUT_A10_DPN	K1					D_AN(10)	E27
DDC_DOUT_A10_DPP	L2					D_AP(10)	C27
DDC_DOUT_A11_DPN	K2					D_AN(11)	F26
DDC_DOUT_A11_DPP	K3					D_AP(11)	D26
DDC_DOUT_A12_DPN	J3					D_AN(12)	G29
DDC_DOUT_A12_DPP	H3					D_AP(12)	F30
DDC_DOUT_A13_DPN	H2					D_AN(13)	H28

Table 23. DLPC410 Chipset Connections with the DLP7000 (continued)

DLPC410 (CONTROLLER)		DLPR410 (PROM)		DLPA200 (MICROMIRROR DRIVER)		DLP7000 / UV (DMD)	
PIN		PIN		PIN		PIN	
NAME	NO.	NAME	NO.	NAME	NO.	NAME	NO.
DDC_DOUT_A13_DPP	J1					D_AP(13)	H30
DDC_DOUT_A14_DPN	H1					D_AN(14)	J27
DDC_DOUT_A14_DPP	G1					D_AP(14)	J29
DDC_DOUT_A15_DPN	G2					D_AN(15)	K26
DDC_DOUT_A15_DPP	F2					D_AP(15)	K28
DDC_DOUT_B0_DPN	AE5					D_BN(0)	AB10
DDC_DOUT_B0_DPP	AE6					D_BP(0)	AB12
DDC_DOUT_B1_DPN	AD3					D_BN(1)	AC13
DDC_DOUT_B1_DPP	AD4					D_BP(1)	AC11
DDC_DOUT_B2_DPN	AD5					D_BN(2)	Y16
DDC_DOUT_B2_DPP	AD6					D_BP(2)	Y14
DDC_DOUT_B3_DPN	AC3					D_BN(3)	AA17
DDC_DOUT_B3_DPP	AC4					D_BP(3)	AA15
DDC_DOUT_B4_DPN	AB5					D_BN(4)	AB18
DDC_DOUT_B4_DPP	AB6					D_BP(4)	AB16
DDC_DOUT_B5_DPN	AB7					D_BN(5)	AC17
DDC_DOUT_B5_DPP	AC6					D_BP(5)	AC19
DDC_DOUT_B6_DPN	AA5					D_BN(6)	AC25
DDC_DOUT_B6_DPP	AA4					D_BP(6)	AC23
DDC_DOUT_B7_DPN	AA7					D_BN(7)	Y22
DDC_DOUT_B7_DPP	Y7					D_BP(7)	Y20
DDC_DOUT_B8_DPN	Y3					D_BN(8)	AA29
DDC_DOUT_B8_DPP	W3					D_BP(8)	AC29
DDC_DOUT_B9_DPN	W4					D_BN(9)	Y28
DDC_DOUT_B9_DPP	V4					D_BP(9)	AB28
DDC_DOUT_B10_DPN	W6					D_BN(10)	W27
DDC_DOUT_B10_DPP	W5					D_BP(10)	AA27
DDC_DOUT_B11_DPN	V7					D_BN(11)	V26
DDC_DOUT_B11_DPP	V6					D_BP(11)	Y26
DDC_DOUT_B12_DPN	U4					D_BN(12)	T30
DDC_DOUT_B12_DPP	V3					D_BP(12)	U29
DDC_DOUT_B13_DPN	T4					D_BN(13)	R29
DDC_DOUT_B13_DPP	T5					D_BP(13)	T28
DDC_DOUT_B14_DPN	U6					D_BN(14)	R27
DDC_DOUT_B14_DPP	U5					D_BP(14)	P28
DDC_DOUT_B15_DPN	U7					D_BN(15)	N27
DDC_DOUT_B15_DPP	T7					D_BP(15)	P26
DDC_SCTRL_AN	R1					SCTRL_AN	C21
DDC_SCTRL_AP	P1					SCTRL_AP	C23
DDC_SCTRL_BN	AA3					SCTRL_BN	AA21
DDC_SCTRL_BP	AB4					SCTRL_BP	AA23

Table 24. DLPC410 Chipset Connections with the DLP9500

DLPC410 (CONTROLLER)		DLPR410 (PROM)		DLPA200 Number 1 (MICROMIRROR DRIVER)		DLPA200 Number 2 (MICROMIRROR DRIVER)		DLP9500 or UV (DMD)	
PIN		PIN		PIN		PIN		PIN	
NAME	NO.	NAME	NO.	NAME	NO.	NAME	NO.	NAME	NO.
DONE_DDC	K10	\overline{CE}	B4						
INTB_DDC	J11	OE/\overline{RESET}	A3						
PROGB_DDC	J18	\overline{CF}	D1						
PROM_CCK_DDC	J10	CLKOUT	C2						
PROM_D0_DDC	K11	D0	H6						
TCK_JTAG	U11	TCK	H3						
TDO_XCF16DDC	V11	TDO	E6						
TMS_JTAG	V12	TMS	E2						
DAD_A_ADDR0	E1			ADDR0	19				
DAD_A_ADDR1	E2			ADDR1	18				
DAD_A_ADDR2	E3			ADDR2	17				
DAD_A_ADDR3	F3			ADDR3	16				
DAD_A_MODE0	C1			MODE0	3				
DAD_A_MODE1	D1			MODE1	2				
DAD_A_SEL0	AB12			SEL0	5				
DAD_A_SEL1	AC12			SEL1	4				
DAD_A_STROBE	AF3			STROBE	15				
DAD_B_ADDR0	E26					ADDR0	19		
DAD_B_ADDR1	E25					ADDR1	18		
DAD_B_ADDR2	F25					ADDR2	17		
DAD_B_ADDR3	F24					ADDR3	16		
DAD_B_MODE0	D26					MODE0	3		
DAD_B_MODE1	D25					MODE1	2		
DAD_B_SEL0	R22					SEL0	5		
DAD_B_SEL1	R23					SEL1	4		
DAD_B_STROBE	AB20					STROBE	15		
DAD_INIT	AF4			\overline{RESET}	59	\overline{RESET}	59		
$\overline{DAD_OE}$	AF5			\overline{OE}	6	\overline{OE}	6		
$\overline{DAD_A_SCPEN}$	AE3			\overline{SCPEN}	58				
$\overline{DAD_B_SCPEN}$	AB19					\overline{SCPEN}	58		
SCPCLK	AB15			SCPCLK	56	SCPCLK	56	SCPCLK	AE1
SCPDI	AA15			SCPDO	57	SCPDO	57	SCPDO	AC3
SCPDO	AA14			SCPDI	42	SCPDI	42	SCPDI	AD2
$\overline{DMD_A_SCPEN}$	AB14							\overline{SCPEN}	AD4
DMD_A_RESET	AD14							\overline{PWRDN}	B4
DDC_DCLKOUT_A_DPN	N1							DCLK_AN	D10
DDC_DCLKOUT_A_DPP	M1							DCLK_AP	D8
DDC_DCLKOUT_B_DPN	Y5							DCLK_BN	AJ11
DDC_DCLKOUT_B_DPP	Y6							DCLK_BP	AJ9
DDC_DCLKOUT_C_DPN	AA22							DCLK_CN	C23
DDC_DCLKOUT_C_DPP	AB22							DCLK_CP	C21
DDC_DCLKOUT_D_DPN	M26							DCLK_DN	AJ23
DDC_DCLKOUT_D_DPP	M25							DCLK_DP	AJ21
DDC_DOUT_A0_DPN	AE2							D_AN(0)	F2

Table 24. DLPC410 Chipset Connections with the DLP9500 (continued)

DLPC410 (CONTROLLER)		DLPR410 (PROM)		DLPA200 Number 1 (MICROMIRROR DRIVER)		DLPA200 Number 2 (MICROMIRROR DRIVER)		DLP9500 or UV (DMD)	
PIN		PIN		PIN		PIN		PIN	
NAME	NO.	NAME	NO.	NAME	NO.	NAME	NO.	NAME	NO.
DDC_DOUT_A0_DPP	AF2							D_AP(0)	F4
DDC_DOUT_A1_DPN	AD1							D_AN(1)	H8
DDC_DOUT_A1_DPP	AE1							D_AP(1)	H10
DDC_DOUT_A2_DPN	AC1							D_AN(2)	E5
DDC_DOUT_A2_DPP	AC2							D_AP(2)	E3
DDC_DOUT_A3_DPN	AB1							D_AN(3)	G9
DDC_DOUT_A3_DPP	AB2							D_AP(3)	G11
DDC_DOUT_A4_DPN	Y2							D_AN(4)	D2
DDC_DOUT_A4_DPP	AA2							D_AP(4)	D4
DDC_DOUT_A5_DPN	W1							D_AN(5)	G3
DDC_DOUT_A5_DPP	Y1							D_AP(5)	G5
DDC_DOUT_A6_DPN	V1							D_AN(6)	E11
DDC_DOUT_A6_DPP	V2							D_AP(6)	E9
DDC_DOUT_A7_DPN	U1							D_AN(7)	F8
DDC_DOUT_A7_DPP	U2							D_AP(7)	F10
DDC_DOUT_A8_DPN	R2							D_AN(8)	C9
DDC_DOUT_A8_DPP	T2							D_AP(8)	C11
DDC_DOUT_A9_DPN	N2							D_AN(9)	H2
DDC_DOUT_A9_DPP	M2							D_AP(9)	H4
DDC_DOUT_A10_DPN	K1							D_AN(10)	B10
DDC_DOUT_A10_DPP	L2							D_AP(10)	B8
DDC_DOUT_A11_DPN	K2							D_AN(11)	G15
DDC_DOUT_A11_DPP	K3							D_AP(11)	H14
DDC_DOUT_A12_DPN	J3							D_AN(12)	D14
DDC_DOUT_A12_DPP	H3							D_AP(12)	D16
DDC_DOUT_A13_DPN	H2							D_AN(13)	F14
DDC_DOUT_A13_DPP	J1							D_AP(13)	F16
DDC_DOUT_A14_DPN	H1							D_AN(14)	C17
DDC_DOUT_A14_DPP	G1							D_AP(14)	C15
DDC_DOUT_A15_DPN	G2							D_AN(15)	H16
DDC_DOUT_A15_DPP	F2							D_AP(15)	G17
DDC_DOUT_B0_DPN	AE5							D_BN(0)	AH2
DDC_DOUT_B0_DPP	AE6							D_BP(0)	AH4
DDC_DOUT_B1_DPN	AD3							D_BN(1)	AD8
DDC_DOUT_B1_DPP	AD4							D_BP(1)	AD10
DDC_DOUT_B2_DPN	AD5							D_BN(2)	AJ5
DDC_DOUT_B2_DPP	AD6							D_BP(2)	AJ3
DDC_DOUT_B3_DPN	AC3							D_BN(3)	AE3
DDC_DOUT_B3_DPP	AC4							D_BP(3)	AE5
DDC_DOUT_B4_DPN	AB5							D_BN(4)	AG9
DDC_DOUT_B4_DPP	AB6							D_BP(4)	AG11
DDC_DOUT_B5_DPN	AB7							D_BN(5)	AE11
DDC_DOUT_B5_DPP	AC6							D_BP(5)	AE9
DDC_DOUT_B6_DPN	AA5							D_BN(6)	AH10

Table 24. DLPC410 Chipset Connections with the DLP9500 (continued)

DLPC410 (CONTROLLER)		DLPR410 (PROM)		DLPA200 Number 1 (MICROMIRROR DRIVER)		DLPA200 Number 2 (MICROMIRROR DRIVER)		DLP9500 or UV (DMD)	
PIN		PIN		PIN		PIN		PIN	
NAME	NO.	NAME	NO.	NAME	NO.	NAME	NO.	NAME	NO.
DDC_DOUT_B6_DPP	AA4							D_BP(6)	AH8
DDC_DOUT_B7_DPN	AA7							D_BN(7)	AF10
DDC_DOUT_B7_DPP	Y7							D_BP(7)	AF8
DDC_DOUT_B8_DPN	Y3							D_BN(8)	AK8
DDC_DOUT_B8_DPP	W3							D_BP(8)	AK10
DDC_DOUT_B9_DPN	W4							D_BN(9)	AG5
DDC_DOUT_B9_DPP	V4							D_BP(9)	AG3
DDC_DOUT_B10_DPN	W6							D_BN(10)	AL11
DDC_DOUT_B10_DPP	W5							D_BP(10)	AL9
DDC_DOUT_B11_DPN	V7							D_BN(11)	AE15
DDC_DOUT_B11_DPP	V6							D_BP(11)	AD14
DDC_DOUT_B12_DPN	U4							D_BN(12)	AH14
DDC_DOUT_B12_DPP	V3							D_BP(12)	AH16
DDC_DOUT_B13_DPN	T4							D_BN(13)	AF14
DDC_DOUT_B13_DPP	T5							D_BP(13)	AF16
DDC_DOUT_B14_DPN	U6							D_BN(14)	AJ17
DDC_DOUT_B14_DPP	U5							D_BP(14)	AJ15
DDC_DOUT_B15_DPN	U7							D_BN(15)	AD16
DDC_DOUT_B15_DPP	T7							D_BP(15)	AE17
DDC_DOUT_C0_DPN	T22							D_CN(0)	B14
DDC_DOUT_C0_DPP	T23							D_CP(0)	B16
DDC_DOUT_C1_DPN	R20							D_CN(1)	E15
DDC_DOUT_C1_DPP	R21							D_CP(1)	E17
DDC_DOUT_C2_DPN	T19							D_CN(2)	A17
DDC_DOUT_C2_DPP	T20							D_CP(2)	A15
DDC_DOUT_C3_DPN	U21							D_CN(3)	G21
DDC_DOUT_C3_DPP	U22							D_CP(3)	H20
DDC_DOUT_C4_DPN	U20							D_CN(4)	B20
DDC_DOUT_C4_DPP	U19							D_CP(4)	B22
DDC_DOUT_C5_DPN	V23							D_CN(5)	F20
DDC_DOUT_C5_DPP	V24							D_CP(5)	F22
DDC_DOUT_C6_DPN	V22							D_CN(6)	D22
DDC_DOUT_C6_DPP	V21							D_CP(6)	D20
DDC_DOUT_C7_DPN	W19							D_CN(7)	G23
DDC_DOUT_C7_DPP	V19							D_CP(7)	H22
DDC_DOUT_C8_DPN	W23							D_CN(8)	B26
DDC_DOUT_C8_DPP	W24							D_CP(8)	B28
DDC_DOUT_C9_DPN	Y22							D_CN(9)	F28
DDC_DOUT_C9_DPP	Y23							D_CP(9)	F26
DDC_DOUT_C10_DPN	Y20							D_CN(10)	C29
DDC_DOUT_C10_DPP	Y21							D_CP(10)	C27
DDC_DOUT_C11_DPN	AA24							D_CN(11)	G27
DDC_DOUT_C11_DPP	AA23							D_CP(11)	G29
DDC_DOUT_C12_DPN	AA19							D_CN(12)	D26

Table 24. DLPC410 Chipset Connections with the DLP9500 (continued)

DLPC410 (CONTROLLER)		DLPR410 (PROM)		DLPA200 Number 1 (MICROMIRROR DRIVER)		DLPA200 Number 2 (MICROMIRROR DRIVER)		DLP9500 or UV (DMD)	
PIN		PIN		PIN		PIN		PIN	
NAME	NO.	NAME	NO.	NAME	NO.	NAME	NO.	NAME	NO.
DDC_DOUT_C12_DPP	AA20							D_CP(12)	D28
DDC_DOUT_C13_DPN	AC24							D_CN(13)	H28
DDC_DOUT_C13_DPP	AB24							D_CP(13)	H26
DDC_DOUT_C14_DPN	AC19							D_CN(14)	E29
DDC_DOUT_C14_DPP	AD19							D_CP(14)	E27
DDC_DOUT_C15_DPN	AC22							D_CN(15)	J29
DDC_DOUT_C15_DPP	AC23							D_CP(15)	J27
DDC_DOUT_D0_DPN	AB26							D_DN(0)	AK14
DDC_DOUT_D0_DPP	AC26							D_DP(0)	AK16
DDC_DOUT_D1_DPN	AA25							D_DN(1)	AG15
DDC_DOUT_D1_DPP	AB25							D_DP(1)	AG17
DDC_DOUT_D2_DPN	Y26							D_DN(2)	AL17
DDC_DOUT_D2_DPP	Y25							D_DP(2)	AL15
DDC_DOUT_D3_DPN	W26							D_DN(3)	AE21
DDC_DOUT_D3_DPP	W25							D_DP(3)	AD20
DDC_DOUT_D4_DPN	U26							D_DN(4)	AK20
DDC_DOUT_D4_DPP	V26							D_DP(4)	AK22
DDC_DOUT_D5_DPN	U25							D_DN(5)	AF20
DDC_DOUT_D5_DPP	U24							D_DP(5)	AF22
DDC_DOUT_D6_DPN	T25							D_DN(6)	AH22
DDC_DOUT_D6_DPP	T24							D_DP(6)	AH20
DDC_DOUT_D7_DPN	R26							D_DN(7)	AE23
DDC_DOUT_D7_DPP	R25							D_DP(7)	AD22
DDC_DOUT_D8_DPN	P24							D_DN(8)	AK26
DDC_DOUT_D8_DPP	P25							D_DP(8)	AK28
DDC_DOUT_D9_DPN	N24							D_DN(9)	AF28
DDC_DOUT_D9_DPP	M24							D_DP(9)	AF26
DDC_DOUT_D10_DPN	L25							D_DN(10)	AJ29
DDC_DOUT_D10_DPP	L24							D_DP(10)	AJ27
DDC_DOUT_D11_DPN	K26							D_DN(11)	AE27
DDC_DOUT_D11_DPP	K25							D_DP(11)	AE29
DDC_DOUT_D12_DPN	J26							D_DN(12)	AH26
DDC_DOUT_D12_DPP	J25							D_DP(12)	AH28
DDC_DOUT_D13_DPN	J24							D_DN(13)	AD28
DDC_DOUT_D13_DPP	H24							D_DP(13)	AD26
DDC_DOUT_D14_DPN	H26							D_DN(14)	AG29
DDC_DOUT_D14_DPP	G26							D_DP(14)	AG27
DDC_DOUT_D15_DPN	G25							D_DN(15)	AC29
DDC_DOUT_D15_DPP	G24							D_DP(15)	AC27
DDC_SCTRL_AN	R1							SCTRL_AN	J3
DDC_SCTRL_AP	P1							SCTRL_AP	J5
DDC_SCTRL_BN	AA3							SCTRL_BN	AF4
DDC_SCTRL_BP	AB4							SCTRL_BP	AF2
DDC_SCTRL_CN	W20							SCTRL_CN	E23

Table 24. DLPC410 Chipset Connections with the DLP9500 (continued)

DLPC410 (CONTROLLER)		DLPR410 (PROM)		DLPA200 Number 1 (MICROMIRROR DRIVER)		DLPA200 Number 2 (MICROMIRROR DRIVER)		DLP9500 or UV (DMD)	
PIN		PIN		PIN		PIN		PIN	
NAME	NO.	NAME	NO.	NAME	NO.	NAME	NO.	NAME	NO.
DDC_SCTRL_CP	W21							SCTRL_CP	E21
DDC_SCTRL_DN	N26							SCTRL_DN	AG23
DDC_SCTRL_DP	P26							SCTRL_DP	AG21

12 Device and Documentation Support

12.1 Device Support

12.1.1 Device Marking

Figure 26 is representative of the Xilinx XC5VLX30 FPGA configured for the DLPC410 device.

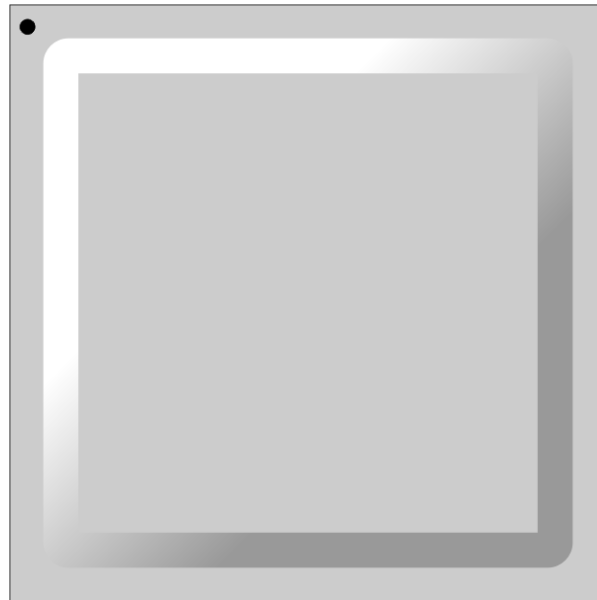

Figure 26. Diagram of the Xilinx XC5VLX30 FPGA

Figure 27 provides a legend for reading the Xilinx device marking for this DLP device.

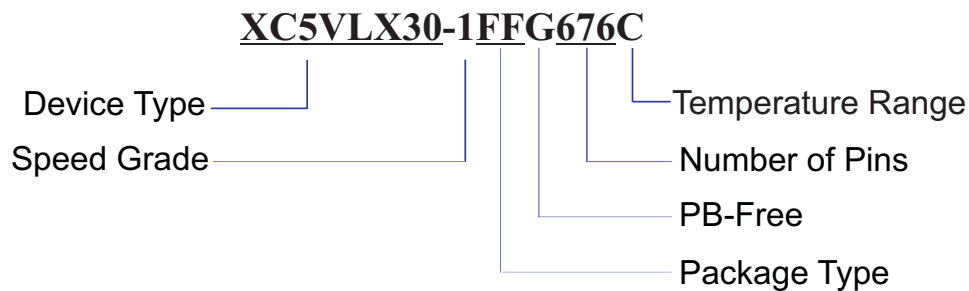

Figure 27. Legend

12.1.2 Device Nomenclature

Figure 28 provides a legend of reading the complete device name for any DLP device.

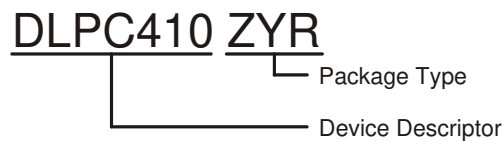

Figure 28. Device Nomenclature

12.2 Documentation Support

12.2.1 Related Documentation

Table 25. Related Documentation

DOCUMENT	TI LITERATURE NUMBER
DLP650LNIR 0.65 NIR WXGA S450 DMD data sheet	DLPS136
DLP7000 DLP 0.7 XGA 2x LVDS Type A DMD data sheet	DLPS026
DLP7000UV DLP 0.7 UV XGA 2x LVDS Type A DMD data sheet	DLPS061
DLP9500 DLP 0.95 1080p 2x LVDS Type A DMD data sheet	DLPS025
DLP9500UV DLP 0.95 UV 1080p 2x LVDS Type A DMD data sheet	DLPS033
DLPA200 DMD Micromirror Driver data sheet	DLPS015
DLPR410 Configuration PROM data sheet	DLPS027

12.3 Support Resources

[TI E2E™ support forums](#) are an engineer's go-to source for fast, verified answers and design help — straight from the experts. Search existing answers or ask your own question to get the quick design help you need.

Linked content is provided "AS IS" by the respective contributors. They do not constitute TI specifications and do not necessarily reflect TI's views; see TI's [Terms of Use](#).

12.4 Trademarks

E2E is a trademark of Texas Instruments.

DLP is a registered trademark of Texas Instruments.

12.5 Electrostatic Discharge Caution



These devices have limited built-in ESD protection. The leads should be shorted together or the device placed in conductive foam during storage or handling to prevent electrostatic damage to the MOS gates.

12.6 Glossary

[SLYZ022](#) — *TI Glossary*.

This glossary lists and explains terms, acronyms, and definitions.

13 Mechanical, Packaging, and Orderable Information

The following pages include mechanical, packaging, and orderable information. This information is the most current data available for the designated devices. This data is subject to change without notice and revision of this document. For browser-based versions of this data sheet, refer to the left-hand navigation.

PACKAGING INFORMATION

Orderable Device	Status (1)	Package Type	Package Drawing	Pins	Package Qty	Eco Plan (2)	Lead finish/ Ball material (6)	MSL Peak Temp (3)	Op Temp (°C)	Device Marking (4/5)	Samples
DLPC410ZYR	ACTIVE			676	1	TBD	Call TI	Call TI	0 to 85		Samples

(1) The marketing status values are defined as follows:

ACTIVE: Product device recommended for new designs.

LIFEBUY: TI has announced that the device will be discontinued, and a lifetime-buy period is in effect.

NRND: Not recommended for new designs. Device is in production to support existing customers, but TI does not recommend using this part in a new design.

PREVIEW: Device has been announced but is not in production. Samples may or may not be available.

OBSOLETE: TI has discontinued the production of the device.

(2) **RoHS:** TI defines "RoHS" to mean semiconductor products that are compliant with the current EU RoHS requirements for all 10 RoHS substances, including the requirement that RoHS substance do not exceed 0.1% by weight in homogeneous materials. Where designed to be soldered at high temperatures, "RoHS" products are suitable for use in specified lead-free processes. TI may reference these types of products as "Pb-Free".

RoHS Exempt: TI defines "RoHS Exempt" to mean products that contain lead but are compliant with EU RoHS pursuant to a specific EU RoHS exemption.

Green: TI defines "Green" to mean the content of Chlorine (Cl) and Bromine (Br) based flame retardants meet JS709B low halogen requirements of <=1000ppm threshold. Antimony trioxide based flame retardants must also meet the <=1000ppm threshold requirement.

(3) MSL, Peak Temp. - The Moisture Sensitivity Level rating according to the JEDEC industry standard classifications, and peak solder temperature.

(4) There may be additional marking, which relates to the logo, the lot trace code information, or the environmental category on the device.

(5) Multiple Device Markings will be inside parentheses. Only one Device Marking contained in parentheses and separated by a "-" will appear on a device. If a line is indented then it is a continuation of the previous line and the two combined represent the entire Device Marking for that device.

(6) Lead finish/Ball material - Orderable Devices may have multiple material finish options. Finish options are separated by a vertical ruled line. Lead finish/Ball material values may wrap to two lines if the finish value exceeds the maximum column width.

Important Information and Disclaimer:The information provided on this page represents TI's knowledge and belief as of the date that it is provided. TI bases its knowledge and belief on information provided by third parties, and makes no representation or warranty as to the accuracy of such information. Efforts are underway to better integrate information from third parties. TI has taken and continues to take reasonable steps to provide representative and accurate information but may not have conducted destructive testing or chemical analysis on incoming materials and chemicals. TI and TI suppliers consider certain information to be proprietary, and thus CAS numbers and other limited information may not be available for release.

In no event shall TI's liability arising out of such information exceed the total purchase price of the TI part(s) at issue in this document sold by TI to Customer on an annual basis.

IMPORTANT NOTICE AND DISCLAIMER

TI PROVIDES TECHNICAL AND RELIABILITY DATA (INCLUDING DATASHEETS), DESIGN RESOURCES (INCLUDING REFERENCE DESIGNS), APPLICATION OR OTHER DESIGN ADVICE, WEB TOOLS, SAFETY INFORMATION, AND OTHER RESOURCES "AS IS" AND WITH ALL FAULTS, AND DISCLAIMS ALL WARRANTIES, EXPRESS AND IMPLIED, INCLUDING WITHOUT LIMITATION ANY IMPLIED WARRANTIES OF MERCHANTABILITY, FITNESS FOR A PARTICULAR PURPOSE OR NON-INFRINGEMENT OF THIRD PARTY INTELLECTUAL PROPERTY RIGHTS.

These resources are intended for skilled developers designing with TI products. You are solely responsible for (1) selecting the appropriate TI products for your application, (2) designing, validating and testing your application, and (3) ensuring your application meets applicable standards, and any other safety, security, or other requirements. These resources are subject to change without notice. TI grants you permission to use these resources only for development of an application that uses the TI products described in the resource. Other reproduction and display of these resources is prohibited. No license is granted to any other TI intellectual property right or to any third party intellectual property right. TI disclaims responsibility for, and you will fully indemnify TI and its representatives against, any claims, damages, costs, losses, and liabilities arising out of your use of these resources.

TI's products are provided subject to TI's Terms of Sale (<https://www.ti.com/legal/termsofsale.html>) or other applicable terms available either on [ti.com](https://www.ti.com) or provided in conjunction with such TI products. TI's provision of these resources does not expand or otherwise alter TI's applicable warranties or warranty disclaimers for TI products.

Mailing Address: Texas Instruments, Post Office Box 655303, Dallas, Texas 75265
Copyright © 2021, Texas Instruments Incorporated