

PART NUMBER	REVISION	DESCRIPTION	FEED TYPE
2836040-1	C	FINE CRIMP HEIGHT ADJUST	MECHANICAL
2836040-2	C	FINE CRIMP HEIGHT ADJUST	PNEUMATIC
7-2836040-1	C	MECHANICAL AND CRIMP TOOLING KIT	MECHANICAL
7-2836040-2	C	PNEUMATIC AND CRIMP TOOLING KIT	PNEUMATIC
7-2836040-7	A	CRIMP TOOLING KIT	-

ATLANTIC VERSION TERMINATOR INTERFACE ADAPTER

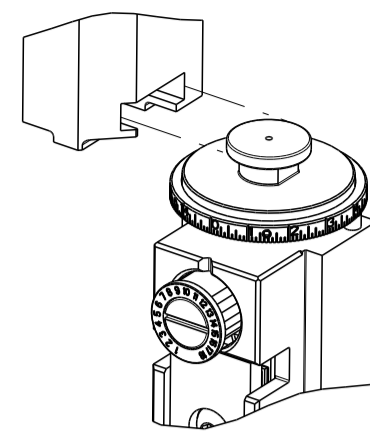

APPLICATOR DATA		
CRIMP	SIZE	TYPE
WIRE	0.79 mm [.031]	F
INSUL	1.02 mm [.040]	F

APPLICATOR INSTRUCTIONS  
408-35042

TERMINAL DATA: SAMTEC TERMINAL SAMTEC CRIMP SPECIFICATION			
TERMINAL NAME: ACCLIMATE DISCRETE WIRE CONTACT			
WIRE STRIP LENGTH	INSULATION DIAMETER RANGE		
1.46-2.23 mm [.058-.088 IN]	Ø0.74-0.94 mm [.029-.037 IN]		
TERMINAL APPLICATION SPECIFICATION	CC-393-XXXX-X-X Rev B		
TERMINALS APPLIED			
TE TERMINAL	SAMTEC TERMINAL	TE TERMINAL	SAMTEC TERMINAL
2113901-1	CC393-2830-L-X		

WIRE SIZE	CRIMP HEIGHT mm [INCH]	CRIMP HEIGHT REFERENCE SETTING
28 AWG	0.46 +/- 0.05 [.018 +/- .002]	8.1
30 AWG	0.41 +/- 0.05 [.016 +/- .002]	8.4

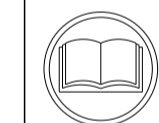

- RECOMMENDED SPARE PARTS
- REFER TO SUPPLIED INSTRUCTION SHEET FOR CLEANING, LUBRICATION AND STORAGE OF APPLICATOR.
- APPLY PART NUMBER 2-23419-6 LOCTITE TO THREADS OF ITEM 242.
- CRIMP HEIGHT REFERENCE SETTING WAS THE SETTING USED WHEN THE APPLICATOR WAS QUALIFIED AT THE FACTORY. ADJUSTMENT MAY BE NECESSARY WHEN RUNNING APPLICATOR IN THE FIELD.
- TERMINAL LUBRICANT IS RECOMMENDED.
- UNLESS SPECIFIED OTHERWISE TORQUE VALUES SHALL BE USED PER DOCUMENT, 101-35000.

**\*WARNING**  
ON INSTALLATION, SET WIRE DISC TO CRIMP HEIGHT REFERENCE SETTING FOR LARGEST WIRE SIZE. CRIMP HEIGHT REFERENCE SETTINGS GREATER THAN THE VALUE SHOWN MAY CAUSE DAMAGE TO THE CRIMP TOOLING. REFER TO THE INSTRUCTION SHEET FOR PROPER SETUP AND ADJUSTMENTS.

ATLANTIC VERSION  
Shown on sheets 1 of 4 & 2 of 4  
(Pacific version shown on sheets 3 of 4 & 4 of 4)

LOC	DIST	REVISIONS					
		P	LTN	DESCRIPTION	DATE	DWN	APVD
A	66			RELEASED	08DEC2015	BW	GB
				ECR-17-009399	28JUN2017	KH	TE
				ECR-19-006994	02MAY2019	TB	CT

-	1	-	1	-	2119640-1	PUSH ROD, AIR FEED	250	
-	1	-	1	-	1803259-1	BUSHING, FLANGED	249	
-	1	-	1	-	2119641-1	FEED CAM, AIR FEED	248	
-	1	1	1	1	2119082-5	CAM, SNAIL, INSULATION ADJUSTMENT	244	
-	1	1	1	1	2079764-1	WASHER, WAVE SPRING, CREST-TO-CREST	243	
-	1	1	1	1	2119083-1	RETAINER, INSULATION DIAL	242	
-	1	1	1	1	7-18023-7	SCR, SKT HD CAP M3 X 4.0	241	
-	-	1	-	1	2119580-1	MECHANICAL FEED ASSEMBLY	239	
-	1	-	1	-	2063440-1	AIR FEED MODULE	238	
-	2	-	2	-	21045-3	RING, RETAIN, EXTERN, 3/16 CRESCENT	172	
-	REF	REF	REF	REF	994970-2	COUNTER, MAGNETIC	164	
-	1	-	1	-	240638-1	SPRING, FEED FINGER	163	
-	1	-	1	-	3-23627-7	PIN, RETAIN, GRVD, 3/16 X .854	137	
-	1	-	1	-	2119799-1	HOLDER, FEED FINGER, AF	136	
-	1	1	1	1	2119955-1	ASSY, LUBRICATOR, SIDE FEED	113	
-	1	1	1	1	2844908-1	SCREW, LOCKING	99	
-	1	1	1	1	2844907-1	POST, LOCKING	98	
-	1	1	1	1	2-455888-3	SPACER, CRIMPER	82	
-	1	1	1	1	1803607-1	DOCUMENTATION PACKAGE	71	
-	1	1	1	1	2119791-9	DEPRESSOR, WIRE	70	
-	1	1	1	1	2119740-1	TAG, IDENTIFICATION	67	
-	2	2	2	2	2168078-1	SCREW, DRIVE, RH, RoHS, 2 x .188	66	
-	1	1	1	1	2168083-2	SCR, SKT HD CAP, RoHS, M4 X 8.0	60	
-	1	1	1	1	5-18022-5	SCR, HEX HD CAP, M4 X 6.0	59	
-	1	1	1	1	1338685-1	PAWL, FEED	56	
-	4	4	4	4	2168083-3	SCR, SKT HD CAP, RoHS, M4 X 12.0	54	
-	2	2	2	2	1-2168083-0	SCR, SKT HD CAP, RoHS, M4 X 10	53	
-	1	1	1	1	1803382-1	HOLD DOWN, SPRING LOADED	50	
-	1	2	1	2	18023-9	SCR, SKT HD CAP M4 X 6.0	49	
-	-	1	-	1	2119652-1	FEED CAM, PRE FEED	48	
-	-	1	-	1	2119653-1	FEED CAM, POST FEED	47	
-	1	1	1	1	1803583-9	APPLICATOR BASIC ASSEMBLY, SF	46	
-	1	1	1	1	1803515-1	RAM ASSEMBLY, SF ATLANTIC	44	
-	1	1	1	1	1803602-1	SCR, BHSC, RoHS (M8 X 25)	41	
-	1	1	1	1	1752356-3	SUPPORT, TERMINAL	34	
-	2	2	2	2	2079383-5	SCR, BHSC, RoHS (M4 X 20)	33	
-	2	2	2	2	2-2844962-3	SPACER, CYLINDRICAL, STRIP GUIDE	30	
-	1	1	1	1	2844992-1	ASSEMBLY, STRIP GUIDE	29	
-	1	1	1	1	1320928-2	STRIP GUIDE	24	
-	1	1	1	1	2168083-2	SCR, SKT HD CAP, RoHS, M4 X 8.0	21	
-	2	2	2	2	1-18028-2	WASHER, FLAT, REG M4	20	
-	1	1	1	1	2119533-1	STRIPPER, SIDE FEED	19	
-	1	1	1	1	2119806-1	INSERT, SHEAR	13	
-	1	1	1	1	3-22280-3	SPRING, COMPRESSION	12	
-	1	1	1	1	1-356885-4	STOP, SHEAR	11	
-	1	1	1	1	2119805-1	SHEAR HOLDER, FRONT	10	
-	1	1	1	1	1803095-3	FLOATING SHEAR, FRONT	9	
-	1	2	2	1	1	6-1803057-4	ANVIL, COMBINATION	8
-	-	-	-	-	-	-	7	
-	-	-	-	-	-	-	6	
-	1	1	1	1	1-2119757-8	DEPRESSOR, SHEAR	5	
-	1	1	1	1	4-238011-8	BLOCK, CRIMPER SPACER	4	
-	1	2	2	1	1	7-1803017-3	CRIMPER, INSULATION F	3
-	1	1	1	1	455888-5	SPACER, CRIMPER	2	
-	1	2	2	1	1	1803224-6	CRIMPER, WIRE	1
-	77	72	71	-2	-1	PART NO	ITEM NO	

DIMENSIONS:		TOLERANCES UNLESS OTHERWISE SPECIFIED:		MATERIAL:		FINISH:	
mm	0 PLC ±	1 PLC ±	2 PLC ±	3 PLC ±	4 PLC ±	ANGLES ±	FINISH ±
MATERIAL:				FINISH:			

OWN	D. WEAVER	12OCT2015	CHK	G. BAILEY	12OCT2015	APVD	G. BAILEY	12OCT2015
NAME			PRODUCT SPEC			APPLICATION SPEC		
SIZE			CAGE CODE			DRAWING NO		
A1			00779			C=2836040		
Customer Accessible Production Drawing			SCALE			SHEET 1 OF 4		
			1:2			REV C		



PART NUMBER	REVISION	DESCRIPTION	FEED TYPE
2-2836040-1	C	FINE CRIMP HEIGHT ADJUST	MECHANICAL
2-2836040-2	C	FINE CRIMP HEIGHT ADJUST	PNEUMATIC
7-2836040-7	A	CRIMP TOOLING KIT	-

PACIFIC VERSION TERMINATOR  
 INTERFACE ADAPTER

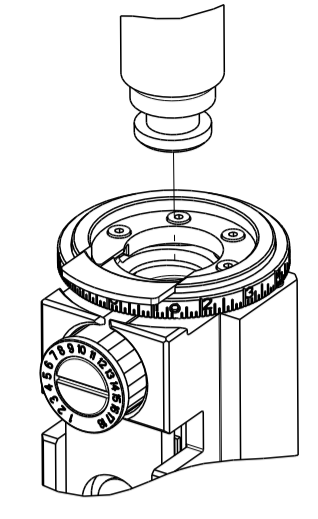

APPLICATOR DATA		
CRIMP	SIZE	TYPE
WIRE	0.79 mm [.031]	F
INSUL	1.02 mm [.040]	F

APPLICATOR INSTRUCTIONS 408-35042

TERMINAL DATA: SAMTEC TERMINAL SAMTEC CRIMP SPECIFICATION  
 TERMINAL NAME: ACCLIMATE DISCRETE WIRE CONTACT

WIRE STRIP LENGTH 1.46-2.23 mm [.058-.088 IN]	INSULATION DIAMETER RANGE Ø0.74-0.94 mm [.029-.037 IN]
--	---

TERMINAL APPLICATION SPECIFICATION CC-393-XXXX-X-X Rev B

TE TERMINAL	SAMTEC TERMINAL	TE TERMINAL	SAMTEC TERMINAL
2113901-1	CC393-2830-L-X		

WIRE SIZE	CRIMP HEIGHT mm [INCH]	CRIMP HEIGHT REFERENCE SETTING
28 AWG	0.46+/-0.05 [.018+/-0.002]	8.1
30 AWG	0.41+/-0.05 [.016+/-0.002]	8.4

- RECOMMENDED SPARE PARTS
  - REFER TO SUPPLIED INSTRUCTION SHEET FOR CLEANING, LUBRICATION AND STORAGE OF APPLICATOR.
  - APPLY PART NUMBER 2-23419-6 LOCTITE TO THREADS OF ITEM 242.
  - CRIMP HEIGHT REFERENCE SETTING WAS THE SETTING USED WHEN THE APPLICATOR WAS QUALIFIED AT THE FACTORY. ADJUSTMENT MAY BE NECESSARY WHEN RUNNING APPLICATOR IN THE FIELD.
  - TERMINAL LUBRICANT IS RECOMMENDED.
6. UNLESS SPECIFIED OTHERWISE TORQUE VALUES SHALL BE USED PER DOCUMENT, 101-35000.

**\*WARNING**  
 ON INSTALLATION, SET WIRE DISC TO CRIMP HEIGHT REFERENCE SETTING FOR LARGEST WIRE SIZE. CRIMP HEIGHT REFERENCE SETTINGS GREATER THAN THE VALUE SHOWN MAY CAUSE DAMAGE TO THE CRIMP TOOLING. REFER TO THE INSTRUCTION SHEET FOR PROPER SETUP AND ADJUSTMENTS.

LOC	DIST	REV	DATE	BY	APPD
A	66	-	-	-	-

REV	DATE	BY	APPD	DESCRIPTION	ITEM NO
-	1	-	-	2119640-1 PUSH ROD, AIR FEED	250
-	1	-	-	1803259-1 BUSHING, FLANGED	249
-	1	1	-	2119082-5 CAM, SNAIL, INSULATION ADJUSTMENT	244
-	1	1	-	2079764-1 WASHER, WAVE SPRING, CREST-TO-CREST	243
-	1	1	-	2119083-1 RETAINER, INSULATION DIAL	242
-	1	1	-	7-18023-7 SCR, SKT HD CAP M3 X 4.0	241
-	-	1	-	2119580-1 MECHANICAL FEED ASSEMBLY	239
-	1	-	-	2063440-1 AIR FEED MODULE	238
-	2	-	-	21045-3 RING, RETAIN, EXTERN, 3/16 CRESCENT	172
-	REF	REF	-	994970-2 COUNTER, MAGNETIC	164
-	1	-	-	240638-1 SPRING, FEED FINGER	163
-	1	-	-	2119641-2 FEED CAM, AIR FEED	151
-	1	1	-	2168083-8 SCR, SKT HD CAP, RoHS, M4 X 16	144
-	4	4	-	2168083-9 SCR, SKT HD CAP, RoHS, M4 X 20	143
-	-	1	-	2119653-2 FEED CAM, POST FEED	142
-	1	1	-	1-1803583-0 APPLICATOR BASIC ASSEMBLY, SF	141
-	1	1	-	1803516-1 RAM ASSEMBLY, SF PACIFIC	140
-	1	-	-	3-23627-7 PIN, RETAIN, GRVD, 3/16 X .854	137
-	1	-	-	2119799-1 HOLDER, FEED FINGER, AF	136
-	1	1	-	2119955-1 ASSY, LUBRICATOR, SIDE FEED	113
-	1	1	-	2844908-1 SCREW, LOCKING	99
-	1	1	-	2844907-1 POST, LOCKING	98
-	1	1	-	2-455888-3 SPACER, CRIMPER	82
-	1	1	-	1803607-1 DOCUMENTATION PACKAGE	71
-	1	1	-	2119791-9 DEPRESSOR, WIRE	70
-	1	1	-	2119740-1 TAG, IDENTIFICATION	67
-	2	2	-	2168078-1 SCREW, DRIVE, RH, RoHS, 2 x .188	66
-	1	1	-	5-18022-5 SCR, HEX HD CAP, M4 X 6.0	59
-	1	1	-	1338685-1 PAWL, FEED	56
-	2	2	-	1-2168083-0 SCR, SKT HD CAP, RoHS, M4 X 10	53
-	1	1	-	1803382-1 HOLD DOWN, SPRING LOADED	50
-	1	2	-	18023-9 SCR, SKT HD CAP M4 X 6.0	49
-	-	1	-	2119652-1 FEED CAM, PRE FEED	48
-	1	1	-	1803602-1 SCR, BHSC, RoHS (M8 X 25)	41
-	1	1	-	1752356-3 SUPPORT, TERMINAL	34
-	2	2	-	2079383-5 SCR, BHSC, RoHS (M4 X 20)	33
-	2	2	-	2-2844962-3 SPACER, CYLINDRICAL, STRIP GUIDE	30
-	1	1	-	2844992-1 ASSEMBLY, STRIP GUIDE	29
-	1	1	-	1320928-2 STRIP GUIDE	24
-	1	1	-	2168083-2 SCR, SKT HD CAP, RoHS, M4 X 8.0	21
-	2	2	-	1-18028-2 WASHER, FLAT, REG M4	20
-	1	1	-	2119533-1 STRIPPER, SIDE FEED	19
-	1	1	-	2119806-1 INSERT, SHEAR	13
-	1	1	-	3-22280-3 SPRING, COMPRESSION	12
-	1	1	-	1-356885-4 STOP, SHEAR	11
-	1	1	-	2119805-1 SHEAR HOLDER, FRONT	10
-	1	1	-	1803095-3 FLOATING SHEAR, FRONT	9
-	1	1	1	6-1803057-4 ANVIL, COMBINATION	8
-	-	-	-	-	7
-	-	-	-	-	6
-	1	1	-	1-2119757-8 DEPRESSOR, SHEAR	5
-	1	1	-	4-238011-8 BLOCK, CRIMPER SPACER	4
-	1	1	1	7-1803017-3 CRIMPER, INSULATION F	3
-	1	1	-	455888-5 SPACER, CRIMPER	2
-	1	1	1	1803224-6 CRIMPER, WIRE	1

PACIFIC VERSION  
 Shown on sheets 3 of 4 & 4 of 4  
 (Atlantic version shown on sheets 1 of 4 & 2 of 4)

DIMENSIONS: mm		TOLERANCES UNLESS OTHERWISE SPECIFIED:		DWG: B. WEAVER 12OCT2015		CHK: G. BAILEY 12OCT2015		APVD: G. BAILEY 12OCT2015		NAME: Ocean Side Feed Applicator	
0 PLC ±		1 PLC ±		2 PLC ±		3 PLC ±		4 PLC ±		SIZE: A1	
ANGLES		FINISH		WEIGHT		SCALE: 1:2		SHEET: 3 OF 4		REV: C	

Customer Accessible Production Drawing

LOC	DIST	REV	DATE	BY	APPV
A	66				
		1			
		2			
		3			
		4			
		5			
		6			
		7			
		8			
		9			
		10			
		11			
		12			
		13			
		14			
		15			
		16			
		17			
		18			
		19			
		20			
		21			
		22			
		23			
		24			
		25			
		26			
		27			
		28			
		29			
		30			
		31			
		32			
		33			
		34			
		35			
		36			
		37			
		38			
		39			
		40			
		41			
		42			
		43			
		44			
		45			
		46			
		47			
		48			
		49			
		50			
		51			
		52			
		53			
		54			
		55			
		56			
		57			
		58			
		59			
		60			
		61			
		62			
		63			
		64			
		65			
		66			
		67			
		68			
		69			
		70			
		71			
		72			
		73			
		74			
		75			
		76			
		77			
		78			
		79			
		80			
		81			
		82			
		83			
		84			
		85			
		86			
		87			
		88			
		89			
		90			
		91			
		92			
		93			
		94			
		95			
		96			
		97			
		98			
		99			
		100			
		101			
		102			
		103			
		104			
		105			
		106			
		107			
		108			
		109			
		110			
		111			
		112			
		113			
		114			
		115			
		116			
		117			
		118			
		119			
		120			
		121			
		122			
		123			
		124			
		125			
		126			
		127			
		128			
		129			
		130			
		131			
		132			
		133			
		134			
		135			
		136			
		137			
		138			
		139			
		140			
		141			
		142			
		143			
		144			
		145			
		146			
		147			
		148			
		149			
		150			
		151			
		152			
		153			
		154			
		155			
		156			
		157			
		158			
		159			
		160			
		161			
		162			
		163			
		164			
		165			
		166			
		167			
		168			
		169			
		170			
		171			
		172			
		173			
		174			
		175			
		176			
		177			
		178			
		179			
		180			
		181			
		182			
		183			
		184			
		185			
		186			
		187			
		188			
		189			
		190			
		191			
		192			
		193			
		194			
		195			
		196			
		197			
		198			
		199			
		200			

# FEED TYPE MECHANICAL

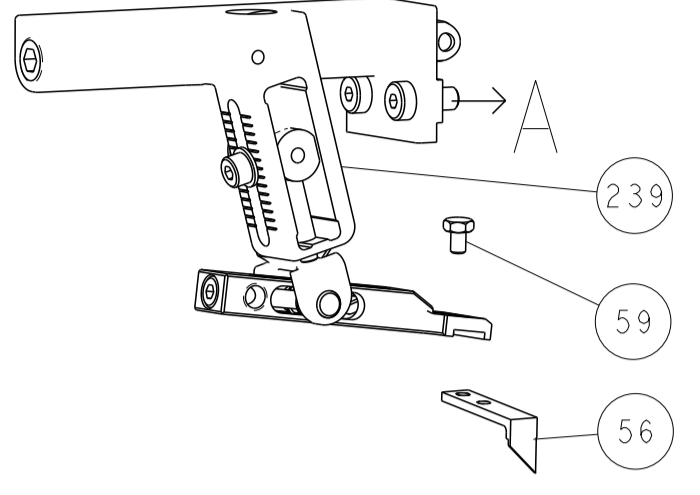

# PNEUMATIC

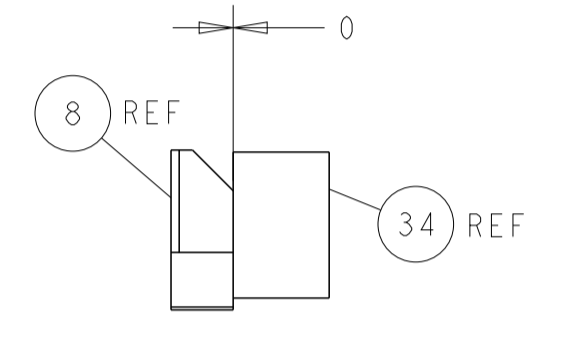
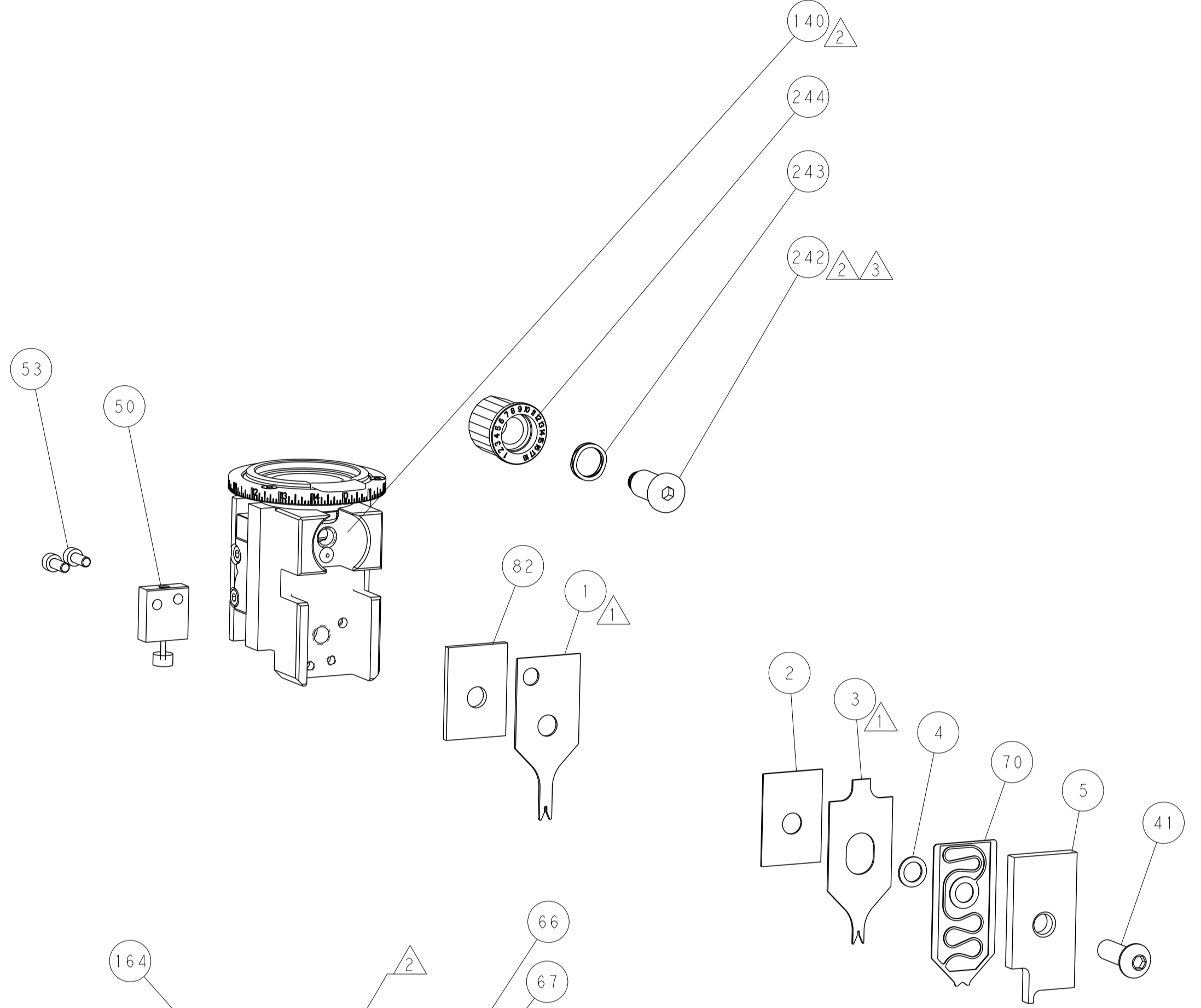
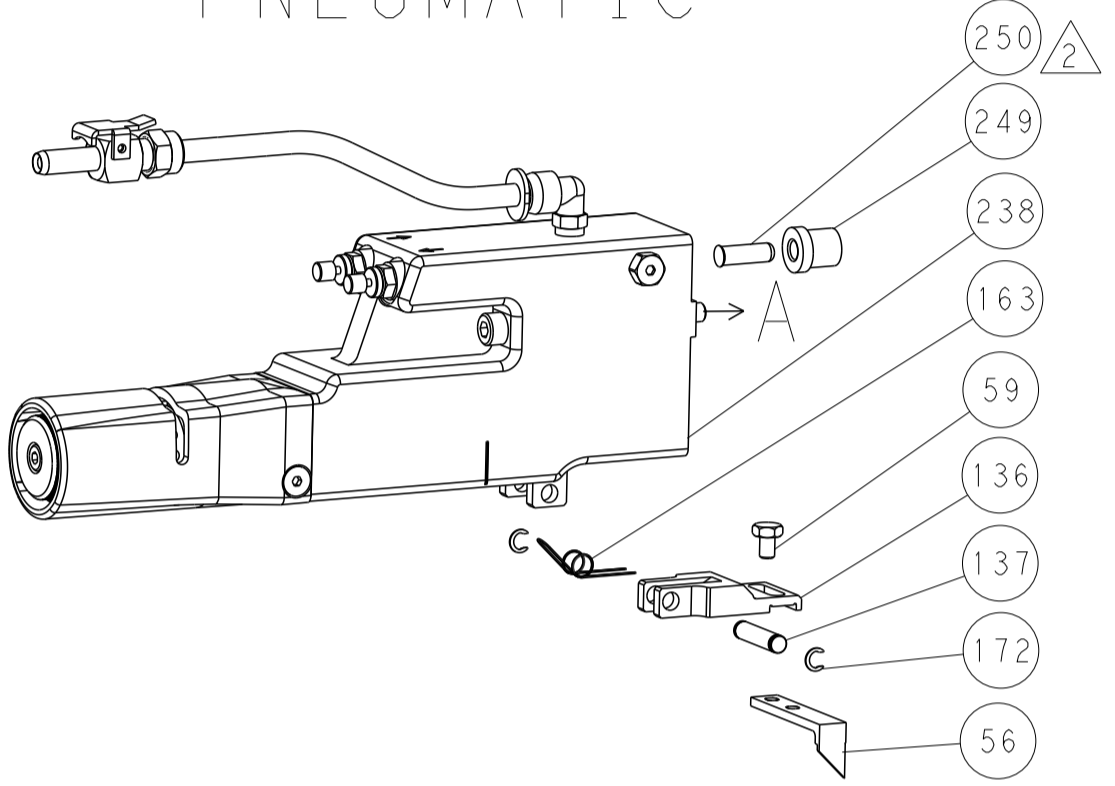

TERMINAL SUPPORT LOCATION

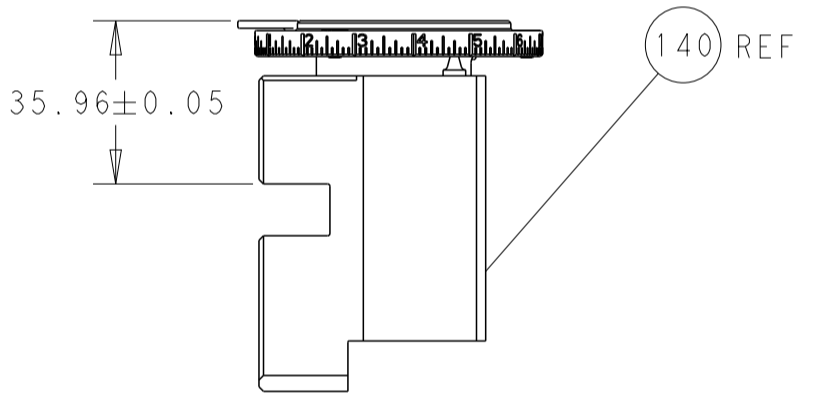

RAM SET-UP

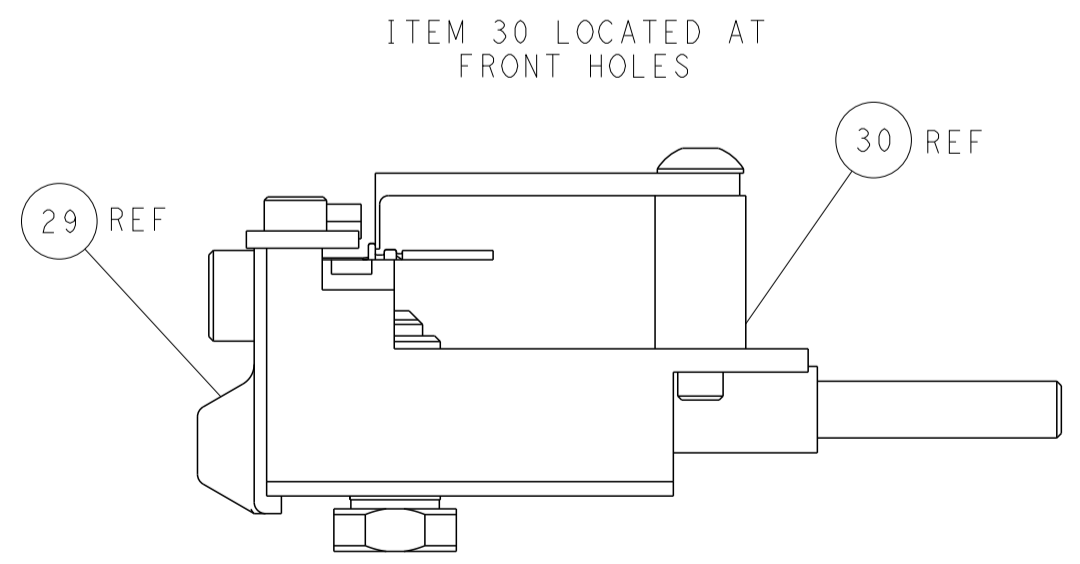
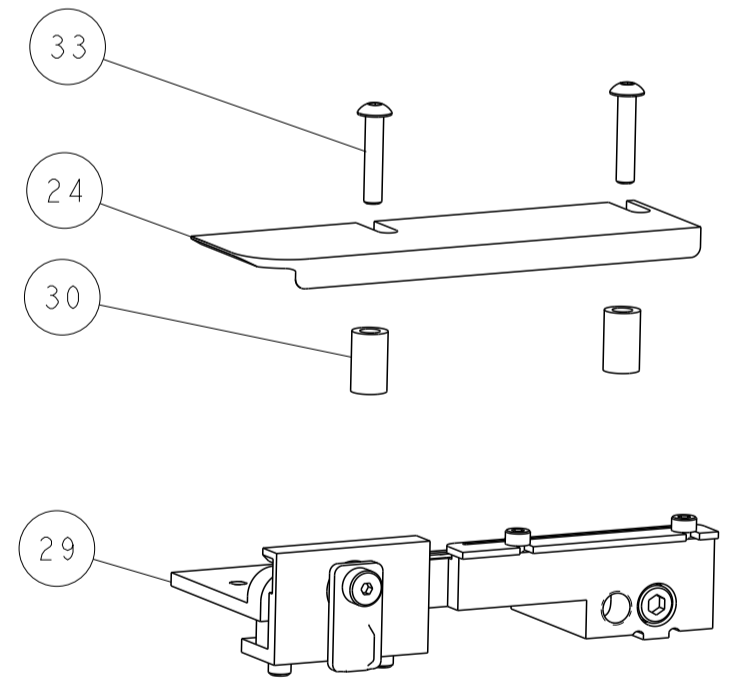

FEED TRACK POSITION GUIDE BY INSULATION BARREL

# CAM POSITIONS

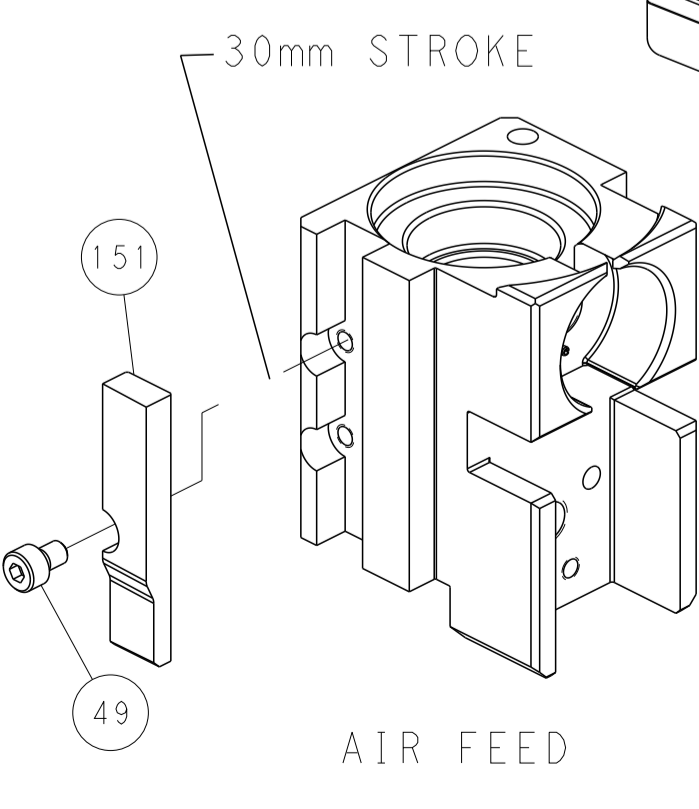
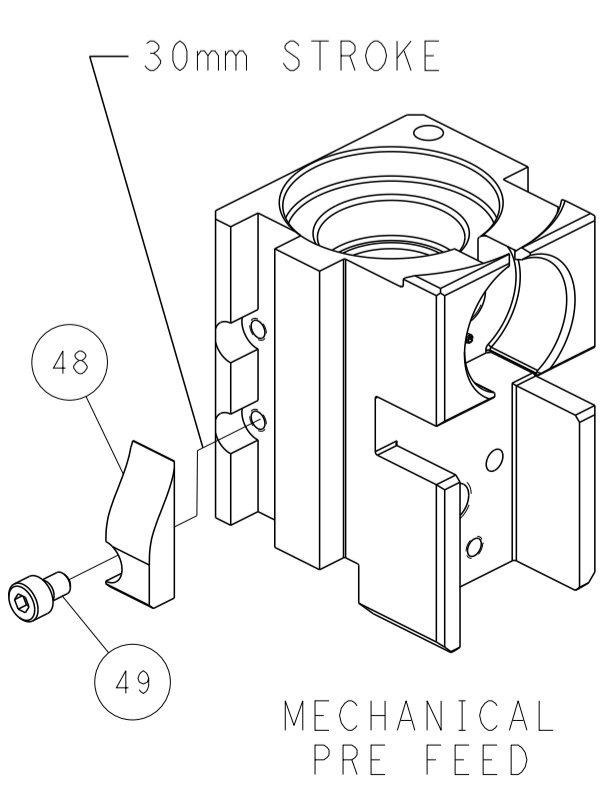
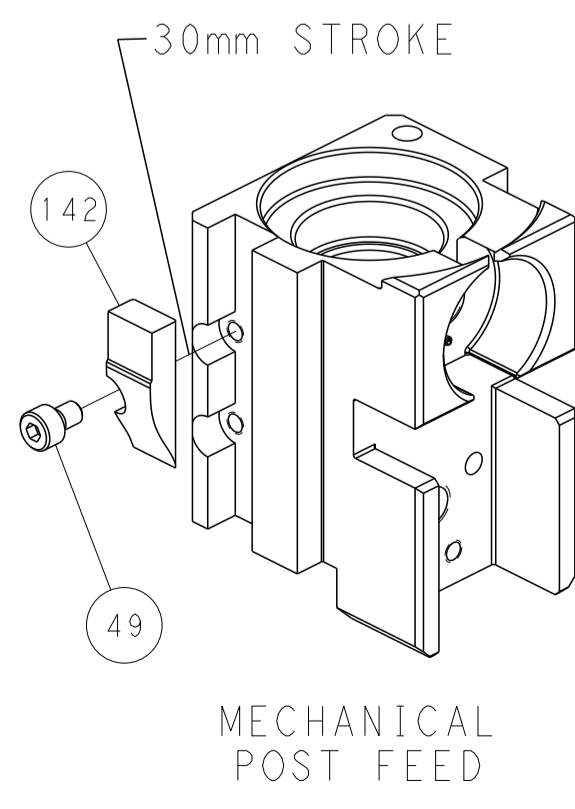

**PACIFIC VERSION**  
 Shown on sheets 3 of 4 & 4 of 4  
 (Atlantic version shown on sheets 1 of 4 & 2 of 4)

DIMENSIONS:		TOLERANCES UNLESS OTHERWISE SPECIFIED:		DWG: B. WEAVER 12OCT2015		TE Connectivity	
mm	0 PLC ±	1 PLC ±	2 PLC ±	3 PLC ±	4 PLC ±	5 PLC ±	Harrisburg, PA 17105-3608
	ANGLES	FINISH		APVD: G. BAILEY 12OCT2015	NAME: Ocean Side Feed Applicator	SIZE: A1	CAGE CODE: 00779
MATERIAL:				PRODUCT SPEC:	APPLICATION SPEC:	SCALE: 1:2	SHEET 4 OF 4
				WEIGHT:	Customer Accessible Production Drawing	REV: C	