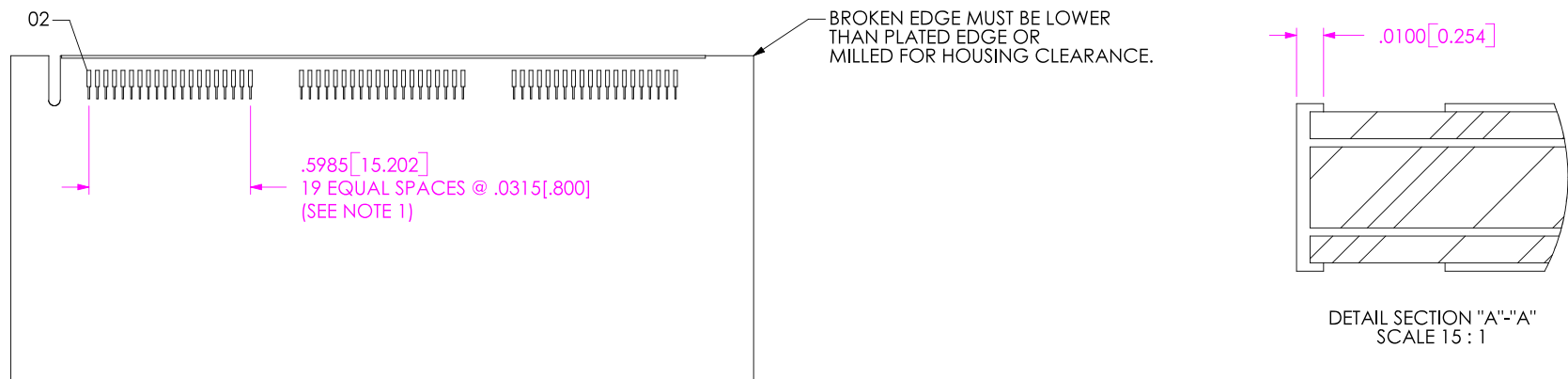

FIG1: RECOMMENDED PCB LAYOUT FOR STANDARD OPTIONS



NOTES:

- 1 BANK = 20 POSITIONS/SIDE FOR STANDARD VERSION.
2. DELETE NOTE
3. PLATED EDGE MAY BE DIVIDED UP IN BANKS DEPENDING UPON DESIGNED FUNCTION.

K



PROPRIETARY NOTE

THIS DOCUMENT CONTAINS INFORMATION CONFIDENTIAL AND PROPRIETARY TO SAMTEC, INC. AND SHALL NOT BE REPRODUCED OR TRANSFERRED TO OTHER DOCUMENTS OR DISCLOSED TO OTHERS OR USED FOR ANY PURPOSE OTHER THAN THAT WHICH IT WAS OBTAINED WITHOUT THE EXPRESSED WRITTEN CONSENT OF SAMTEC, INC.



520 PARK EAST BLVD. NEW ALBANY, IN 47150
 PHONE: 812.944.6733 FAX: 812.948.5047
 e-Mail: INFO@SAMTEC.COM CODE: 55322

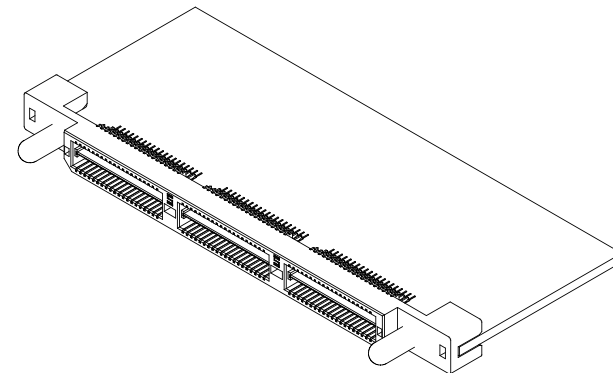
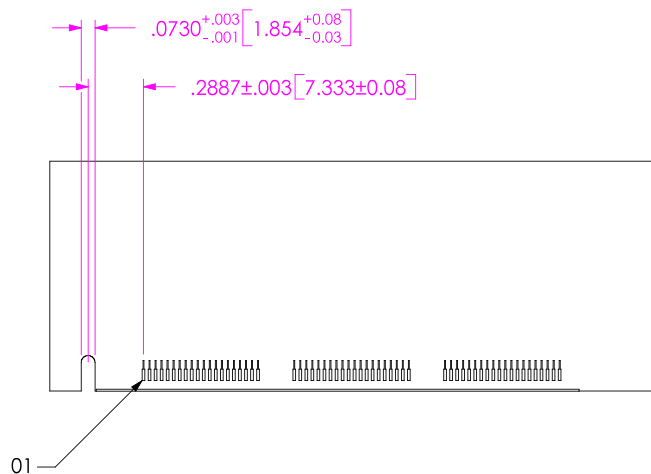
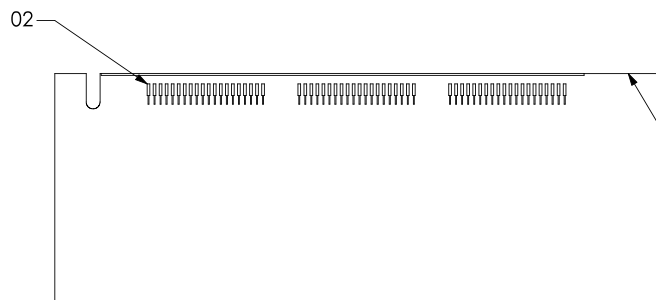
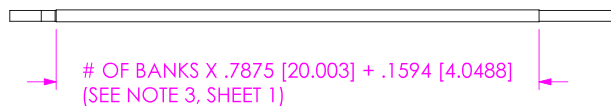

FIG 2: RECOMMENDED PCB LAYOUT FOR -GP OPTIONS

SAME AS FIGURE 1 EXCEPT AS SHOWN



BROKEN EDGE MUST BE LOWER THAN PLATED EDGE OR MILLED FOR HOUSING CLEARANCE.

PROPRIETARY NOTE

THIS DOCUMENT CONTAINS INFORMATION CONFIDENTIAL AND PROPRIETARY TO SAMTEC, INC. AND SHALL NOT BE REPRODUCED OR TRANSFERRED TO OTHER DOCUMENTS OR DISCLOSED TO OTHERS OR USED FOR ANY PURPOSE OTHER THAN THAT WHICH IT WAS OBTAINED WITHOUT THE EXPRESSED WRITTEN CONSENT OF SAMTEC, INC.

DO NOT SCALE DRAWING

SHEET SCALE: 1:1

SAMTEC

520 PARK EAST BLVD, NEW ALBANY, IN 47150
 PHONE: 812.944.6733 FAX: 812.948.5047
 e-Mail: INFO@SAMTEC.COM CODE: 55322

DESCRIPTION: QTE-XXX-01-X-D-EMX

DWG. NO. QTE-EM FOOTPRINT

BY: W. Ouyang2-26-02

SHEET 2 OF 3

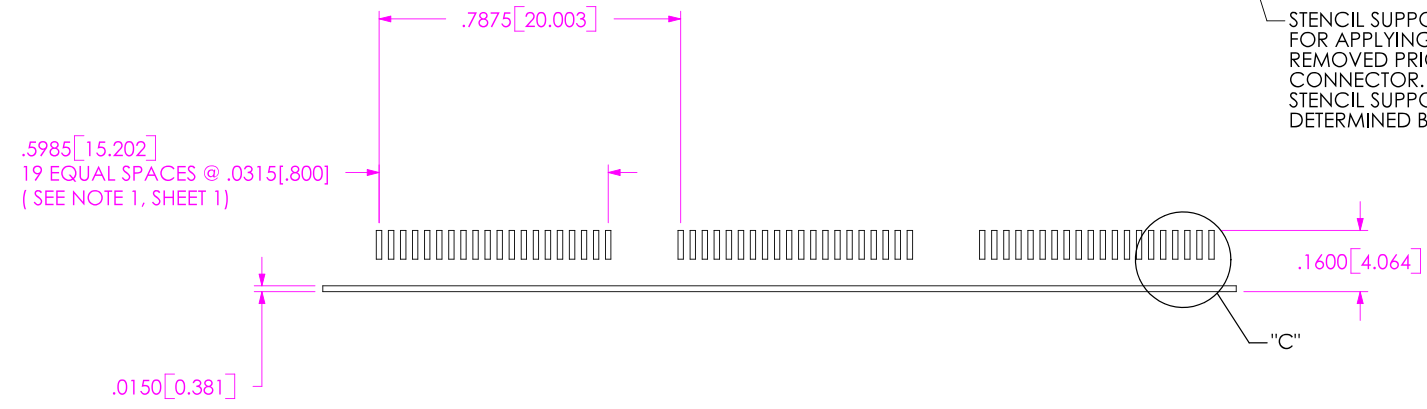
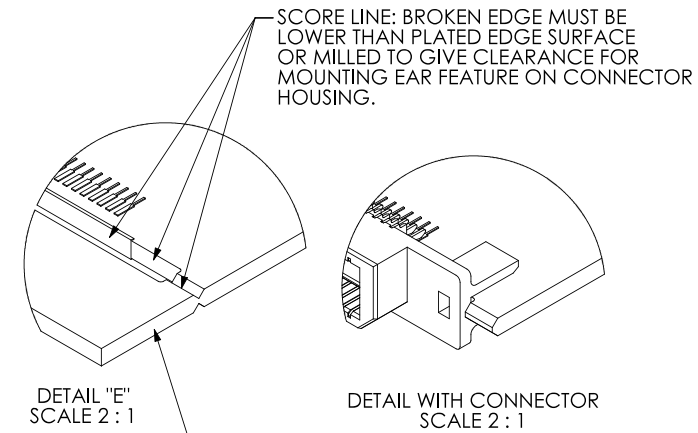
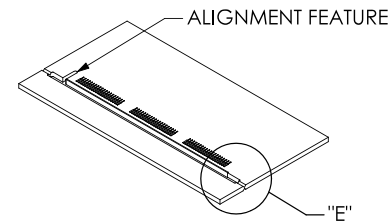
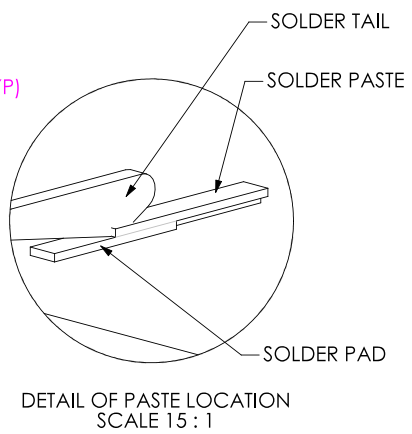
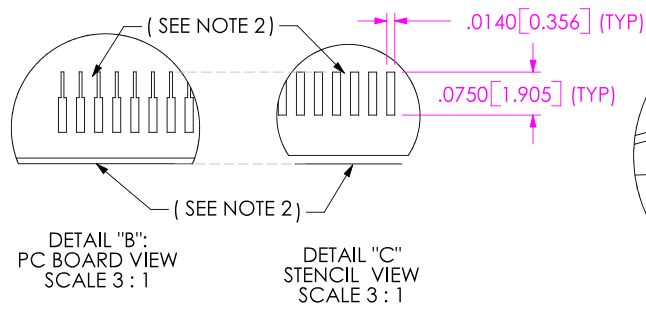

STENCIL SUPPORT TO BE USED FOR APPLYING SOLDER PASTE. REMOVED PRIOR TO APPLYING CONNECTOR. STENCIL SUPPORT AREA TO BE DETERMINED BY CUSTOMER.

NOTE:
1. STENCIL TO BE .0060 [.152] THICK
2. ALIGN EDGES FOR STENCIL APPLICATION.

PROPRIETARY NOTE
THIS DOCUMENT CONTAINS INFORMATION CONFIDENTIAL AND PROPRIETARY TO SAMTEC, INC. AND SHALL NOT BE REPRODUCED OR TRANSFERRED TO OTHER DOCUMENTS OR DISCLOSED TO OTHERS OR USED FOR ANY PURPOSE OTHER THAN THAT WHICH IT WAS OBTAINED WITHOUT THE EXPRESSED WRITTEN CONSENT OF SAMTEC, INC.

SAMTEC
520 PARK EAST BLVD, NEW ALBANY, IN 47150
PHONE: 812.944.6733 FAX: 812.948.5047
e-Mail: INFO@SAMTEC.COM CODE: 55322

