

PART NUMBER	REV	FIRST USED
687944-1	J	122500-1
687944-2	J	565435-5

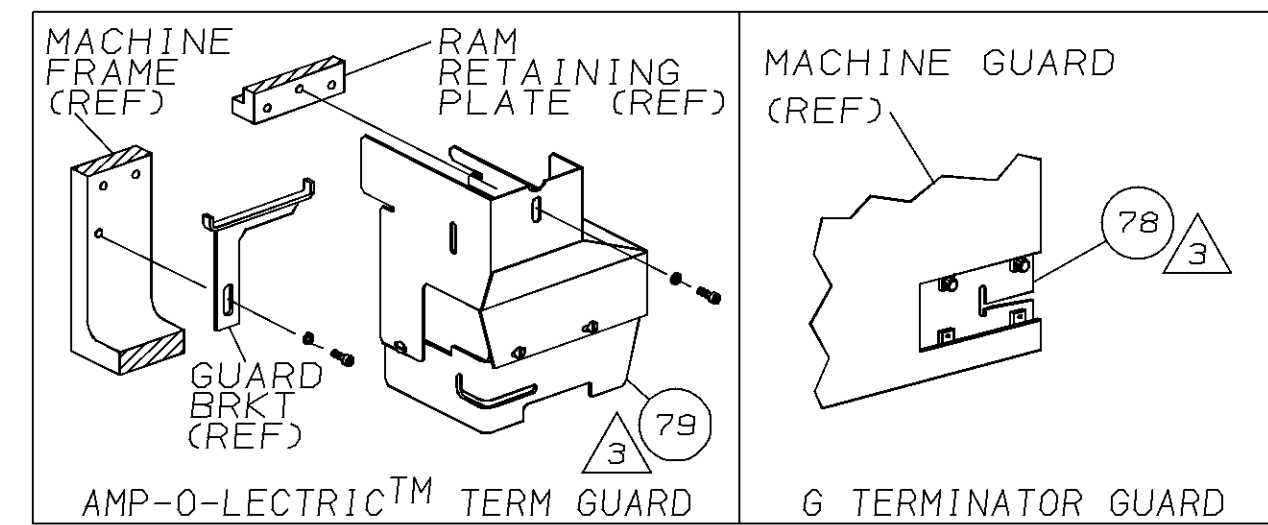

TERMINAL NAME: .312 FASTON™ RECEPTACLE						
42663						
CRIMPING DATA						
PAD LTR	CRIMP HEIGHT		WIRE SIZE			
A	.092 ± .002 [2.34 ± 0.05mm]		12			
B	.084 ± .002 [2.13 ± 0.05mm]		(2) 16			
C	.078 ± .002 [1.98 ± 0.05mm]		14 OR (16 & 18)			
D	.069 ± .002 [1.75 ± 0.05mm]		16			
CRIMP	SIZE	TYPE	RANGE			
WIRE	.110 [2.79mm]	F	16-12			
INSUL	.250 [6.35mm]	F	.160 MAX			
WIRE STRIP LENGTH	TERM APPL	SPEC	FEED	APPL INSTRUCTION	SET UP GAGE	LAYOUT
-	-	-	.966	408-8039	458638-1	200

LEADMAKER & BENCH MODEL G		MECH POST FEED				
BENCH MODEL K		MECH POST FEED				
REF	REF	-	A	22594-8	NUT, HEX	70
REF	REF	-	B	240628-1	PLATE, ADJ	69
REF	REF	-	B	240626-1	SHAFT, PIVOT	68
REF	REF	-	B	240633-1	BUSHING	67
REF	REF	-	A	455680-1	LEVER, INTERMEDIATE	66
REF	REF	-	B	240629-1	BLOCK, PIVOT	65
REF	REF	-	A	240632-2	SCR, ADJ	64
REF	REF	-	B	240659-3	PIN, CAM ROLLER	63
REF	REF	-	B	240658-1	CAM, ROLLER	62
REF	REF	-	B	454398-1	ROD, FEED	61
						60
REF	REF	-	C	454220-1	CAP, RAM	59
REF	REF	-	D	453736-1	HOUSING	58
						57
						56
REF	REF	-	B	240624-1	PIN, FEED FINGER	55
REF	REF	-	B	691499-1	SPRING, FEED FINGER	54
REF	REF	-	B	240635-1	FINGER, FEED	53
REF	REF	-	B	240634-3	LEVER, TERMINAL	52
						51
						50
						49
1	-	-	B	690501-3	CAM, POST FEED 1 1/8 ST	48
-	1	-	B	690501-4	CAM, POST-FEED 1 5/8 ST	47
						46
1	1	-	A	690191-1	PLUG, NYLON	45
1	1	-	C	455674-1	RAM	44
1	1	-	A	690125-1	WASHER, LAMINATED	43
1	1	-	A	690124-1	WASHER, RAM	42
1	1	-	A	7-21002-9	BOLT, CRIMPER (5/16-24x1.00)	41
1	1	-	A	23241-6	BALL, STEEL	40
1	1	-	A	690170-1	SPRING, COMPRESSION	39
1	1	-	C	690142-1	DISC, INSULATION	38
1	1	-	D	354777-1	WIRE DISC, PLASTIC	37
1	1	-	A	22480-5	WASHER, SPRING	36
1	1	-	B	690212-1	POST, RAM	35
						34
						33
1	1	-	D	458980-2	APPLICATOR, BASIC (SUB ASSY)	32
						31
						30
						29
1	1	-	B	3-690451-2	SPACER, STRIPPER	28
1	1	-	A	240639-1	STRIPPER	27
REF	REF	-	C	455676-1	PLATE, BASE	26
2	2	-	A	22354-8	DRAG, STUD	25
1	1	-	B	458803-2	PLATE, STRIP GUIDE	24
1	1	-	C	240825-3	PLATE, STRIP HOLD DOWN	23
2	2	-	A	4-22281-1	SPRING, DRAG	22
						21
1	1	-	A	454177-1	DRAG, STOCK	20
						19
2	2	-	C	454204-3	GUIDE, STRIP (FRONT)	18
REF	REF	-	A	454178-1	GUIDE, FEED ROD	17
REF	REF	-	A	4-22284-9	SPRING, FEED RETURN	16
						15
						14
1	1	-	C	690481-2	SPACER, HOLD DOWN	13
1	1	-	A	23846-1	SPRING, HOLD DOWN	12
1	1	-	B	240833-4	PLATE, REAR SHEAR	11
						10
1	1	-	B	690495-3	PLATE, FRONT SHEAR	9
1	1	-	D	5-240693-4	ANVIL	8
1	1	-	B	2-690474-7	BLADE, SLUG	7
1	1	-	D	2-455892-7	HOLD DOWN, TERMINAL	6
1	1	-	C	2-240641-5	SPACER, SLUG BLADE	5
1	1	-	B	238009-2	SPACER, BLOCK CRIMPER	4
1	1	-	C	2-456134-4	CRIMPER, INSULATION	3
1	1	-	B	455888-4	SPACER, CRIMPER	2
1	1	-	C	456422-1	CRIMPER, WIRE	1

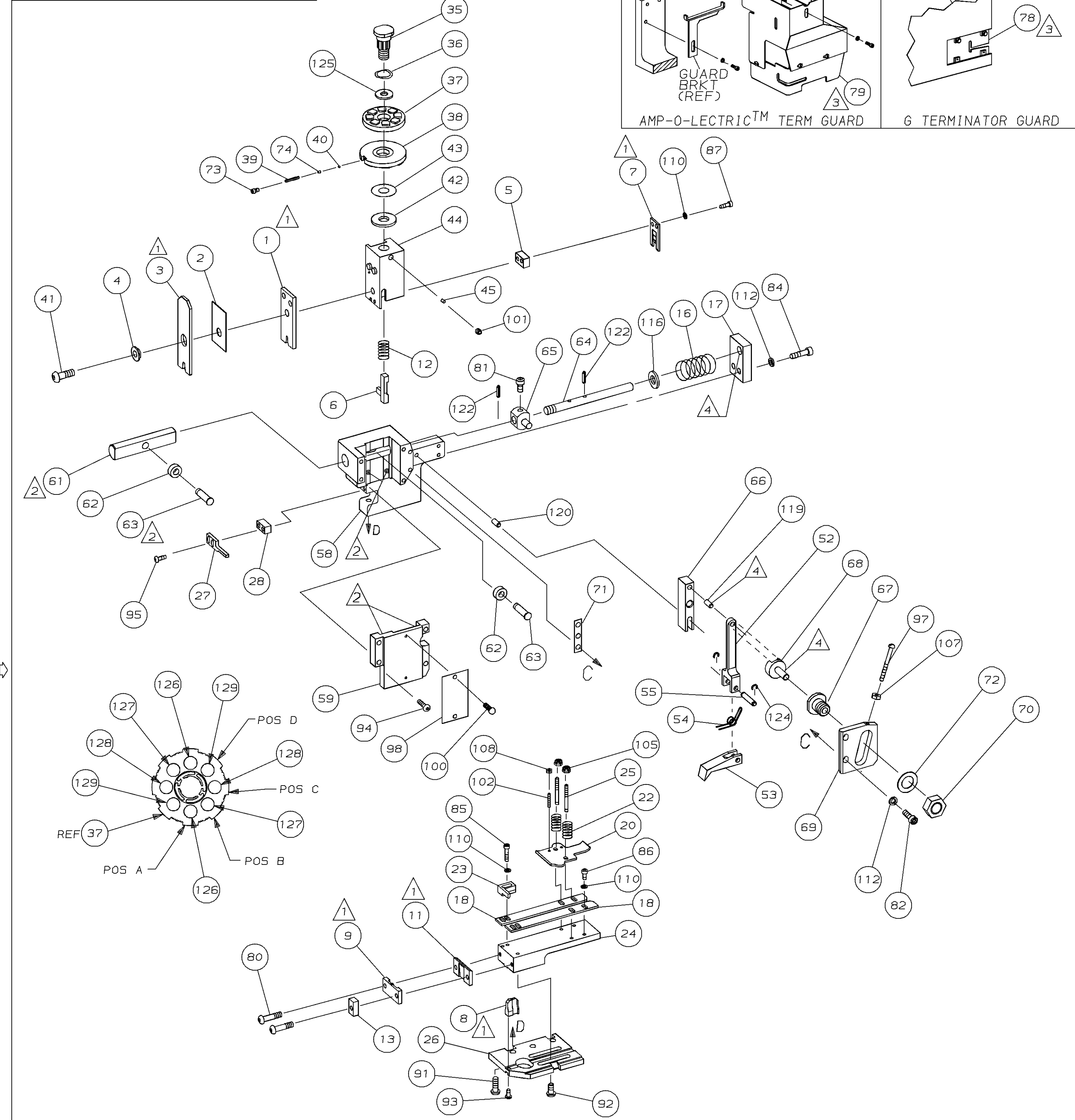

QTY	REV	U/M	DWG SIZE	PART NO	DESCRIPTION	ITEM NO
2	2	-	C	354779-8	PIN, WIRE DISC (.3030)D	129
2	2	-	C	8-354778-7	PIN, WIRE DISC (.2930)C	128
2	2	-	C	7-354778-3	PIN, WIRE DISC (.2860)B	127
2	2	-	C	5-354778-5	PIN, WIRE DISC (.2770)A	126
1	1	-	A	986950-1	WASHER, FLAT PRECISION	125
REF	REF	-	A	21045-3	RING, RET "C" (Ø.187)FD PIN	124
						123
REF	REF	-	A	5-21028-1	PIN, STD SPRING (Ø.12)FD ADJ ROD	122
						121
REF	REF	-	A	1-21030-7	PIN, DOWEL (Ø.187x1.50)HSG	120
REF	REF	-	A	1-21030-1	PIN, DOWEL (Ø.187x.50)LEVER	119
						118
						117
REF	REF	-	A	21899-4	WASHER, FLAT (Ø5/16)SCR ADJ	116
						115
						114
REF	REF	-	A	21024-5	WASHER, LOCK (NO.10)FD ROD GDE	112
7	7	-	A	21024-4	WASHER, LOCK (NO.8)SHEAR BL	110
						109
2	2	-	A	21018-4	NUT, HEX (4-40)DRAG	108
REF	REF	-	A	21018-5	NUT, HEX (6-32)FD ADJ PL	107
						106
2	2	-	A	21022-2	NUT, HEX SL (8-32)DRAG STUD	105
						104
						103
2	2	-	A	2-21006-6	SCR, SKT SET (4-40x.62)DRAG	102
1	1	-	A	21009-2	SCR, SKT SET (1/4-20x.25)RAM	101
2	2	-	A	21017-2	SCR, DRIVE (#2x.19)ID PLATE	100
1	1	-	A	1-21002-7	SCR, BHC (6-32x.38)CAM	99
1	1	-	B	461264-1	PLATE, IDENTIFICATION	98
REF	REF	-	A	6-23715-5	SCR, PAN HD (6-32x1.50)FEED ADJ	97
						96
2	2	-	A	2-21002-2	SCR, BHC (8-32x.50)STRIPPER	95
REF	REF	-	A	2-21002-9	SCR, BHC (10-32x.75)HSG CAP	94
1	1	-	A	22733-8	SCR, BHC (8-32x.38 LW)ANVIL	93
4	4	-	A	3-21002-3	SCR, BHC (1/4-20x.50)ST ØD PL	92
REF	REF	-	A	2-22733-8	SCR, BHC (1/4-20x.62)BASE PL	91
						90
						89
						88
2	2	-	A	2-21000-7	SCR, SHC (8-32x.62)SLUG BLADE	87
3	3	-	A	2-21000-6	SCR, SHC (8-32x.38)STRIP GUIDE	86
2	2	-	A	2-21000-9	SCR, SHC (8-32x.75)R STRIP GUIDE	85
REF	REF	-	A	3-21000-7	SCR, SHC (10-32x.75)FEED ROD GDE	84
						83
REF	REF	-	A	3-21000-6	SCR, SHC (10-32x.62)FEED ADJ PL	82
REF	REF	-	A	3-21000-4	SCR, SHC (10-32x.38)PIVOT BLOCK	81
2	2	-	A	3-21002-0	SCR, BHC (10-32x.88)SHEAR PL	80
REF	-	-	A	455745-1	GUARD, WINDOW	79
-	REF	-	A	679532-1	INSERT, GUARD	78
						77
						76
						75
1	1	-	A	690603-1	SPRING, ASSIST	74
1	1	-	A	23030-1	SCR, SKT CAP (6-32x.25)CP DSC	73
REF	REF	-	A	458109-1	WASHER, FLAT (SPECIAL)	72
REF	REF	-	A	690517-1	SPACER	71

QTY	REV	U/M	DWG SIZE	PART NO	DESCRIPTION	ITEM NO
-2	-1	U/M				
REVISION OF EACH ASSY NO (WHEN BLANK, USE DWG REVISION)						
QTY REQD PER ASSY						
PARTS LIST						
DIMENSIONS IN INCHES. DO NOT SCALE PRINT. TOLERANCES UNLESS OTHERWISE SPECIFIED.						
DR D.SALTZER 6/21/95 APP 6-29-95 T.BEDDICK						
CHK 6-29-95 REL 7/19/95 C.ERISMAN B. MORGAN						
NAME END FEED HDM APPLICATOR MACHINE REF MINI APPL						
SCALE - DWG NO 687944 SHEET 1 OF 1 REV J						

1 RECOMMENDED SPARE PARTS.
 2 GREASE LIGHTLY.
 3 GUARD MUST BE IN PLACE WHEN OPERATING APPLICATOR IN A BENCH MACHINE.
 4 LUBRICATE DAILY USING NO. 20 MACHINE OIL.
 5. ITEMS WITH QTY OF REF SPECIFIED (EXCEPT ITEMS 78 AND 79) ARE USED ON ITEM 32.
 6 ITEM 78 USED WITH G TERMINATOR ONLY.

POST-FEED 1 5/8 STROKE

LOC A LEADMAKER

POST-FEED 1 1/8 STROKE

K TERMINATOR BENCH MACHINE

POST-FEED 1 5/8 STROKE

G TERMINATOR BENCH MACHINE

THIS DRAWING IS A CONTROLLED DOCUMENT FOR AMP INCORPORATED. IT IS SUBJECT TO CHANGE AND THE CONTROLLING ENGINEERING ORGANIZATION SHOULD BE CONTACTED FOR THE LATEST REVISION.

THIS INFORMATION IS CONFIDENTIAL AND IS DISCLOSED TO YOU ON CONDITION THAT NO FURTHER DISCLOSURE IS MADE BY YOU TO OTHER THAN AMP PERSONNEL WITHOUT WRITTEN AUTHORIZATION FROM AMP INCORPORATED, HARRISBURG, PA.