

PART NUMBER	REVISION	DESCRIPTION	FEED TYPE
2151629-1	C	FINE CRIMP HEIGHT ADJUST	MECHANICAL
2151629-2	C	FINE CRIMP HEIGHT ADJUST	PNEUMATIC
7-2151629-1	C	MECHANICAL AND CRIMP TOOLING KIT	MECHANICAL
7-2151629-2	C	PNEUMATIC AND CRIMP TOOLING KIT	PNEUMATIC
7-2151629-7	B	CRIMP TOOLING KIT	-

ATLANTIC VERSION TERMINATOR INTERFACE ADAPTER



APPLICATOR DATA		
CRIMP	SIZE	TYPE
WIRE	1.50 mm [.059]	F
INSUL	1.40 mm [.055]	F

APPLICATOR INSTRUCTIONS  
408-35042

TERMINAL DATA: HIROSE TERMINAL HIROSE CRIMP SPECIFICATION			
TERMINAL NAME: TERMINAL			
WIRE STRIP LENGTH	INSULATION DIAMETER RANGE		
1.68-2.44 mm [.066-.096 IN]	Ø1.20-1.45 mm [.047-.057 IN]		
TERMINAL APPLICATION SPECIFICATION	(A)JCL543-0235-3 Rev 2	-	-
TERMINALS APPLIED			
TE TERMINAL	HIROSE TERMINAL	TE TERMINAL	HIROSE TERMINAL
(A) 1949204-1	(A) DF3-22-SCF		

TERMINAL DATA: HIROSE TERMINAL HIROSE CRIMP SPECIFICATION			
TERMINAL NAME: TERMINAL			
WIRE STRIP LENGTH	INSULATION DIAMETER RANGE		
1.68-2.44 mm [.066-.096 IN]	Ø1.20-1.60 mm [.047-.063 IN]		
TERMINAL APPLICATION SPECIFICATION	(B)JCL543-0861-0 Rev 2	-	-
TERMINALS APPLIED			
TE TERMINAL	HIROSE TERMINAL	TE TERMINAL	HIROSE TERMINAL
(B) 1949204-2	(B) DF3-22-SCFC		

WIRE SIZE	CRIMP HEIGHT mm [INCH]	CRIMP HEIGHT REFERENCE SETTING
22 AWG	0.64 +/- 0.04 [.025 +/- .002]	6.6

WIRE SIZE	CRIMP HEIGHT mm [INCH]	CRIMP HEIGHT REFERENCE SETTING
22 AWG	0.60 +/- 0.04 [.024 +/- .002]	6.9

**\*WARNING**  
ON INSTALLATION, SET WIRE DISC TO CRIMP HEIGHT REFERENCE SETTING FOR LARGEST WIRE SIZE. CRIMP HEIGHT REFERENCE SETTINGS GREATER THAN THE VALUE SHOWN MAY CAUSE DAMAGE TO THE CRIMP TOOLING. REFER TO THE INSTRUCTION SHEET FOR PROPER SETUP AND ADJUSTMENTS.

- RECOMMENDED SPARE PARTS
- REFER TO SUPPLIED INSTRUCTION SHEET FOR CLEANING, LUBRICATION AND STORAGE OF APPLICATOR.
- APPLY PART NUMBER 2-23419-6 LOCTITE TO THREADS OF ITEM 242.
- CRIMP HEIGHT REFERENCE SETTING WAS THE SETTING USED WHEN THE APPLICATOR WAS QUALIFIED AT THE FACTORY. ADJUSTMENT MAY BE NECESSARY WHEN RUNNING APPLICATOR IN THE FIELD.
- UNLESS SPECIFIED OTHERWISE TORQUE VALUES SHALL BE USED PER DOCUMENT, 101-35000.

LOC	DIST	REVISIONS					
A	66	P	LTN	DESCRIPTION	DATE	DWN	APVD
		A		RELEASED	16JUN2014	LG	TE
		B		ECR-15-016803	17NOV2015	XZ	TE
		C		ECR-18-005584	07APR2019	TB	CT

-	1	-	1	-	2119640-1	PUSH ROD, AIR FEED	250
-	1	-	1	-	1803259-1	BUSHING, FLANGED	249
-	1	-	1	-	2119641-1	FEED CAM, AIR FEED	248
-	1	1	1	1	2119082-4	CAM, SNAIL, INSULATION ADJUSTMENT	244
-	1	1	1	1	2079764-1	WASHER, WAVE SPRING, CREST-TO-CREST	243
-	1	1	1	1	2119083-1	RETAINER, INSULATION DIAL	242
-	1	1	1	1	7-18023-7	SCR, SKT HD CAP M3 X 4.0	241
-	-	1	-	1	2119580-1	MECHANICAL FEED ASSEMBLY	239
-	1	-	1	-	2063440-1	AIR FEED MODULE	238
-	2	-	2	-	21045-3	RING, RETAIN, EXTERN, 3/16 CRESCENT	172
-	REF	REF	REF	REF	994970-2	COUNTER, MAGNETIC	164
-	1	-	1	-	240638-1	SPRING, FEED FINGER	163
-	1	-	1	-	3-23627-7	PIN, RETAIN, GRVD, 3/16 X .854	137
-	1	-	1	-	2119799-1	HOLDER, FEED FINGER, AF	136
-	1	1	1	1	2844908-1	SCREW, LOCKING	99
-	1	1	1	1	2844907-1	POST, LOCKING	98
-	1	1	1	1	1-455888-2	SPACER, CRIMPER	82
-	1	1	1	1	5-547505-2	SPRING, COMPRESSION	77
-	1	1	1	1	854769-4	HOLDER, INS	74
-	1	1	1	1	1803607-1	DOCUMENTATION PACKAGE	71
-	1	1	1	1	2119740-1	TAG, IDENTIFICATION	67
-	2	2	2	2	2168078-1	SCREW, DRIVE, RH, RoHS, 2 x .188	66
-	1	1	1	1	2168083-2	SCR, SKT HD CAP, RoHS, M4 X 8.0	60
-	1	1	1	1	5-18022-5	SCR, HEX HD CAP, M4 X 6.0	59
-	1	1	1	1	21028-2	PIN, SLOTTED SPRING .062 X .250	58
-	1	1	1	1	1338685-1	PAWL, FEED	56
-	4	4	4	4	2168083-3	SCR, SKT HD CAP, RoHS, M4 X 12.0	54
-	1	2	1	2	18023-9	SCR, SKT HD CAP M4 X 6.0	49
-	-	1	-	1	2119652-1	FEED CAM, PRE FEED	48
-	-	1	-	1	2119653-1	FEED CAM, POST FEED	47
-	1	1	1	1	1803583-9	APPLICATOR BASIC ASSEMBLY, SF	46
-	1	1	1	1	1803515-1	RAM ASSEMBLY, SF ATLANTIC	44
-	1	1	1	1	1803602-1	SCR, BHSC, RoHS (M8 X 25)	41
-	1	1	1	1	2-1752356-3	SUPPORT, TERMINAL	34
-	2	2	2	2	2079383-5	SCR, BHSC, RoHS (M4 X 20)	33
-	2	2	2	2	2-2844962-4	SPACER, CYLINDRICAL, STRIP GUIDE	30
-	1	1	1	1	2844992-1	ASSEMBLY, STRIP GUIDE	29
-	1	1	1	1	455888-3	SPACER, CRIMPER	28
-	1	1	1	1	1320928-2	STRIP GUIDE	24
-	1	1	1	1	2168083-2	SCR, SKT HD CAP, RoHS, M4 X 8.0	21
-	2	2	2	2	1-18028-2	WASHER, FLAT, REG M4	20
-	1	1	1	1	2119533-1	STRIPPER, SIDE FEED	19
-	1	1	1	1	2119806-1	INSERT, SHEAR	13
-	1	1	1	1	3-22280-3	SPRING, COMPRESSION	12
-	1	1	1	1	1-356885-4	STOP, SHEAR	11
-	1	1	1	1	2119805-1	SHEAR HOLDER, FRONT	10
-	1	1	1	1	1633861-3	SHEAR, FLOATING	9
-	1	2	2	1	1803334-3	ANVIL, COMBINATION	8
-	-	-	-	-	-	-	7
-	-	-	-	-	-	-	6
-	1	1	1	1	2119780-4	DEPRESSOR, SHEAR	5
-	1	1	1	1	2-238011-0	BLOCK, CRIMPER SPACER	4
-	1	2	2	1	1-1803326-5	CRIMPER, INSULATION F	3
-	1	1	1	1	455888-1	SPACER, CRIMPER	2
-	1	2	2	1	1803324-5	CRIMPER, WIRE	1

ATLANTIC VERSION  
Shown on sheets 1 of 4 & 2 of 4  
(Pacific version shown on sheets 3 of 4 & 4 of 4)

DIMENSIONS:		TOLERANCES UNLESS OTHERWISE SPECIFIED:		MATERIAL:		FINISH:	
mm	0 PLC ±	1 PLC ±	2 PLC ±	3 PLC ±	4 PLC ±	ANGLES ±	FINISH ±

OWN	R. KNEPPER	11-Jun-14
CHK	T. ELBIN	11-Jun-14
APVD	M. CLIFFORD	11-Jun-14

NAME	Ocean Side Feed Applicator	
SIZE	CAGE CODE	DRAWING NO
A1	00779	2151629

Customer Accessible Production Drawing SCALE 1:2 SHEET 1 OF 4 REV C

LOC	DIST	REVISIONS					
A	66	P	LTN	DESCRIPTION	DATE	OWN	APVD
		-		SEE SHEET 1			

# FEED TYPE MECHANICAL

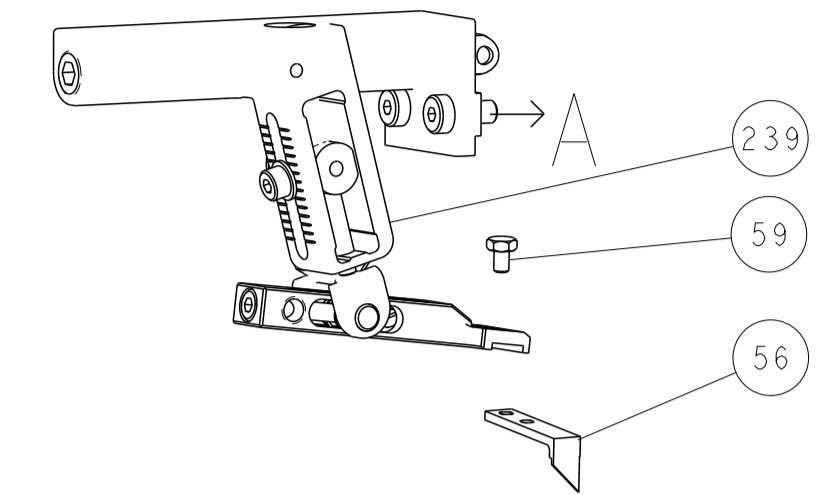

# PNEUMATIC

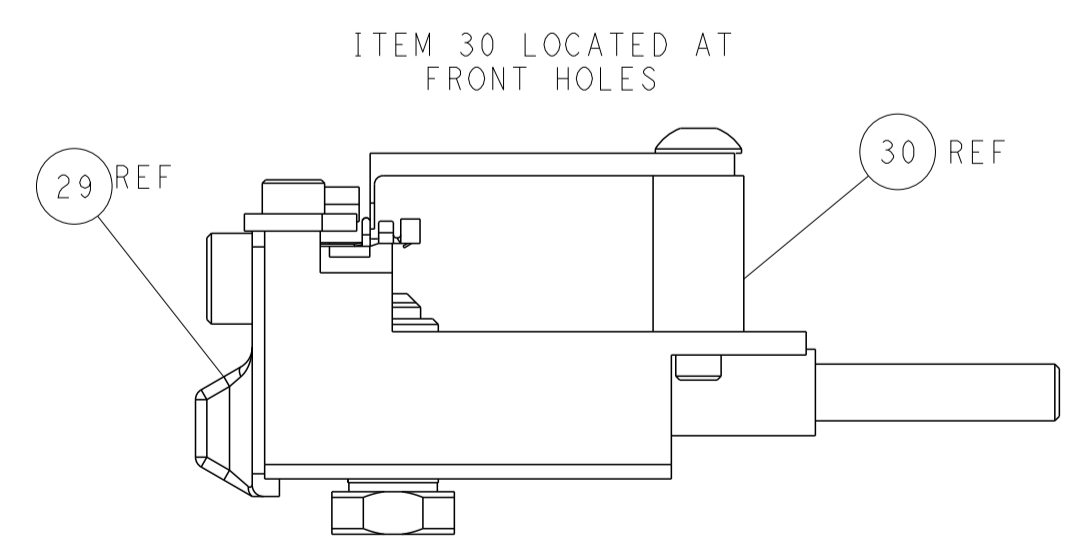
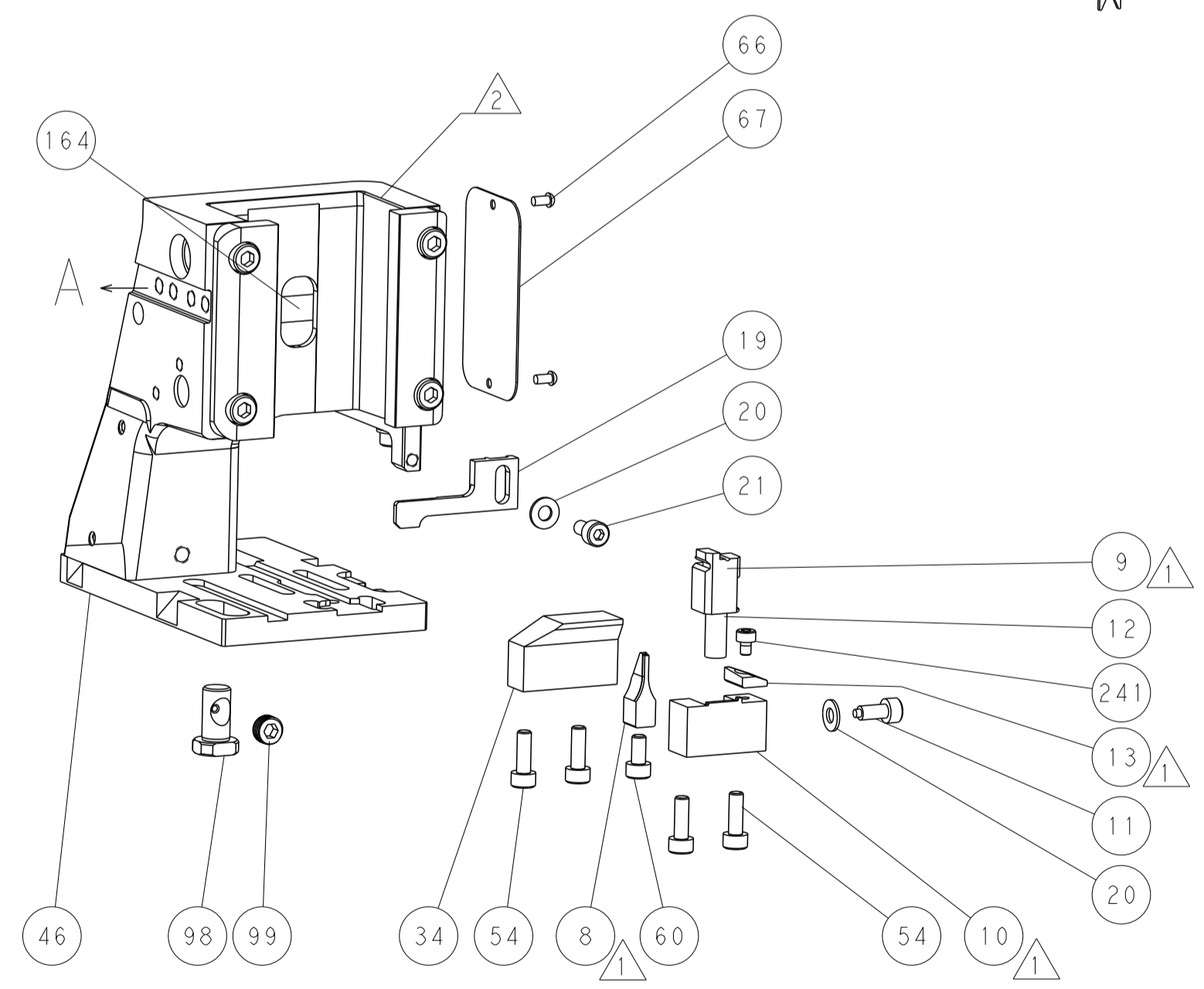
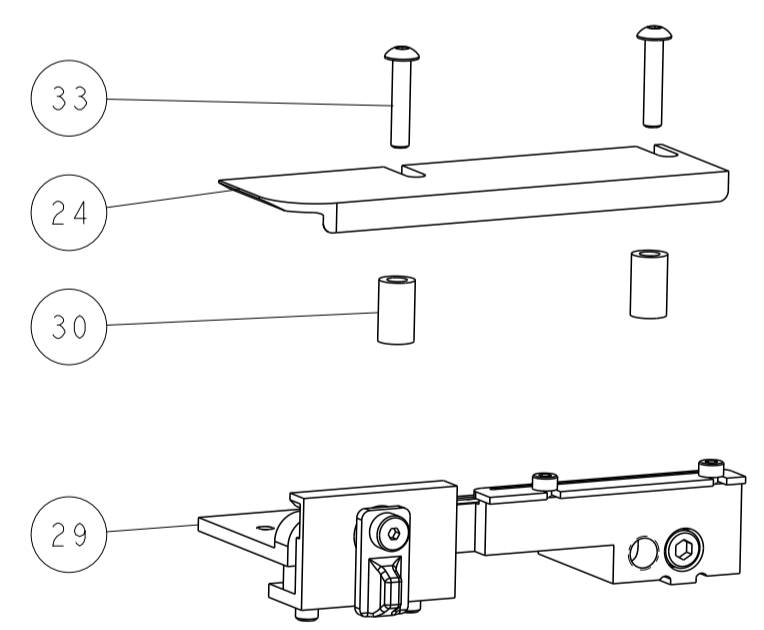
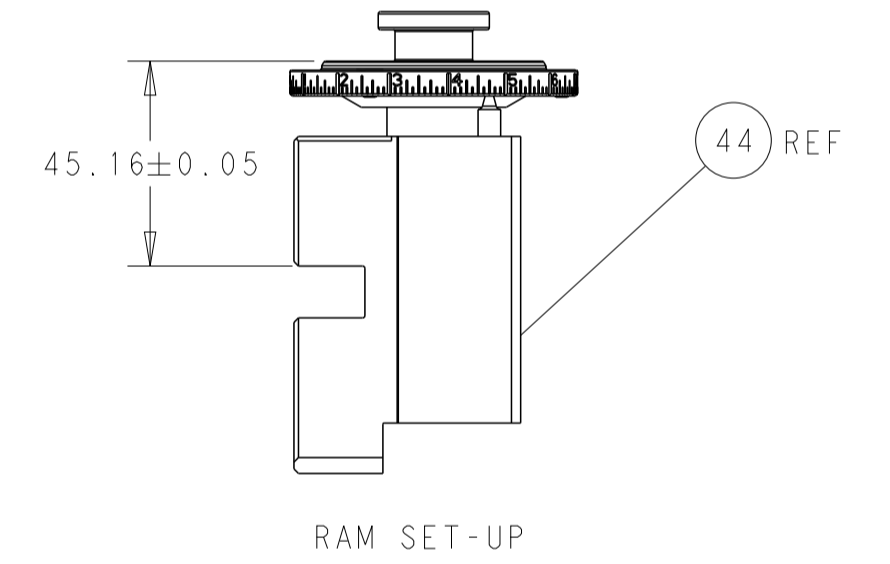
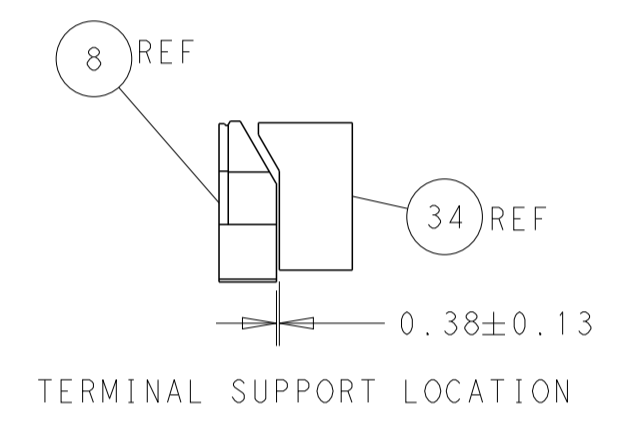
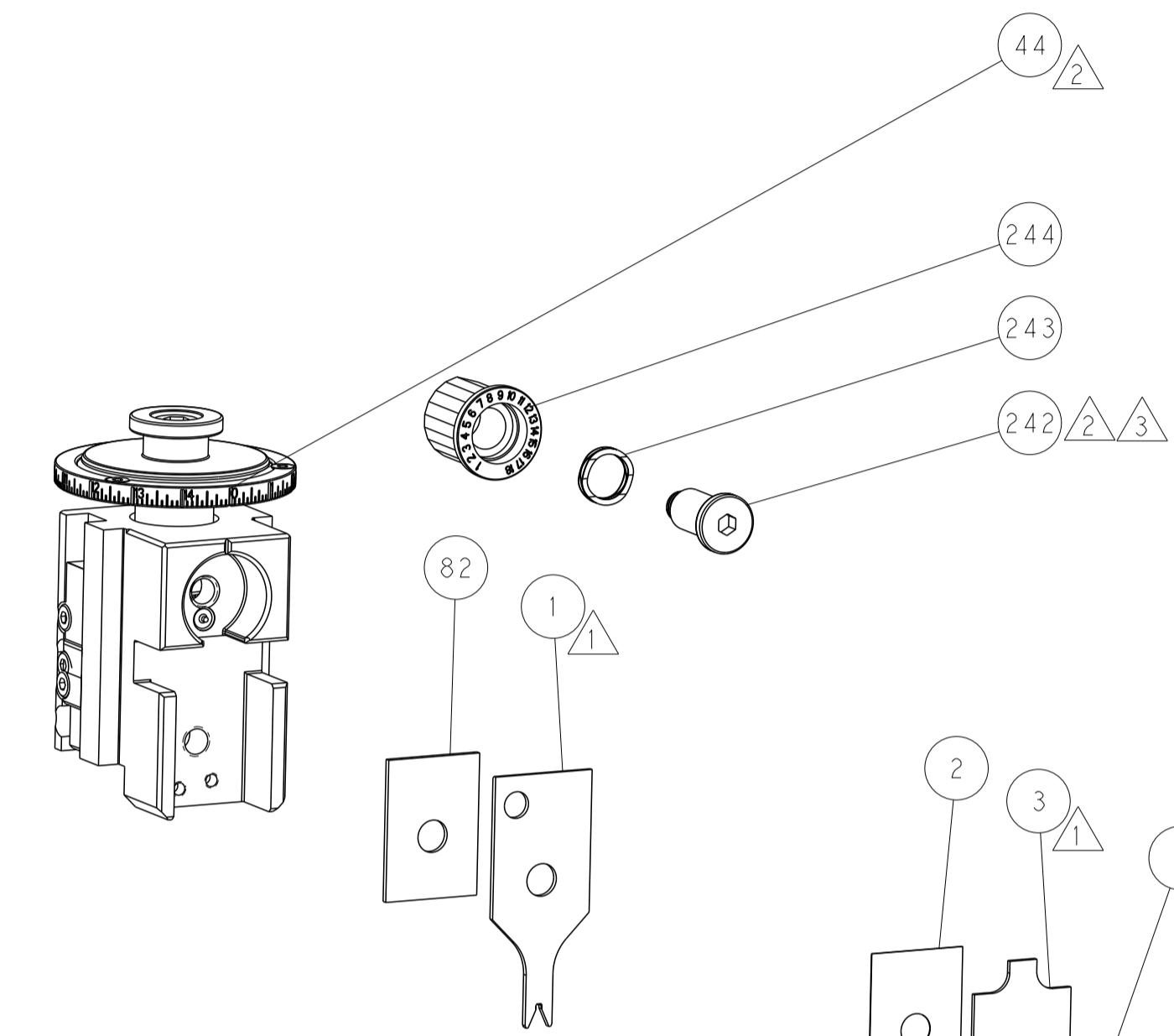
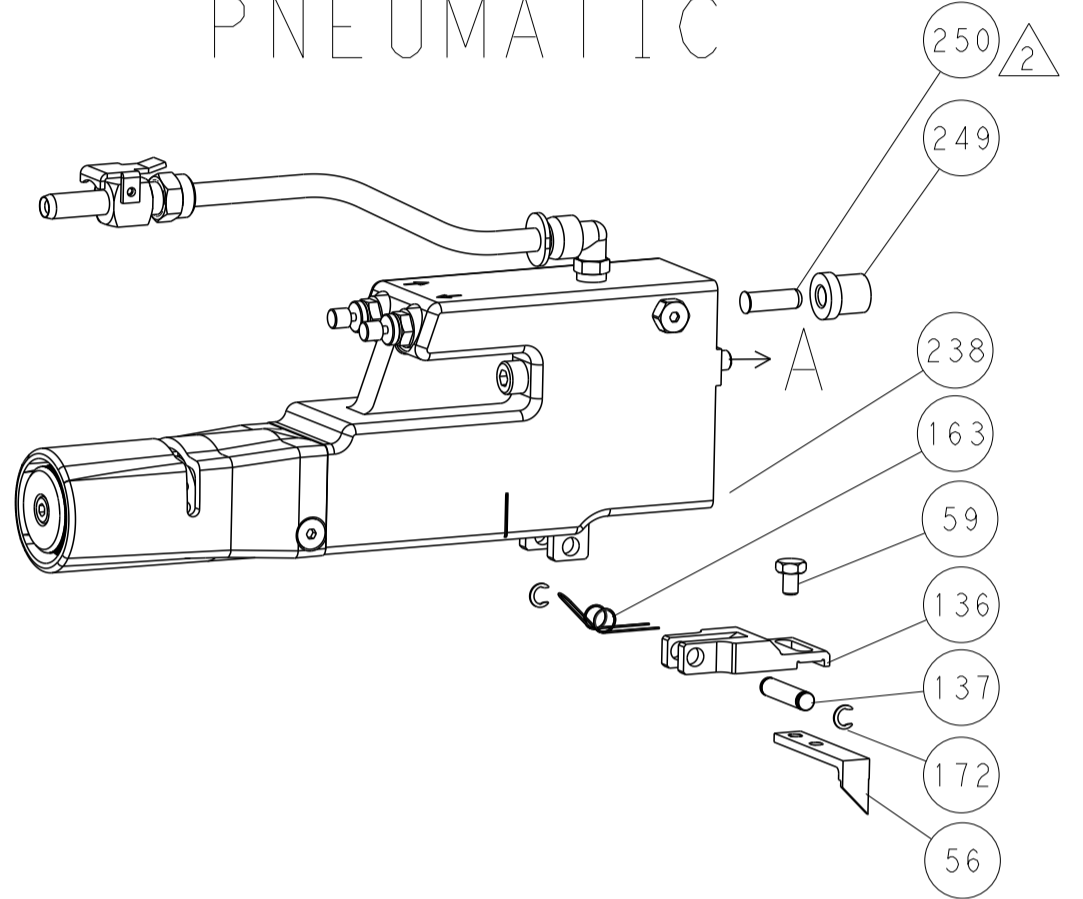

# CAM POSITIONS

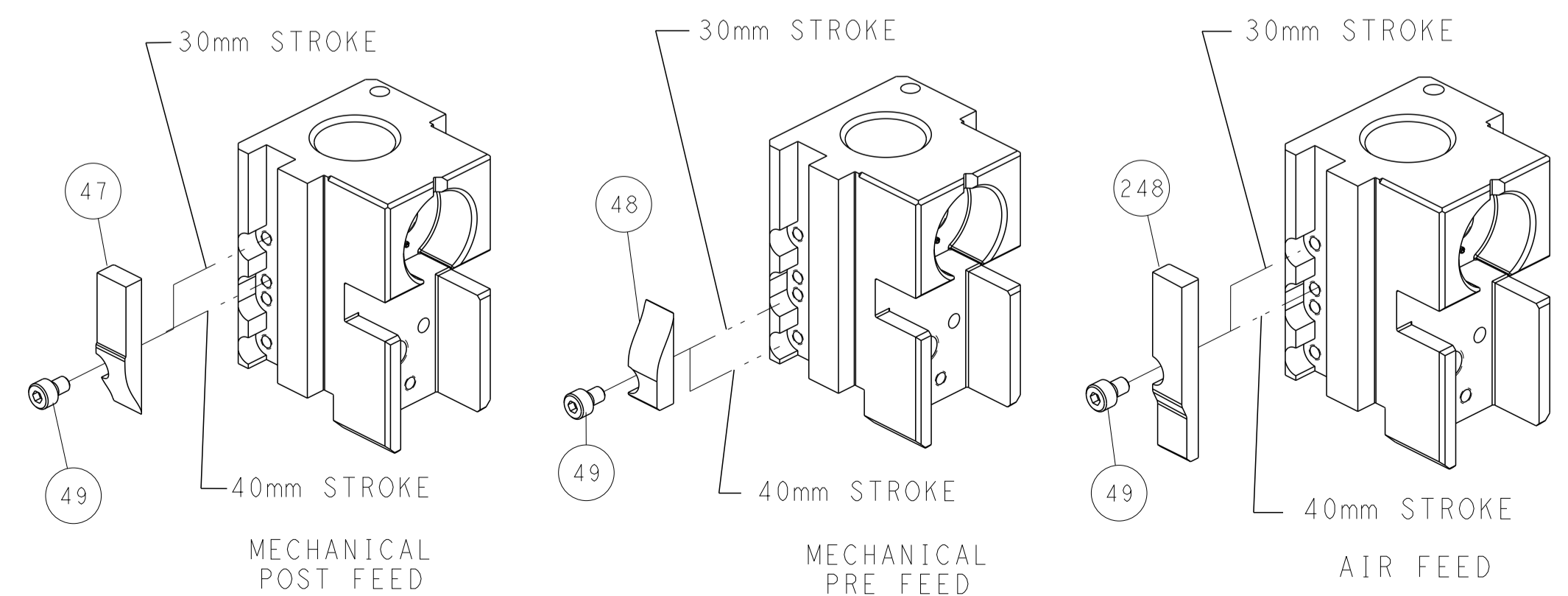

**ATLANTIC VERSION**  
 Shown on sheets 1 of 4 & 2 of 4  
 (Pacific version shown on sheets 3 of 4 & 4 of 4)

DIMENSIONS: mm 		TOLERANCES UNLESS OTHERWISE SPECIFIED: 0 PLC ± 1 PLC ± 2 PLC ± 3 PLC ± 4 PLC ± ANGLES ±		DWN R. KNEPPER 11-Jun-14 CHK T. ELBIN 11-Jun-14 APVD M. CLIFFORD 11-Jun-14 PRODUCT SPEC APPLICATION SPEC WEIGHT Customer Accessible Production Drawing		NAME Ocean Side Feed Applicator SIZE CAGE CODE DRAWING NO. A1 00779 C=2151629 SCALE 1:2 SHEET 1 of 4 REV C	
MATERIAL: FINISH:				RESTRICTED TO:		SHEETS 3 & 4 ARE NOT REQUIRED FOR ATLANTIC VERSION	

PART NUMBER	REVISION	DESCRIPTION	FEED TYPE
2-2151629-1	C	FINE CRIMP HEIGHT ADJUST	MECHANICAL
2-2151629-2	C	FINE CRIMP HEIGHT ADJUST	PNEUMATIC
7-2151629-7	B	CRIMP TOOLING KIT	-

PACIFIC VERSION TERMINATOR  
INTERFACE ADAPTER



APPLICATOR DATA		
CRIMP	SIZE	TYPE
WIRE	1.50 mm [.059]	F
INSUL	1.40 mm [.055]	F
APPLICATOR INSTRUCTIONS 408-35042		

TERMINAL DATA: HIROSE TERMINAL HIROSE CRIMP SPECIFICATION			
TERMINAL NAME: TERMINAL			
WIRE STRIP LENGTH		INSULATION DIAMETER RANGE	
1.68-2.44 mm [.066-.096 IN]		Ø1.20-1.45 mm [.047-.057 IN]	
TERMINAL APPLICATION SPECIFICATION	(A)CL543-0235-3 Rev 2	-	-
TERMINALS APPLIED			
TE TERMINAL	HIROSE TERMINAL	TE TERMINAL	HIROSE TERMINAL
(A) 1949204-1	(A) DF3-22-SCF		

TERMINAL DATA: HIROSE TERMINAL HIROSE CRIMP SPECIFICATION			
TERMINAL NAME: TERMINAL			
WIRE STRIP LENGTH		INSULATION DIAMETER RANGE	
1.68-2.44 mm [.066-.096 IN]		Ø1.20-1.60 mm [.047-.063 IN]	
TERMINAL APPLICATION SPECIFICATION	(B)CL543-0861-0 Rev 2	-	-
TERMINALS APPLIED			
TE TERMINAL	HIROSE TERMINAL	TE TERMINAL	HIROSE TERMINAL
(B) 1949204-2	(B) DF3-22-SCFC		

WIRE SIZE	CRIMP HEIGHT mm [INCH]	CRIMP HEIGHT REFERENCE SETTING
22 AWG	0.64+/-0.04 [.025+/- .002]	6.6

WIRE SIZE	CRIMP HEIGHT mm [INCH]	CRIMP HEIGHT REFERENCE SETTING
22 AWG	0.60+/-0.04 [.024+/- .002]	6.9

**\*WARNING**  
ON INSTALLATION, SET WIRE DISC TO CRIMP HEIGHT REFERENCE SETTING FOR LARGEST WIRE SIZE. CRIMP HEIGHT REFERENCE SETTINGS GREATER THAN THE VALUE SHOWN MAY CAUSE DAMAGE TO THE CRIMP TOOLING. REFER TO THE INSTRUCTION SHEET FOR PROPER SETUP AND ADJUSTMENTS.

- RECOMMENDED SPARE PARTS
- REFER TO SUPPLIED INSTRUCTION SHEET FOR CLEANING, LUBRICATION AND STORAGE OF APPLICATOR.
- APPLY PART NUMBER 2-23419-6 LOCTITE TO THREADS OF ITEM 242.
- CRIMP HEIGHT REFERENCE SETTING WAS THE SETTING USED WHEN THE APPLICATOR WAS QUALIFIED AT THE FACTORY. ADJUSTMENT MAY BE NECESSARY WHEN RUNNING APPLICATOR IN THE FIELD.
- 5. UNLESS SPECIFIED OTHERWISE TORQUE VALUES SHALL BE USED PER DOCUMENT, 101-35000.

LOC	DIST	REVISIONS					
A	66	P	LTN	DESCRIPTION	DATE	OWN	APVD
-	-	-	-	SEE SHEET 1	-	-	-

-	1	-	2119640-1	PUSH ROD, AIR FEED	250
-	1	-	1803259-1	BUSHING, FLANGED	249
-	1	1	2119082-4	CAM, SNAIL, INSULATION ADJUSTMENT	244
-	1	1	2079764-1	WASHER, WAVE SPRING, CREST-TO-CREST	243
-	1	1	2119083-1	RETAINER, INSULATION DIAL	242
-	1	1	7-18023-7	SCR, SKT HD CAP M3 X 4.0	241
-	-	1	2119580-1	MECHANICAL FEED ASSEMBLY	239
-	1	-	2063440-1	AIR FEED MODULE	238
-	2	-	21045-3	RING, RETAIN, EXTERN, 3/16 CRESCENT	172
-	REF	REF	994970-2	COUNTER, MAGNETIC	164
-	1	-	240638-1	SPRING, FEED FINGER	163
-	1	-	2119641-2	FEED CAM, AIR FEED	151
-	1	1	2168083-8	SCR, SKT HD CAP, RoHS, M4 X 16	144
-	4	4	2168083-9	SCR, SKT HD CAP, RoHS, M4 X 20	143
-	-	1	2119653-2	FEED CAM, POST FEED	142
-	1	1	1-1803583-0	APPLICATOR BASIC ASSEMBLY, SF	141
-	1	1	1803516-1	RAM ASSEMBLY, SF PACIFIC	140
-	1	-	3-23627-7	PIN, RETAIN, GRVD, 3/16 X .854	137
-	1	-	2119799-1	HOLDER, FEED FINGER, AF	136
-	1	1	2844908-1	SCREW, LOCKING	99
-	1	1	2844907-1	POST, LOCKING	98
-	1	1	1-455888-2	SPACER, CRIMPER	82
-	1	1	5-547505-2	SPRING, COMPRESSION	77
-	1	1	854769-4	HOLDER, INS	74
-	1	1	1803607-1	DOCUMENTATION PACKAGE	71
-	1	1	2119740-1	TAG, IDENTIFICATION	67
-	2	2	2168078-1	SCREW, DRIVE, RH, RoHS, 2 x .188	66
-	1	1	5-18022-5	SCR, HEX HD CAP, M4 X 6.0	59
-	1	1	21028-2	PIN, SLOTTED SPRING .062 X .250	58
-	1	1	1338685-1	PAWL, FEED	56
-	1	2	18023-9	SCR, SKT HD CAP M4 X 6.0	49
-	-	1	2119652-1	FEED CAM, PRE FEED	48
-	1	1	1803602-1	SCR, BHSC, RoHS (M8 X 25)	41
-	1	1	2-1752356-3	SUPPORT, TERMINAL	34
-	2	2	2079383-5	SCR, BHSC, RoHS (M4 X 20)	33
-	2	2	2-2844962-4	SPACER, CYLINDRICAL, STRIP GUIDE	30
-	1	1	2844992-1	ASSEMBLY, STRIP GUIDE	29
-	1	1	455888-3	SPACER, CRIMPER	28
-	1	1	1320928-2	STRIP GUIDE	24
-	1	1	2168083-2	SCR, SKT HD CAP, RoHS, M4 X 8.0	21
-	2	2	1-18028-2	WASHER, FLAT, REG M4	20
-	1	1	2119533-1	STRIPPER, SIDE FEED	19
-	1	1	2119806-1	INSERT, SHEAR	13
-	1	1	3-22280-3	SPRING, COMPRESSION	12
-	1	1	1-356885-4	STOP, SHEAR	11
-	1	1	2119805-1	SHEAR HOLDER, FRONT	10
-	1	1	1633861-3	SHEAR, FLOATING	9
-	1	1	1803334-3	ANVIL, COMBINATION	8
-	-	-	-	-	7
-	-	-	-	-	6
-	1	1	2119780-4	DEPRESSOR, SHEAR	5
-	1	1	2-238011-0	BLOCK, CRIMPER SPACER	4
-	1	1	1-1803326-5	CRIMPER, INSULATION F	3
-	1	1	455888-1	SPACER, CRIMPER	2
-	1	1	1803324-5	CRIMPER, WIRE	1

PACIFIC VERSION  
Shown on sheets 3 of 4 & 4 of 4  
(Atlantic version shown on sheets 1 of 4 & 2 of 4)

DIMENSIONS:		TOLERANCES UNLESS OTHERWISE SPECIFIED:		MATERIAL:		FINISH:	
mm	0 PLC ±	1 PLC ±	2 PLC ±	3 PLC ±	4 PLC ±	ANGLES ±	FINISH ±
				DWG: R. KNEPPER 11-Jun-14 CHK: T. ELBIN 11-Jun-14 APVD: M. CLIFFORD 11-Jun-14 PRODUCT SPEC APPLICATION SPEC WEIGHT SCALE: 1:2 SHEET 1 OF 4 REV C			

LOC	DIST	REVISIONS					
A	66	P	LTN	DESCRIPTION	DATE	OWN	APVD
		-		SEE SHEET 1	-	-	-

# FEED TYPE MECHANICAL

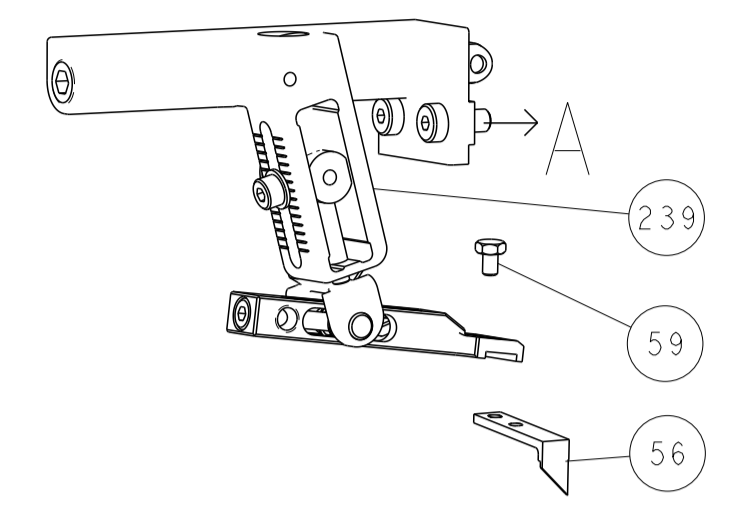

# PNEUMATIC

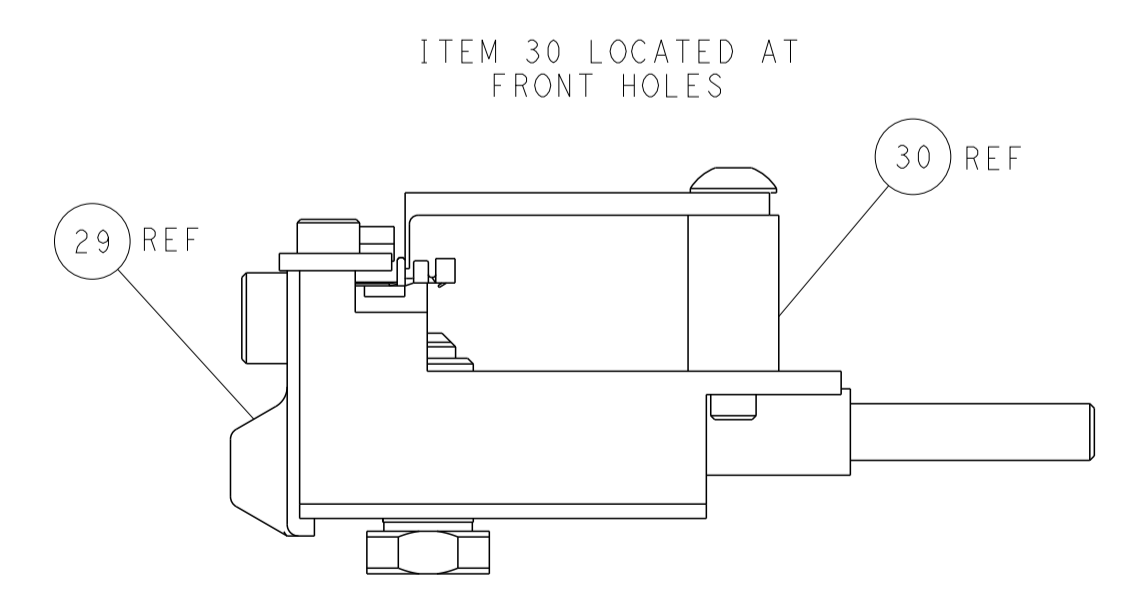
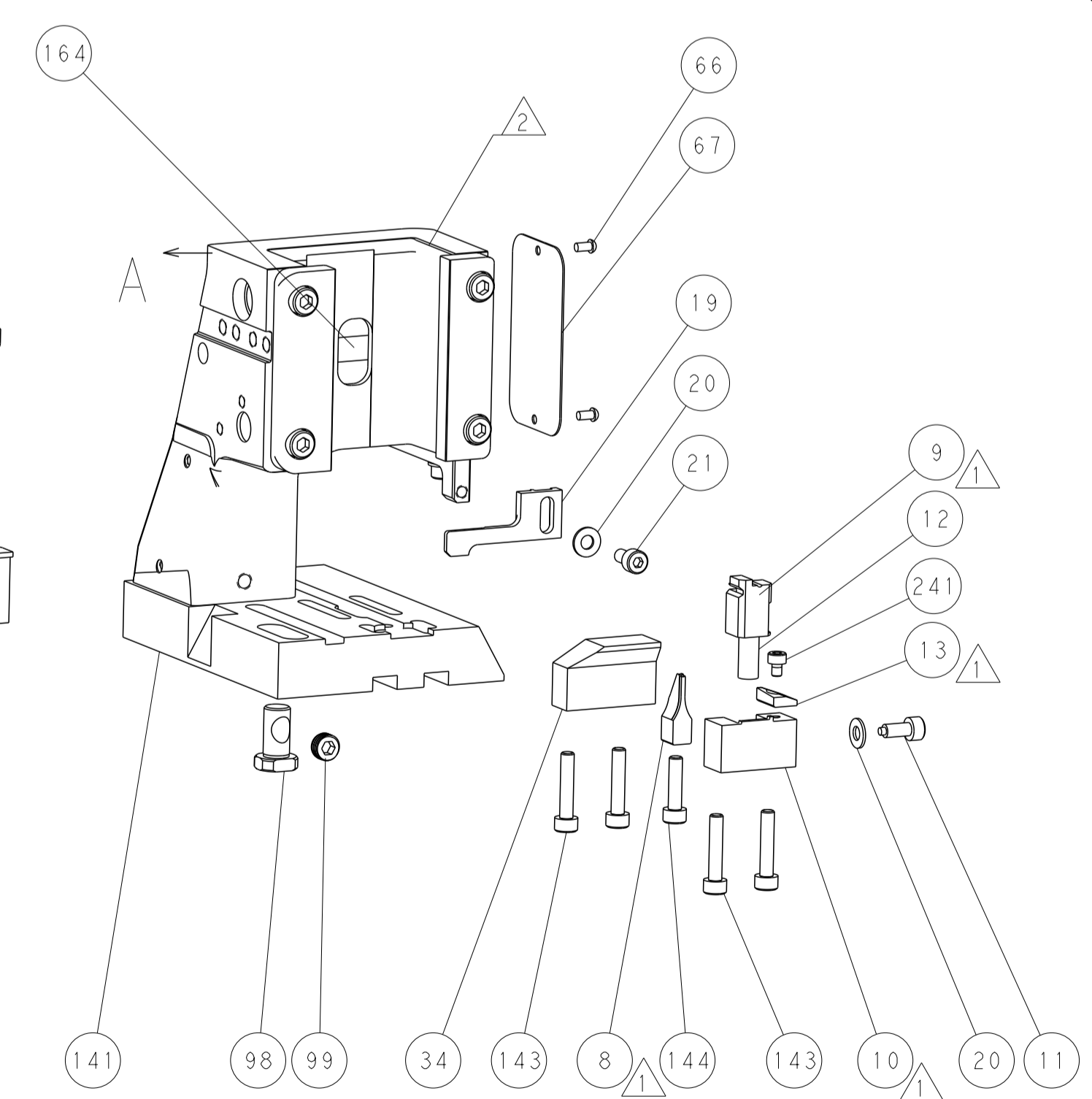
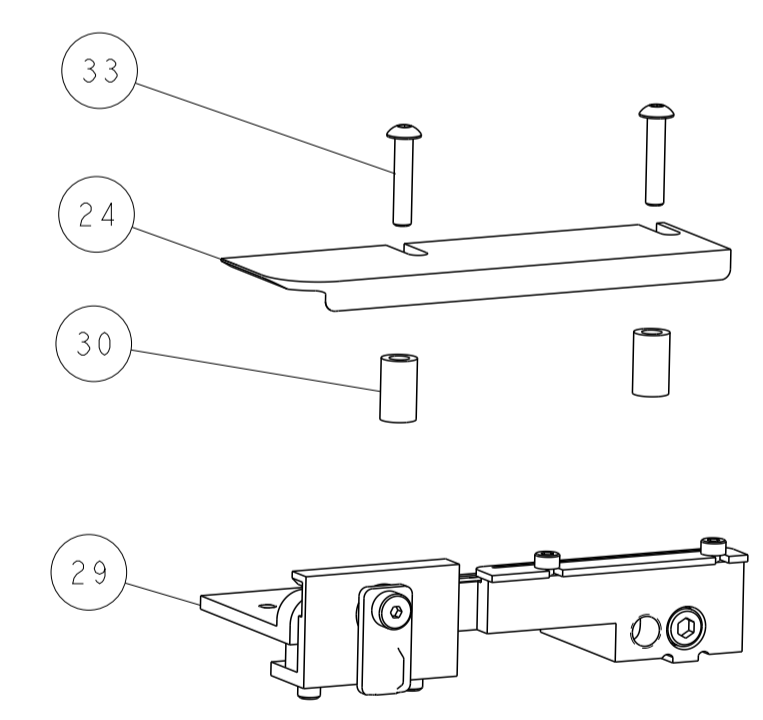
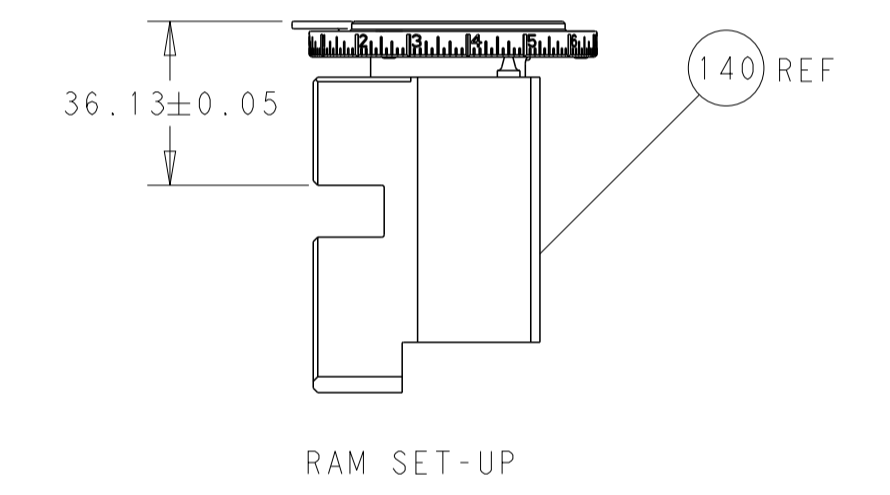
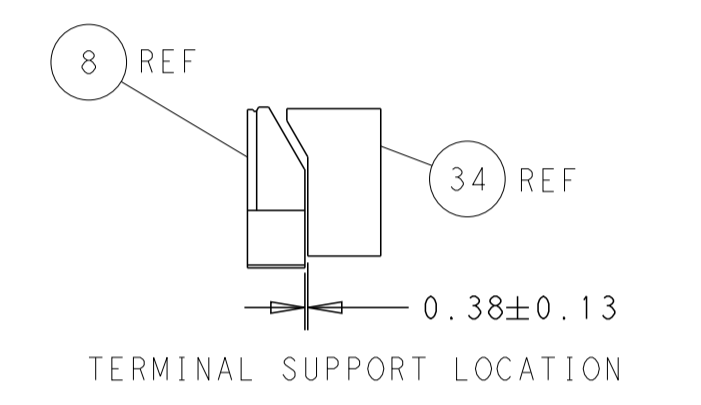
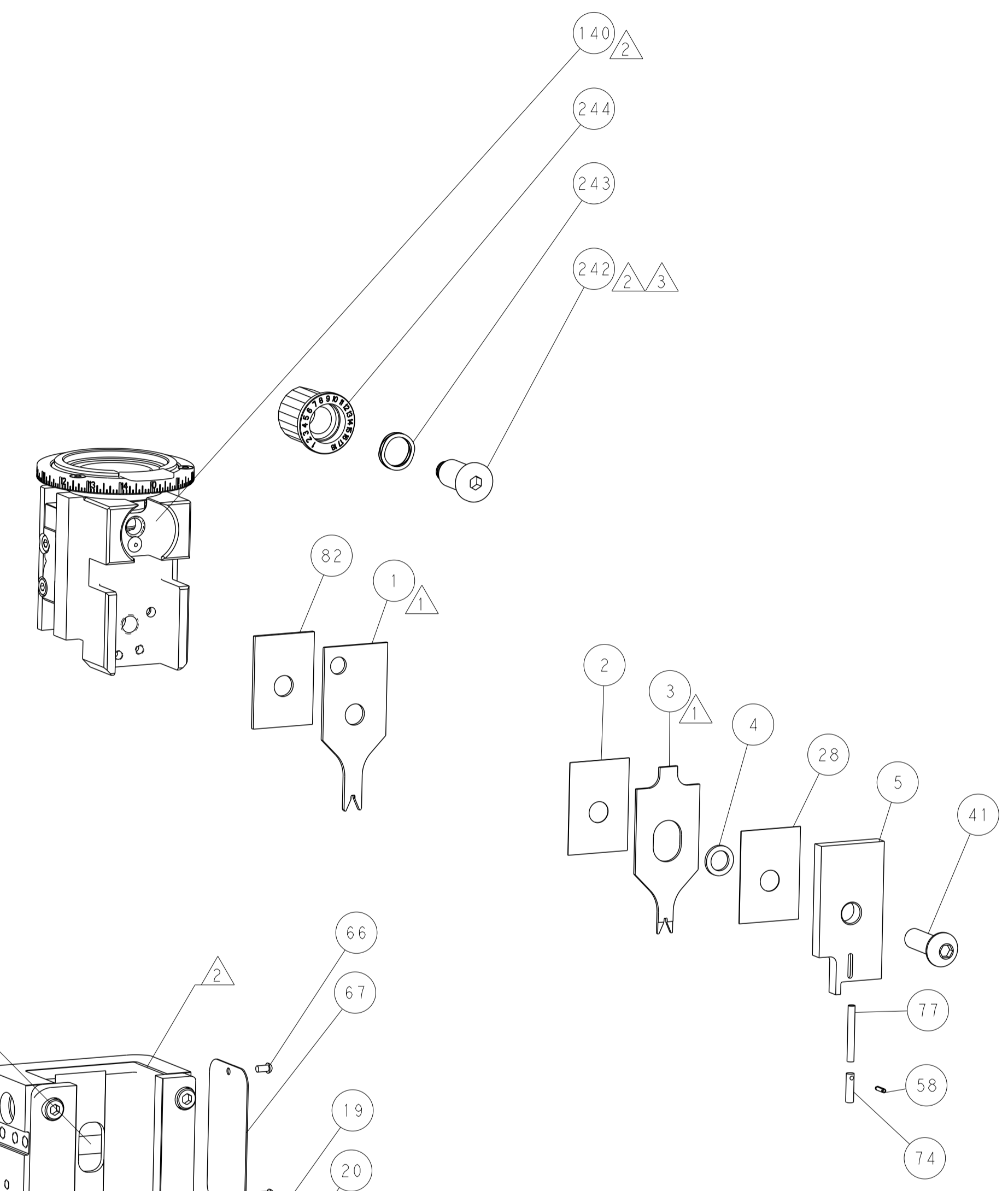
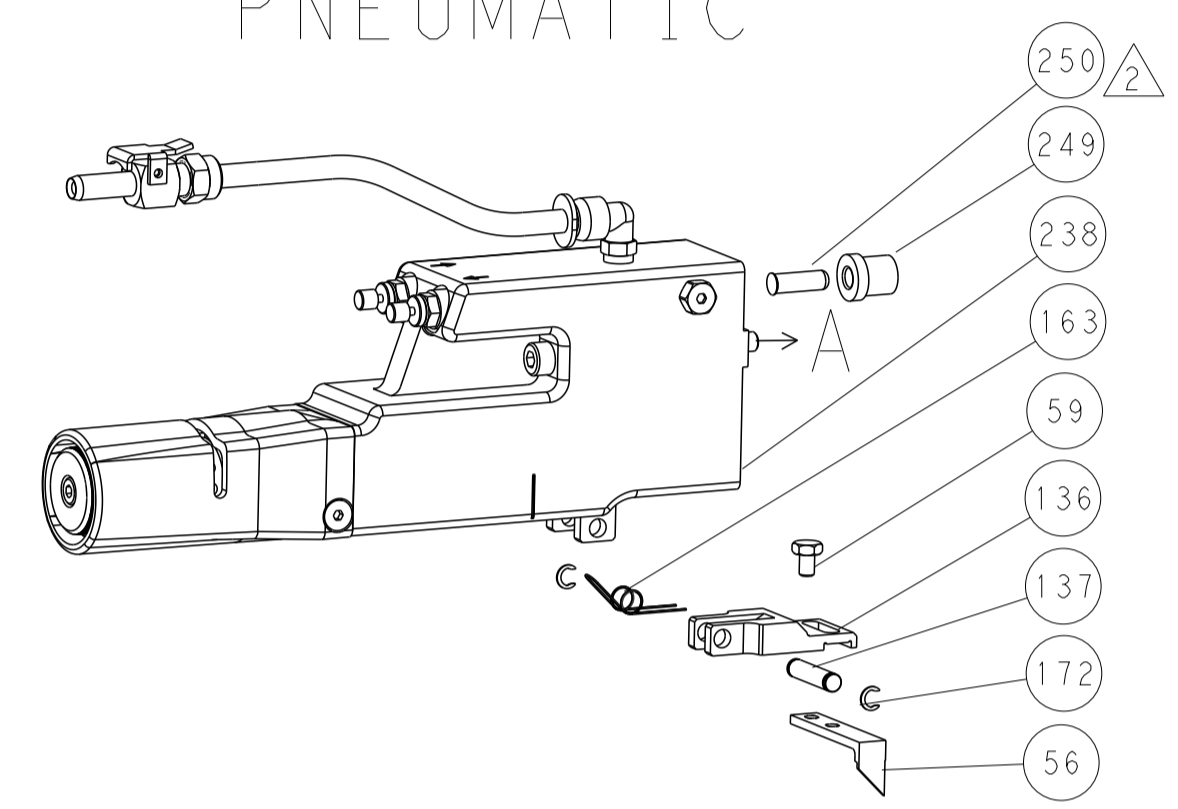

# CAM POSITIONS

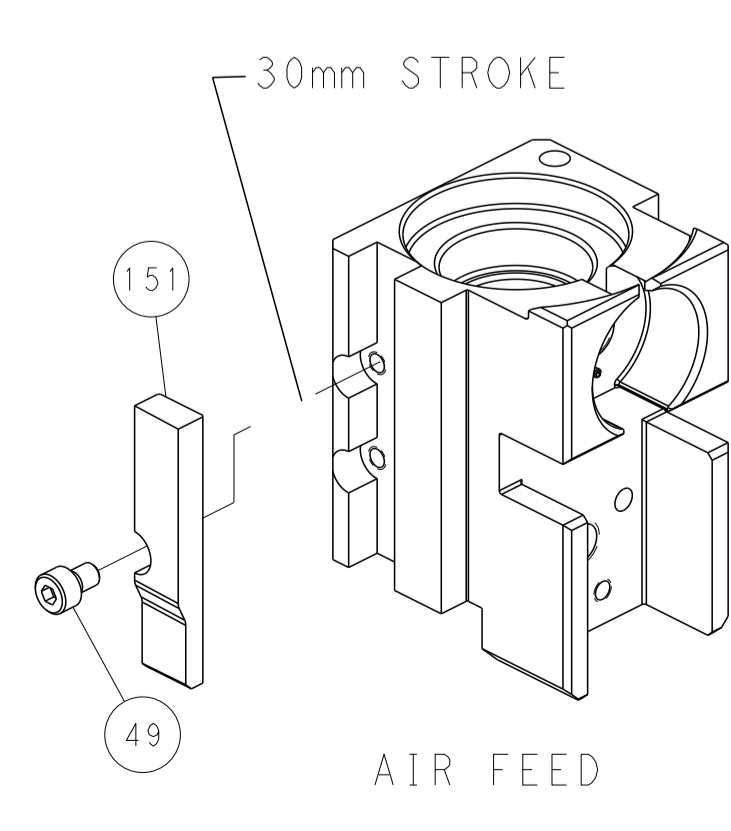
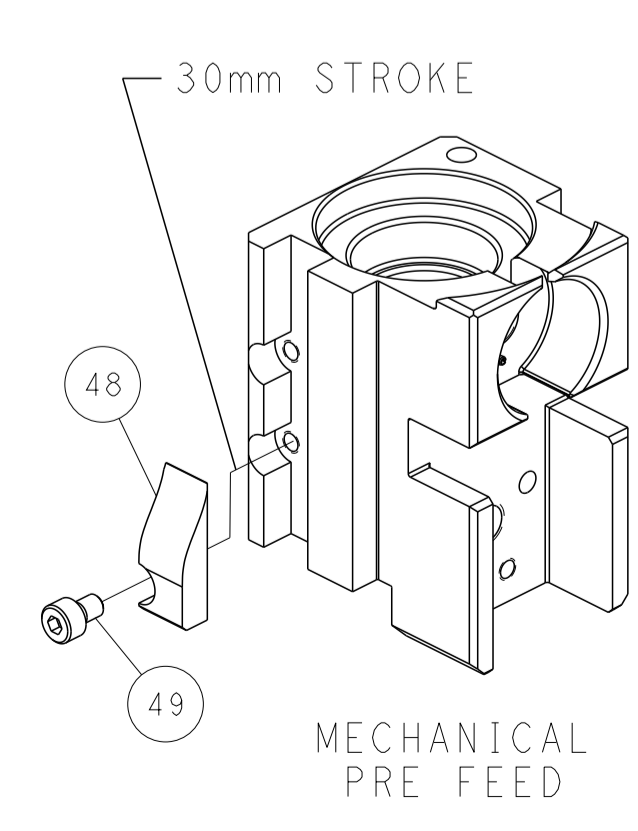
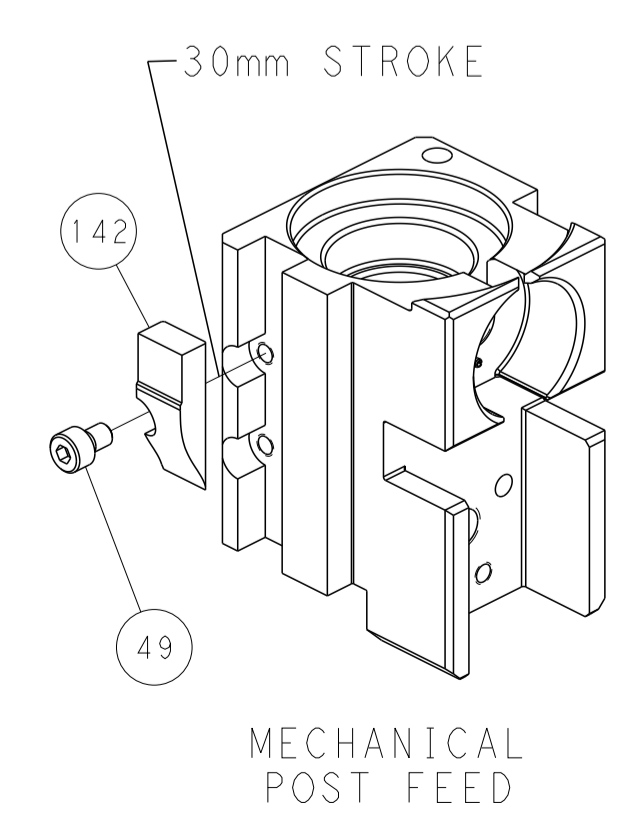

**PACIFIC VERSION**  
 Shown on sheets 3 of 4 & 4 of 4  
 (Atlantic version shown on sheets 1 of 4 & 2 of 4)

<small>THIS DRAWING IS UNPUBLISHED. RELEASED FOR PUBLICATION. IT IS THE PROPERTY OF TYCO ELECTRONICS CORPORATION. IT IS TO BE USED ONLY FOR THE PURPOSES AND IN THE QUANTITIES SPECIFIED IN THE ORDER. IT IS TO BE RETURNED TO TYCO ELECTRONICS CORPORATION IF NOT SO USED.</small>		DWN: R. KNEPPER 11-Jun-14 CHK: T. ELBIN 11-Jun-14 APVD: M. CLIFFORD 11-Jun-14 PRODUCT SPEC: APPLICATION SPEC: WEIGHT: - MATERIAL: -	NAME: Ocean Side Feed Applicator SIZE: A1 CAGE CODE: 00779 DRAWING NO: 2151629 SCALE: 1:2 SHEET: 1 of 4 REV: C	TE Connectivity Harrisburg, PA 17105-3608
DIMENSIONS: mm TOLERANCES UNLESS OTHERWISE SPECIFIED: 0 PLC ± 1 PLC ± 2 PLC ± 3 PLC ± 4 PLC ± ANGLES FINISH ±		Customer Accessible Production Drawing		