

RECOMMENDED MOUNTING PATTERN

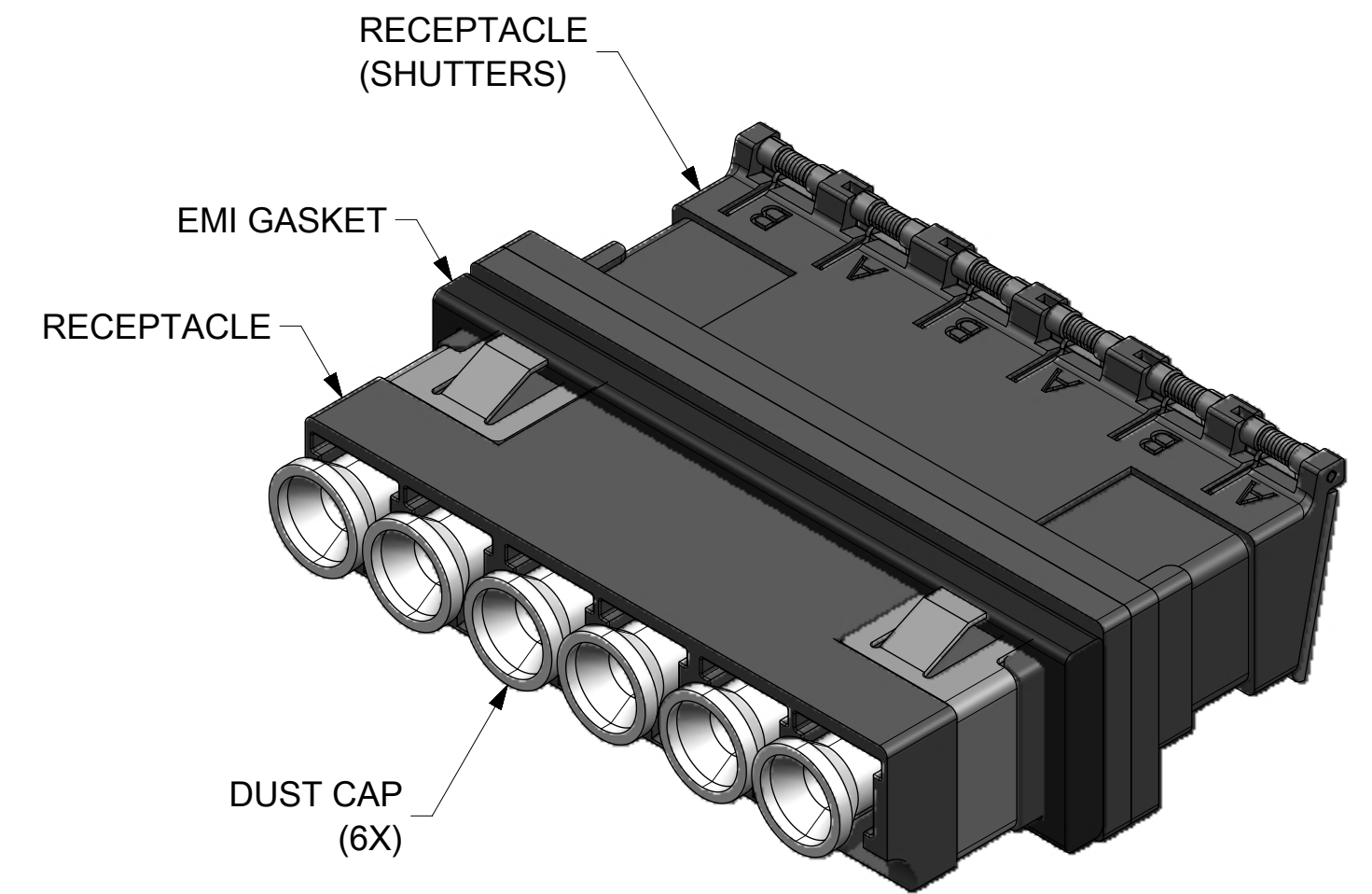
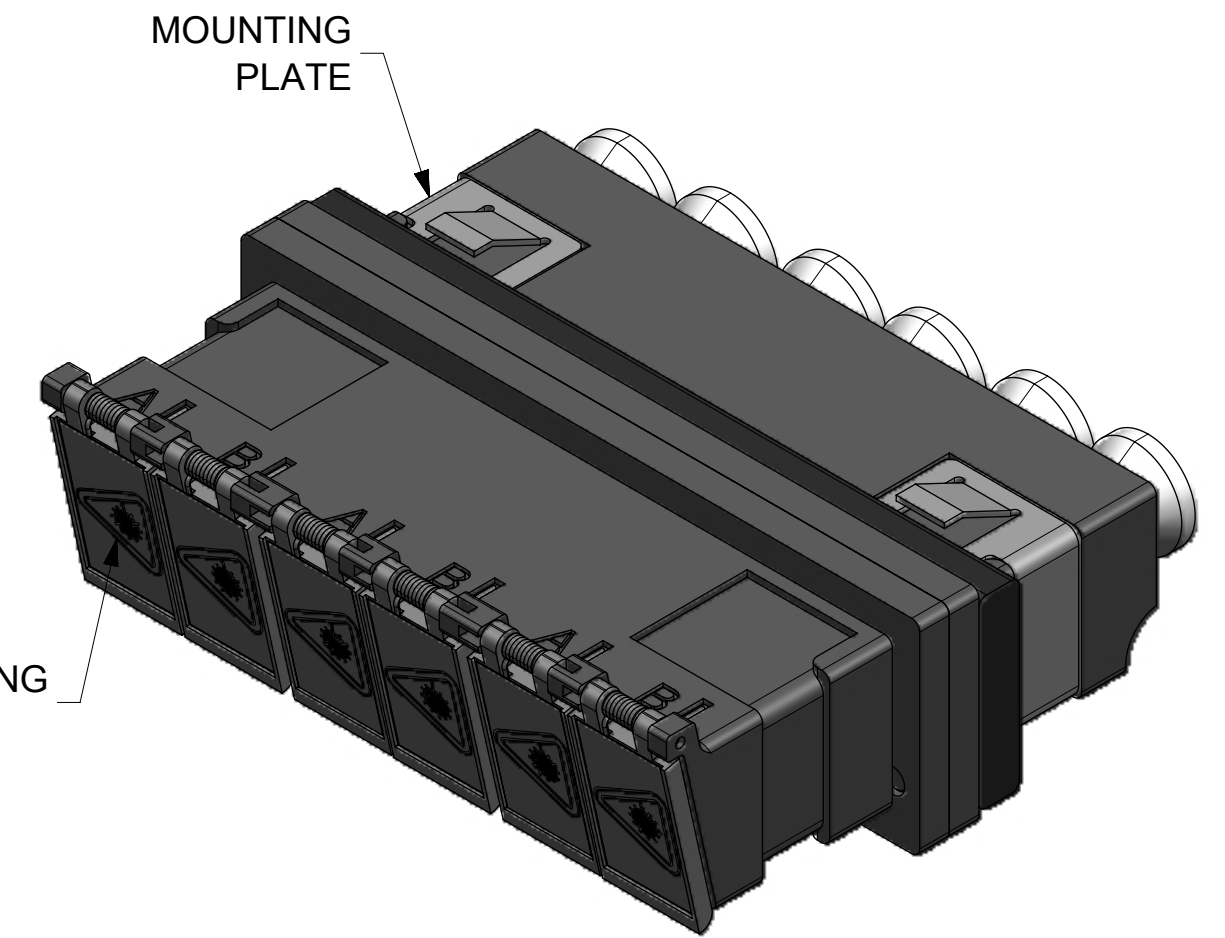
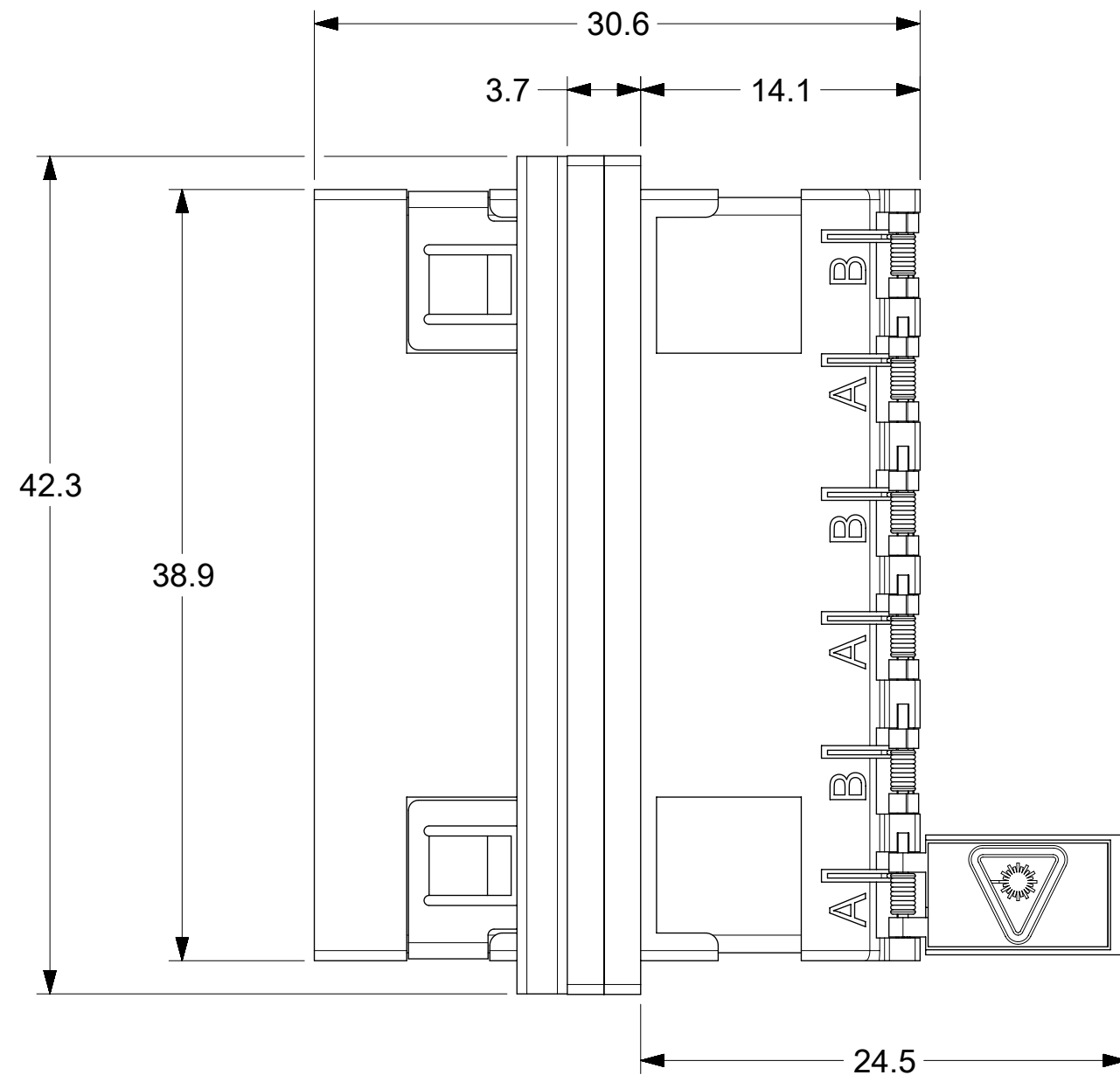
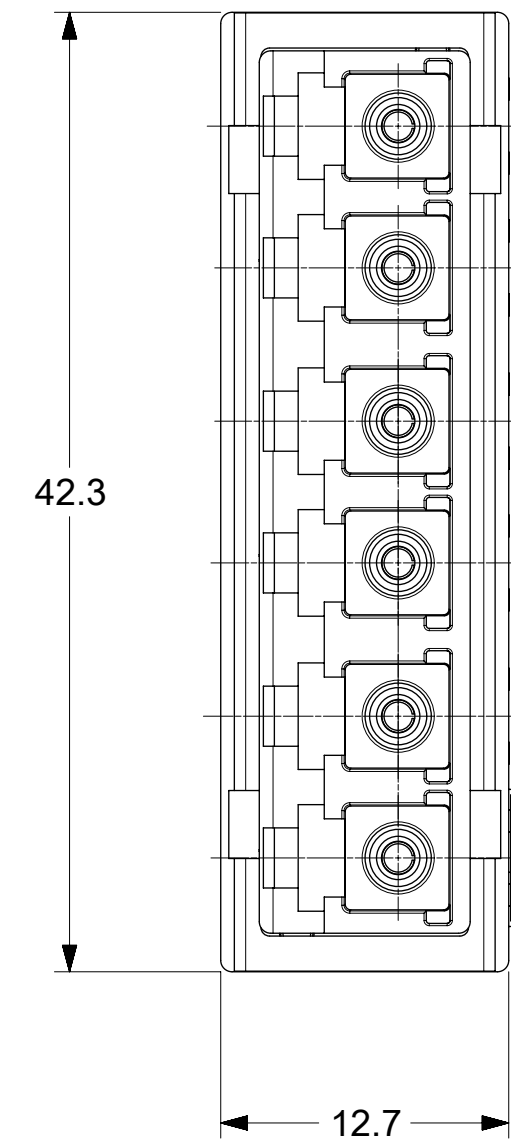
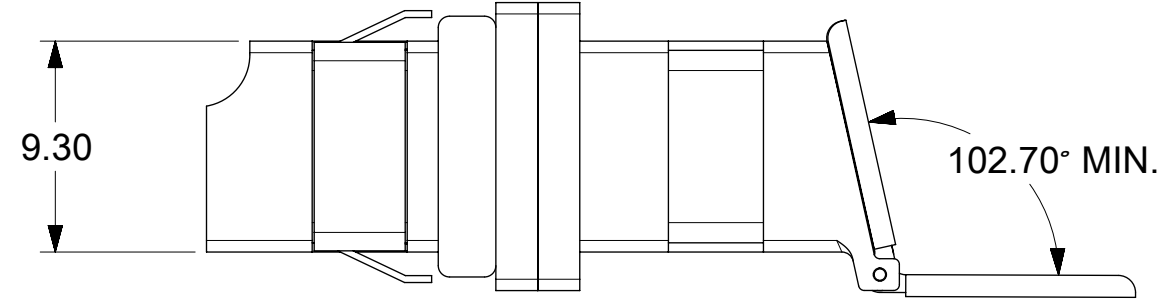

NOTES:

1. ALL DIMENSIONS ARE FOR REFERENCE ONLY.
2. DUST CAPS ARE SHOWN IN ISOMETRIC VIEWS ONLY.
3. MATERIALS:  
 RECEPTACLES - ELECTRICALLY CONDUCTIVE RESIN, BLACK  
 EMI GASKET - FABRIC-OVER FOAM  
 SHUTTERS - PEI  
 SPLIT SLEEVES - CERAMIC  
 MOUNTING PLATE - SS  
 DUST CAPS - NYLON
4. RECOMMENDED PANEL THICKNESS - 1.6 mm.

THIS DRAWING CONTAINS INFORMATION THAT IS PROPRIETARY TO MOLEX ELECTRONIC TECHNOLOGIES, LLC AND SHOULD NOT BE USED WITHOUT WRITTEN PERMISSION									
SYMBOLS	DIMENSION UNITS	SCALE	CURRENT REV DESC:						
▽ = 0	mm	3:1	EC NO: 614672 DRWN: IGUMIN 2019/03/27 CHK'D: WCHEN 2019/03/28 APPR: WCHEN 2019/03/28 INITIAL REVISION: DRWN: IGUMIN 2019/03/27 APPR: WCHEN 2019/03/28						
▽ = 0	GENERAL TOLERANCES (UNLESS SPECIFIED)								
▽ = 0	ANGULAR TOL ± °								
▽ = 0	4 PLACES ±								
▽ = 0	3 PLACES ±		PRODUCT CUSTOMER DRAWING DOCUMENT NUMBER: 1061210214 DOC TYPE: PSD DOC PART: 000 REVISION: A						
▽ = 0	2 PLACES ±								
▽ = 0	1 PLACE ±		MATERIAL NUMBER: 1061210214 CUSTOMER:						
▽ = 0	0 PLACES ±								
▽ = 0	DRAFT WHERE APPLICABLE MUST REMAIN WITHIN DIMENSIONS		THIRD ANGLE PROJECTION	DRAWING	SERIES	SHEET NUMBER		1 OF 1	
▽ = 0			⊗	C-SIZE	106121	1061210214			



LC 1X6 EMI ADAPTER, SNAP MOUNT, WITH SHUTTERS

PRODUCT CUSTOMER DRAWING

DOCUMENT NUMBER: 1061210214  
 DOC TYPE: PSD  
 DOC PART: 000  
 REVISION: A

MATERIAL NUMBER: 1061210214  
 CUSTOMER: [blank]  
 SHEET NUMBER: 1 OF 1