

Instruction manual for Evaluation Board - TB67H420FTG-

January 18th, 2018

Rev.1.1

【Outline】

The TB67H420FTG is a dual channel H-bridge driver supporting constant current PWM control system and direct PWM control system. It can control two brushed DC motors independently.

BiCD process is adopted. Rating of 50 V and 4.5 A per channel is realized.

By using Large mode, a single-channel high-current (max. 9.0 A) drive is also possible.

This evaluation board mounts necessary components to evaluate the IC. Brushed DC motor can be controlled by the constant current PWM drive and the direct PWM drive.

Please sense controllability of brushed DC motors applying the TB67H420FTG.

【Note】

In using, please be careful about thermal condition sufficiently.

As for each control signal, please refer to the IC specification by accessing to the below URL.

<http://toshiba.semicon-storage.com/eu/product/linear/motordriver/detail.TB67H420FTG.html>

Further, the application of this evaluation board is limited to the purpose of evaluating and learning the motor control. Please do not ship them to a market.

Connection to Evaluation board

Corresponding table (Silk name vs. Signal name)

(Note) Each silk name and signal name on the board is different because the boards for the series products are common.

Silk name	Signal name
39	PWMA
40	PWMB
41	INA1
42	INA2
43	INB1
44	INB2
45	NC
46	NC
47	LO1
48	LO2
AGC0	TBLKAB
AGC1	HBMODE

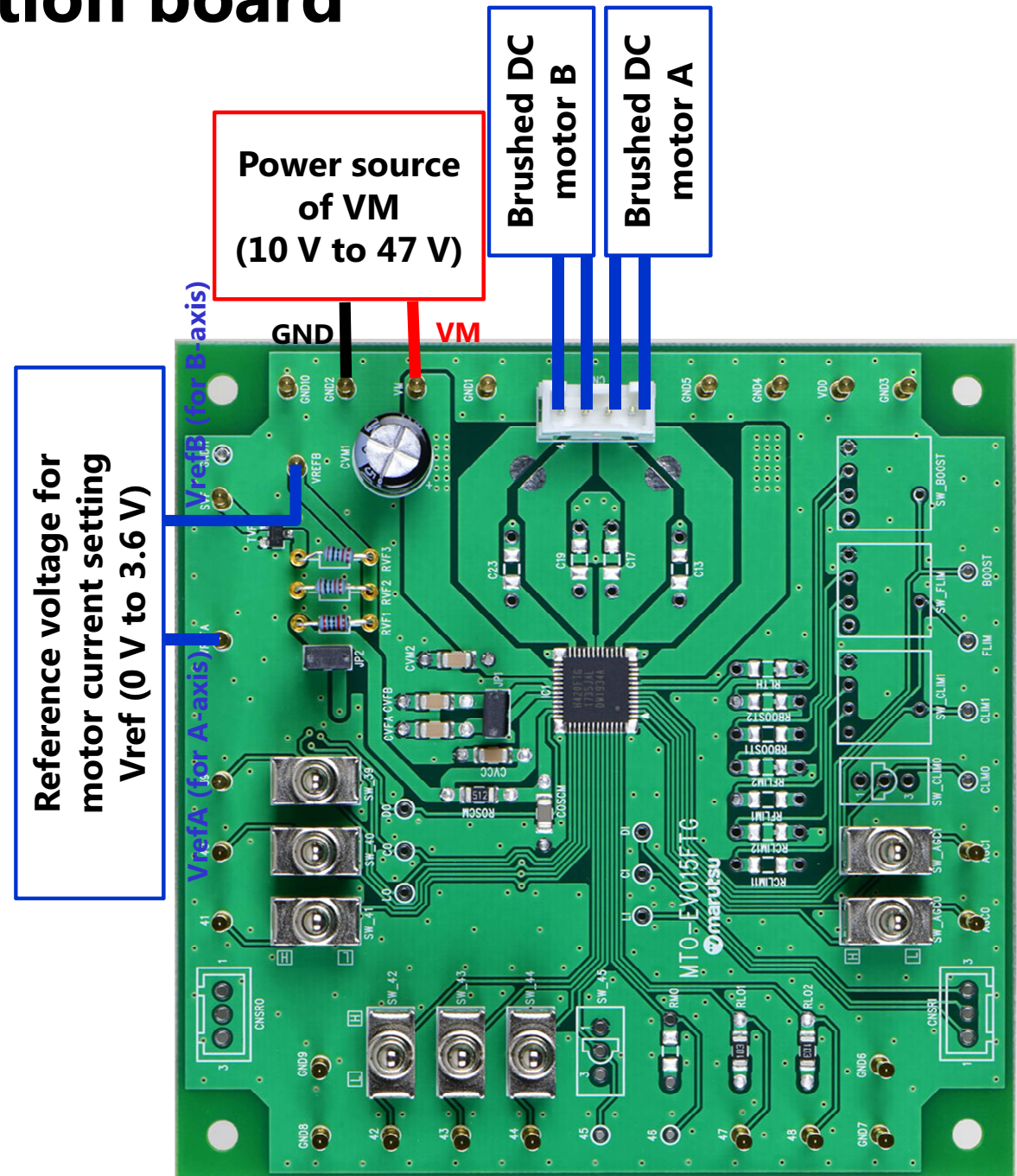

Setting evaluation board 1

Setting motor current

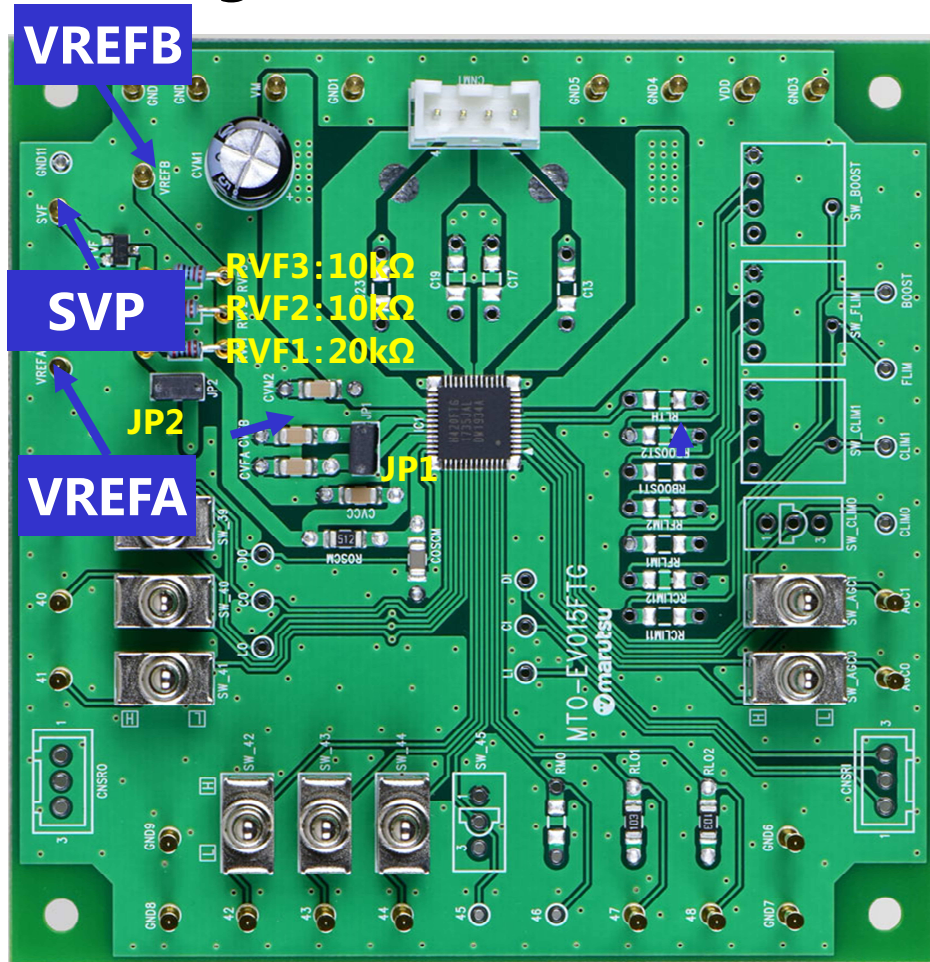

Setting motor current

$$I_{out(max)} = V_{REF(V)} \times 1.25$$

Resistors of RVF1 (20 kΩ), RVF2 (10 kΩ), and RVF3 (10kΩ) are mounted. Jumpers of JP1 and JP2 are connected.

Therefore, in the initial state, each voltage for VREFA and VREFB is supplied by dividing the VCC voltage.

When SVP pin is connected to GND, the VREF voltage is about 1.67 V. When SVP pin is connected to VCC (5 V), the VREF voltage is about 1 V.

Select the resistor between RVF1, RVF2, and RVF3 according to the usage conditions.

When supplying the external voltage to VREF, disconnect resistors (RVF1, RVF2, and RVF3). When supplying different voltage to VREFA and VREFB, disconnect the short-pin of JP1.

Waveform of motor current

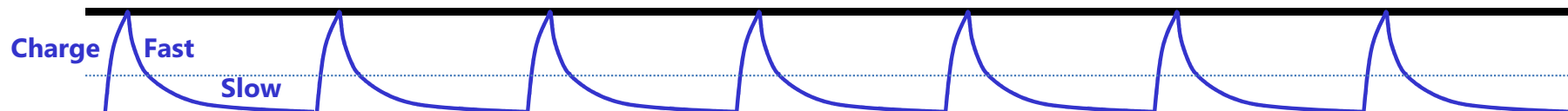

Current value of setting motor

Setting evaluation board 2

Setting chopping frequency of the constant current of the motor

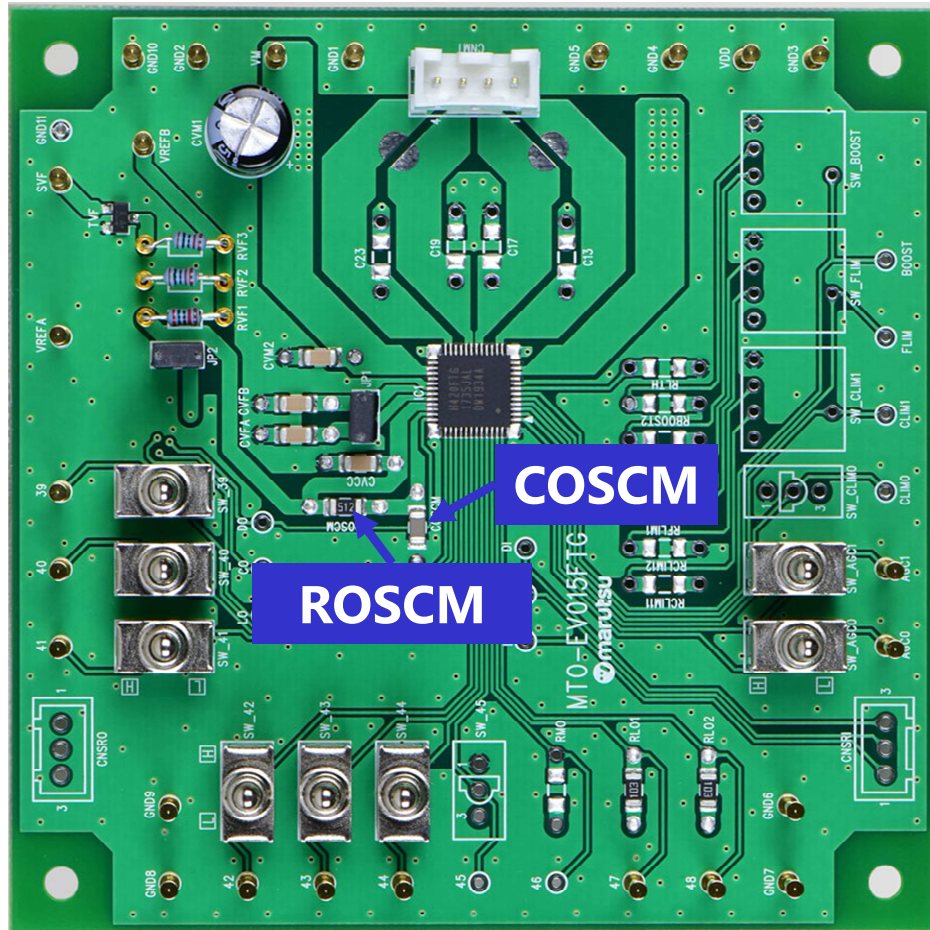

Formula of setting chopping frequency

$$f_{OSCM} \text{ [MHz]} = 4.0 \times ROSC \text{ [k}\Omega\text{]}^{(-0.8)}$$

$$f_{chop} = f_{OSCM} / 16$$

COSC = 270 pF (fix)

Mounted components are as follows;

Capacitor (OSCM=270 pF)

Resistor (ROSCM=5.1 kΩ)

Waveform of motor current

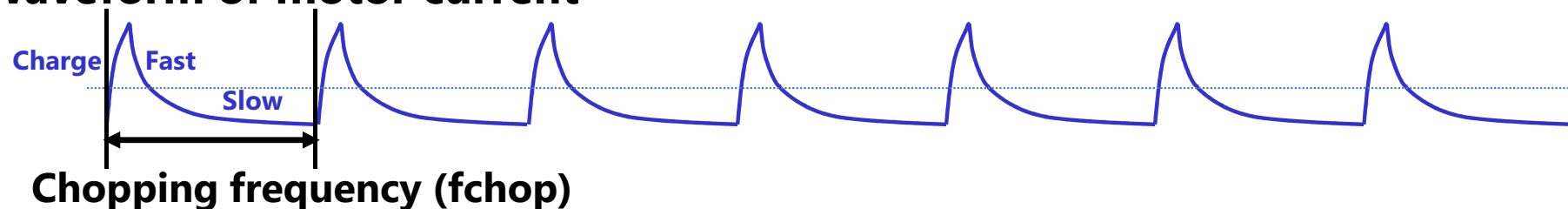

Setting evaluation board 3

Setting motor operation

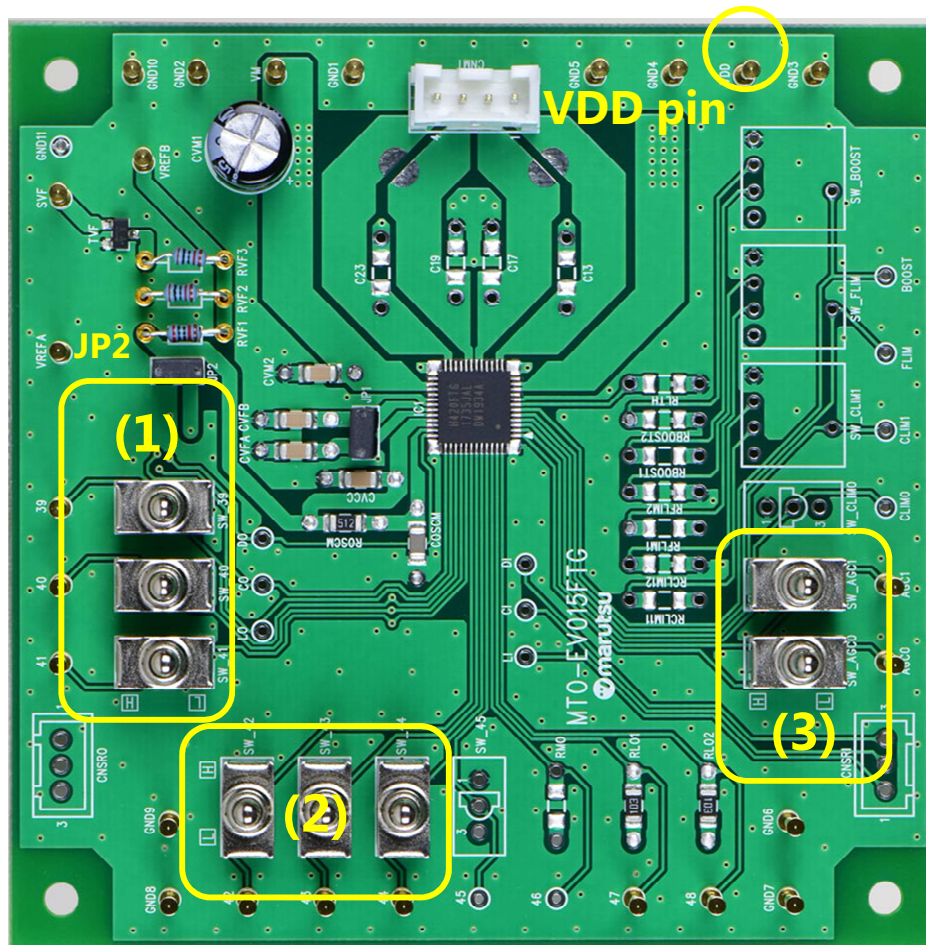

Three-position toggle switches ((1), (2), and (3) in the left diagram) for setting the operation of the TB67H420FTG are mounted.

In using these switches, short-circuit the jumper of JP2 (i.e. initialize) or supply 5-V voltage from the VDD pin.

【Switches of (1) and (3)】

Tilting rightward: Low level

Tilting leftward: High level

Middle position Neutral. The input signal from the pins is valid.

【Switch of (2)】

Tilting downward: Low level

Tilting upward: High level

Middle position: Neutral. The input signal from the pins is valid.

※Refer to the datasheet for information on how to use and set each function.

How to treatment evaluation board in using Large Mode

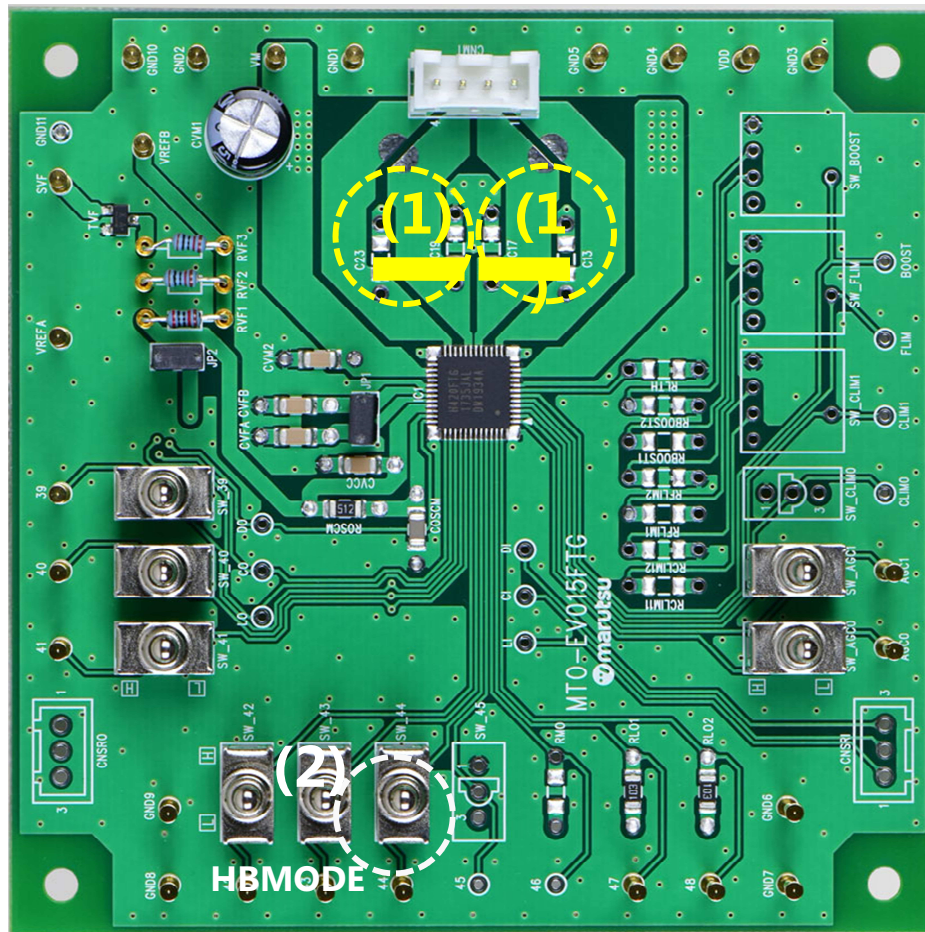

- (1) Short-circuit output lines.
Pins of OUTA+ and OUTA-, and pins of OUTB- and OUTB+ should be connected respectively. Short-circuit them by using round plates for C13, C17, C19, and C23.
- (2) Set HBMODE pin High level.
Tilt the switch to high side to input high level.

【Pin functions in Large Mode】

In Large Mode, each pin function is as follows;

Silk name	Signal name
31	VREF
32	VREF
39	PWMA
40	NC
41	INA1
42	INA2
43	NC
44	NC
45	NC
46	NC
47	LO1
48	LO2
AGC0	TBLKAB
AGC1	HBMODE

【Setting motor current】

Motor current in Large Mode is calculated from below formula.

$$I_{out(max)} = VREF(V) \times 2.5$$

Circuit of evaluation board

