

# Assembly Instructions

Connector Part Number	Stripping Tool Part Number	Crimp Tool Part Number	Hex Size	
			Pin	Ferrule
VN10-2087	N/A	DCC1113	Solder	5.41

1) Slide the ferrule onto the cable. Strip the cable to the dimensions shown. Take care not to nick the centre conductor or braid.

- A = 9.5mm
- B = 4mm
- C = 4mm

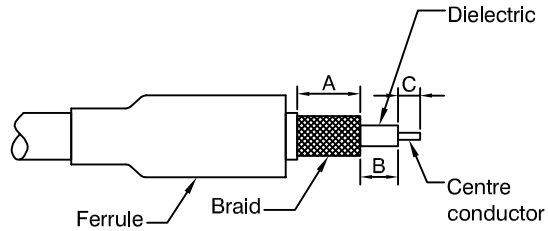

3) Insert the contact into the body and ensure that the contact captivates. Make sure that the braid is on the outside of the mandrel. Slide the ferrule over the braid until the ferrule butts up against the body. Crimp the ferrule using the correct tool for the connector.

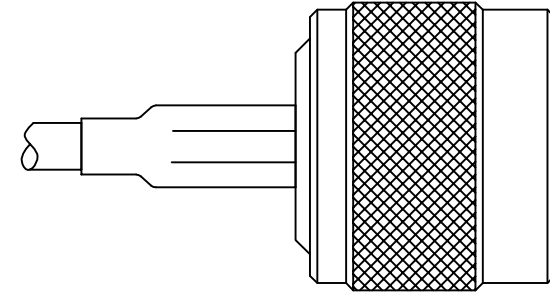

2) Slide the insulators over the dielectric. Crimp the contact onto the centre conductor.

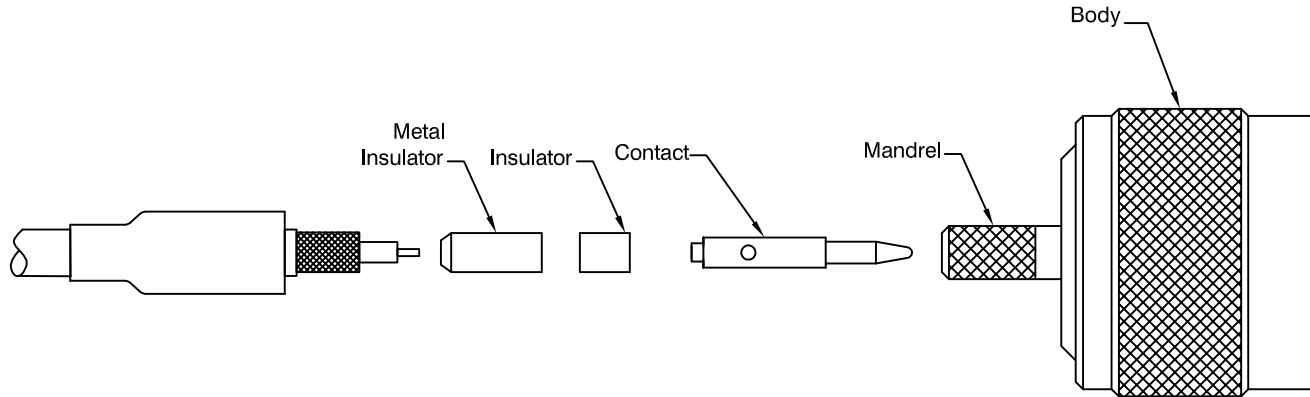

First Issue	SN	1	06 Jan 03
DESCRIPTION OF REVISION	APPVD	ISS	DATE



Cinch Connectivity Solutions, Ltd  
 11 Bilton Road  
 Chelmsford  
 Essex CM1 2UP, England  
 T: +44 (0) 1245 342060  
 F: +44 124 535 8938

SCALE: Not To Scale

DIMENSIONS: mm

TOLERANCES:  
 ± 0.2mm unless  
 otherwise stated

DRAWN BY:

S Nash

CHECKED BY:

P Couzens

APPROVED BY:

P Couzens

DATE:

06 Jan 03

TITLE:

Stripping and Assembly  
 Instructions for N crimp  
 Plug.

PART NUMBER:

**VAIN1104**

PAGE: 1 of 1