

# CMPA0060002D

2 W, 0.2 - 6.0 GHz, GaN HEMT MMIC  
Power Amplifier

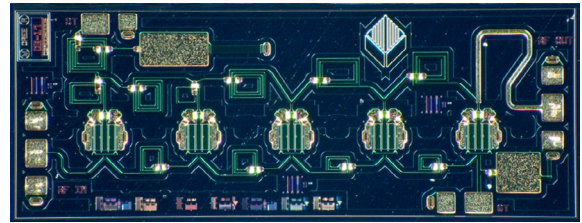

PN: CMPA0060025D

## Description

WolfSpeed's CMPA0060002D is a gallium nitride (GaN) High Electron Mobility Transistor (HEMT) based monolithic microwave integrated circuit (MMIC). GaN has superior properties compared to silicon or gallium arsenide, including higher breakdown voltage, higher saturated electron drift velocity and higher thermal conductivity. GaN HEMTs also offer greater power density and wider bandwidths compared to Si and GaAs transistors. This MMIC employs a distributed (traveling-wave) amplifier design approach, enabling extremely wide bandwidths to be achieved in a small footprint.

## Typical Performance Over 0.5 - 6.0 GHz ( $T_c = 25^\circ\text{C}$ )

Parameter	0.5 GHz	1.0 GHz	2.5 GHz	4.0 GHz	6.0 GHz	Units
Gain	18.7	17.4	17.6	17.4	17.6	dB
Saturated Output Power @ $P_{IN}$ 23 dBm	7.0	6.3	5.7	4.3	3.6	W
Power Gain @ $P_{IN}$ 23 dBm	15.4	15.0	14.5	13.3	12.5	dB
PAE @ $P_{IN}$ 23 dBm	43	40	36	28	31	%

Note:  $V_{DD} = 28\text{ V}$ ,  $I_b = 100\text{ mA}$

### Features

- 17 dB Small Signal Gain
- 2 W Typical  $P_{SAT}$
- Operation up to 28 V
- High Breakdown Voltage
- High Temperature Operation
- Size 0.169 x 0.066 x 0.004 inches

### Applications

- Ultra Broadband Amplifiers
- Fiber Drivers
- Test Instrumentation
- EMC Amplifier Drivers



### Absolute Maximum Ratings (not simultaneous) at 25°C Case Temperature

Parameter	Symbol	Rating	Units
Drain-Source Voltage	$V_{DSS}$	84	$V_{DC}$
Gate-to-Source Voltage	$V_{GS}$	-10, +2	
Storage Temperature	$T_{STG}$	-65, +150	°C
Operating Junction Temperature	$T_J$	225	
Maximum Forward Gate Current	$I_{GMAX}$	2	mA
Thermal Resistance, Junction to Case (packaged) <sup>1</sup>	$R_{\theta JC}$	4.0	°C/W

Note:

<sup>1</sup> Eutectic die attach using 80/20 AuSn mounted to a 40 mil thick CuW carrier

### Electrical Characteristics (Frequency = 20 MHz to 6,000 MHz unless otherwise stated; $T_c = 25^\circ\text{C}$ )

Characteristics	Symbol	Min.	Typ.	Max.	Units	Conditions
<b>DC Characteristics</b>						
Gate Threshold Voltage <sup>1</sup>	$V_{GS(th)}$	-3.8	-3.0	-2.7	V	$V_{DS} = 20\text{ V}, \Delta I_D = 2\text{ mA}$
Gate Quiescent Voltage	$V_{GS(Q)}$	—	-2.7	—	$V_{DC}$	$V_{DD} = 26\text{ V}, I_{DQ} = 100\text{ mA}$
Saturated Drain Current <sup>2</sup>	$I_{DS}$	—	1.94	—	A	$V_{DS} = 6.0\text{ V}, V_{GS} = 2.0\text{ V}$
<b>RF Characteristics<sup>5</sup></b>						
Small Signal Gain <sup>3</sup>	S21	13.5	18	—	dB	$V_{DD} = 26\text{ V}, I_{DQ} = 100\text{ mA}$
Input Return Loss	S11	—	9	—		
Output Return Loss	S22	—	11	—		
Output Power <sup>4</sup>	$P_{OUT}$	2	4	—	W	$V_{DD} = 26\text{ V}, I_{DQ} = 100\text{ mA}, P_{IN} = 23\text{ dBm}$
Power Added Efficiency	PAE	—	30	—	%	
Power Gain	$G_p$	—	13.0	—	dB	
Output Mismatch Stress	VSWR	—	—	5:1	$\Psi$	No damage at all phase angles, $V_{DD} = 26\text{ V}, I_{DQ} = 100\text{ mA}, P_{IN} = 23\text{ dBm}$

Notes:

<sup>1</sup> The device will draw approximately 20-25 mA at pinch off due to the internal circuit structure

<sup>2</sup> Scaled from PCM data

<sup>3</sup> The lowest test frequency is 1.0 GHz due to the lack of a low frequency termination

<sup>4</sup> Test frequencies 1.0, 2.5, and 4.0 GHz

<sup>5</sup> All data pulsed with Pulse Width = 10µsec, Duty Cycle = 0.1%



**Die Dimensions (units in microns)**

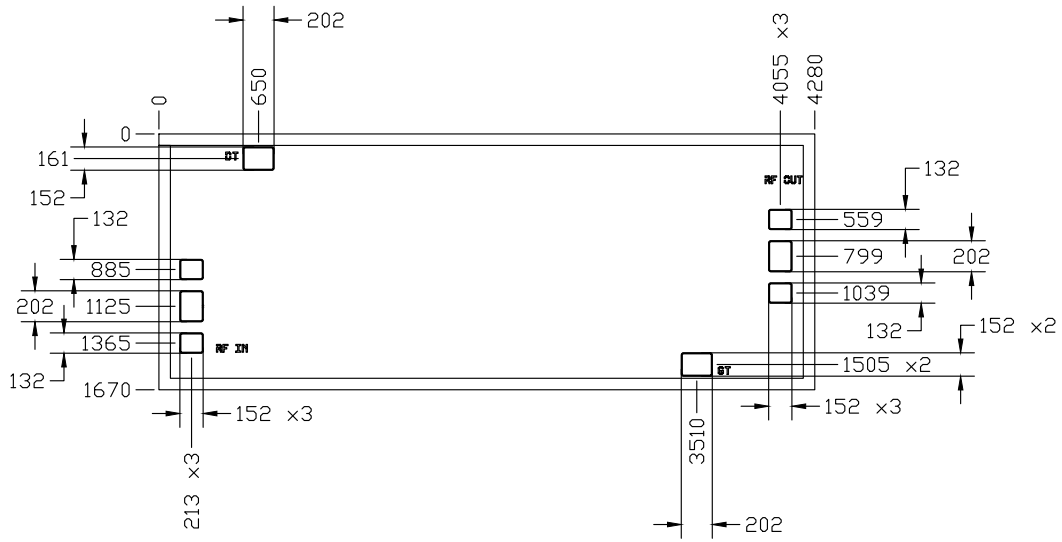

Overall die size 4280 x 1670 (+0/- 50) microns, die thickness 100 (+/- 10) microns.  
 All Gate and Drain pads must be wire bonded for electrical connection.

Pad Number	Function	Description	Pad Size (microns)
1	RF IN <sup>1</sup>	RF-Input pad. Matched to 50 ohm. Requires gate control from an external bias -T from -2.3 V to -3.8 V	202 x 152
2	Gate Termination	Off Chip termination for the Gate. It needs to be DC-blocked	
3	Drain Termination	Off Chip termination for the Drain. It needs to be DC-blocked	
4	RF OUT <sup>1</sup>	RF-Output pad. Matched to 50 ohm. Requires Drain supply from an external bias -T up to 26 V , 800 mA	

Note: The RF In and Out pads have a ground-signal-ground configuration with a pitch of 1 mil (25 um)

**Die Assembly Notes**

- Recommended solder is AuSn (80/20) solder. Refer to Wolfspeed’s website for the Eutectic Die Bond Procedure application note at [www.wolfspeed.com/rf/document-library](http://www.wolfspeed.com/rf/document-library)
- Vacuum collet is the preferred method of pick-up
- The backside of the die is the Source (ground) contact
- Die back side gold plating is 5 microns thick minimum
- Thermosonic ball or wedge bonding are the preferred connection methods
- Gold wire must be used for connections
- Use the die label (XX-YY) for correct orientation



### Functional Block Diagram

This device employs a wideband, traveling wave amplifier topology. It has an internal termination for both the Drain and the Gate, which works well over 2.5-6.0 GHz. For operation below 2.5 GHz an external termination is required. This termination needs to be DC-blocked and suitable to withstand up to 3 W of RF power. (Refer to the reference design section for the LF-termination in this datasheet for more details). The circuits also require external wideband Bias -T's to supply voltage to the Gate and Drain. The Bias-T at the Drain needs to be designed to handle 28 V and up to 800 mA.

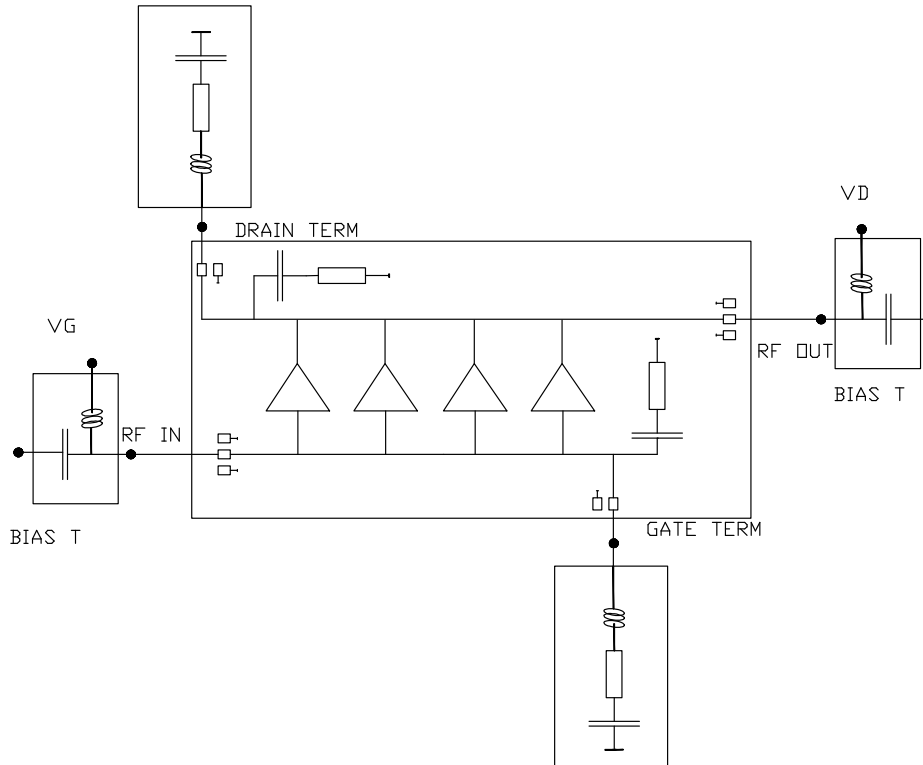

### Electrostatic Discharge (ESD) Classifications

Parameter	Symbol	Class	Classification Level	Test Methodology
Human Body Model	HBM	TBD	ANSI/ESDA/JEDEC JS-001 Table 3	JEDEC JESD22 A114-D



### External Termination Reference Design

The following is a plot of the gain of the die only.

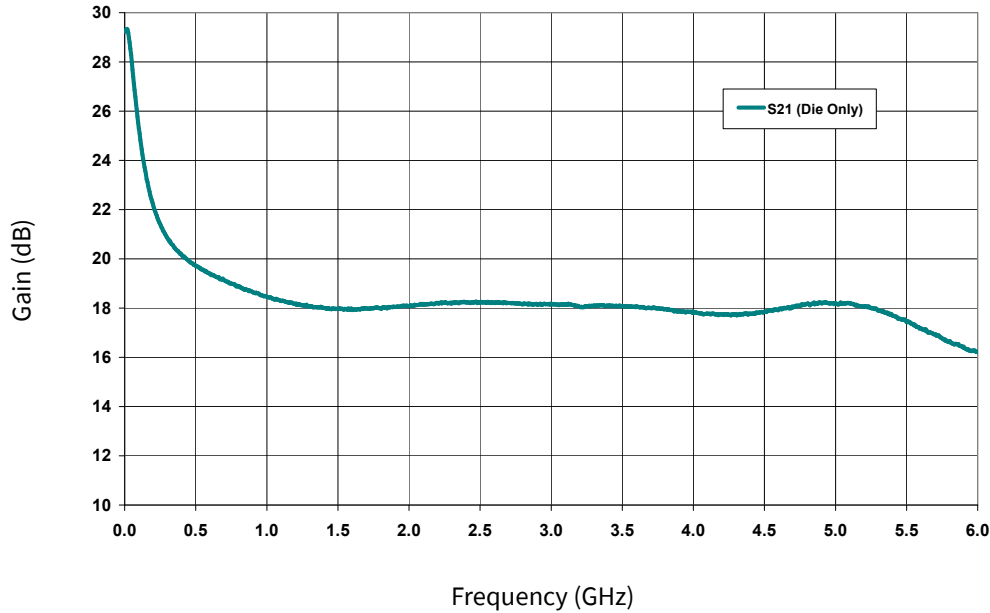

Notes:

- <sup>1</sup> An off chip termination is needed to reduce the high gain peak at low frequencies
- <sup>2</sup> The off chip termination should be designed to minimize the impact on the MMIC's performance at higher frequencies

### LRC Reference Circuit

The Drain and Gate circuit use the same L and C components but different values for the resistor.

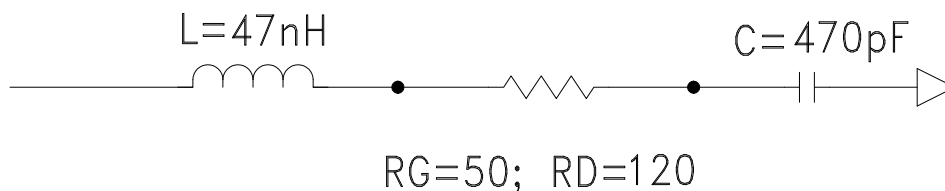

The Drain resistor needs to be dimensioned to handle 3 W of RF dissipation for the lowest frequencies while the Gate resistor needs to handle 0.5 W. The suppliers of the SMT components are:

- L1 = 47nH, CoilCraft PN: 0402CS-47NXJB
- C1 = 470pf Murata PN: GRM1885C2A471A01D



Typical Performance

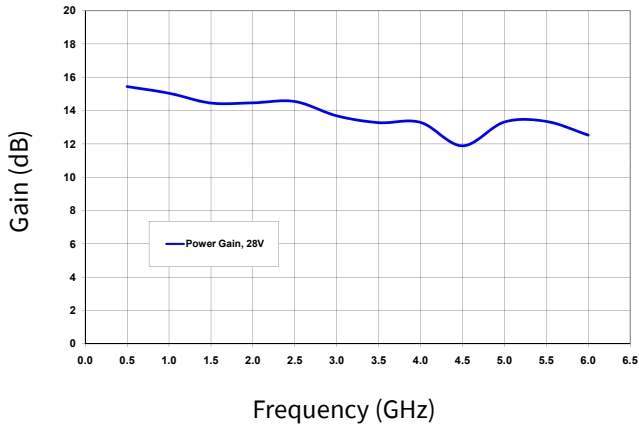

**Figure 1.** Power Gain vs Frequency  
 $V_{DD} = 28\text{ V}$ ,  $P_{IN} = 23\text{ dBm}$

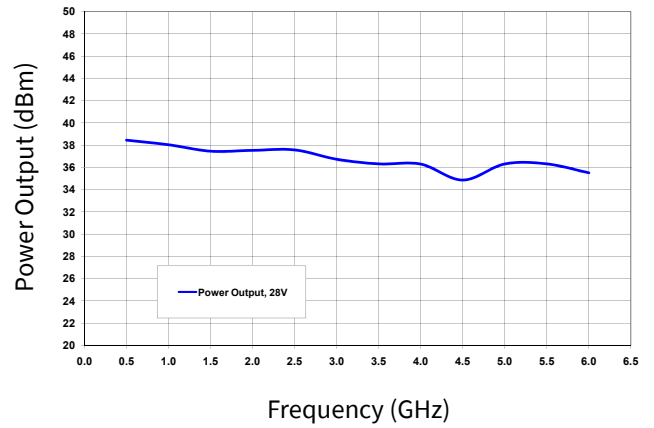

**Figure 2.** Power Output vs Frequency  
 $V_{DD} = 28\text{ V}$ ,  $P_{IN} = 23\text{ dBm}$

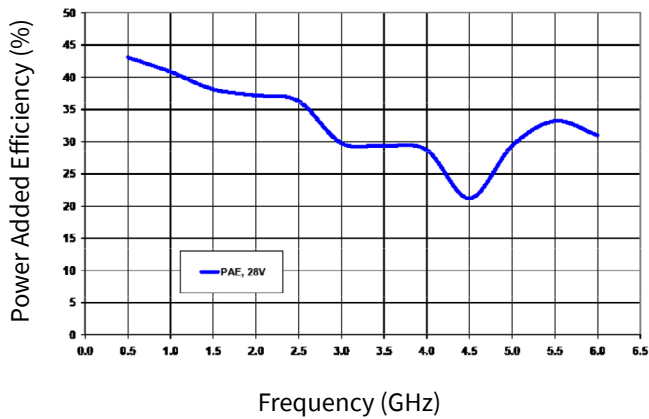

**Figure 3.** Power Added Efficiency vs Frequency  
 $V_{DD} = 28\text{ V}$ ,  $P_{IN} = 23\text{ dBm}$

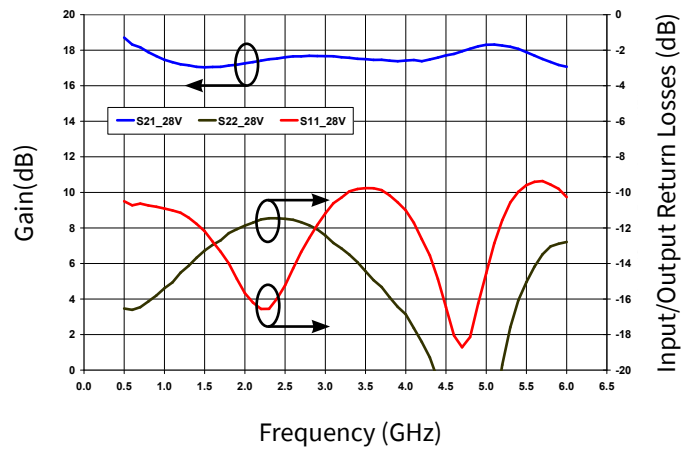

**Figure 4.** Gain and Return Losses vs Frequency  
 $V_{DD} = 28\text{ V}$ ,  $I_{DQ} = 100\text{ mA}$



**Product Ordering Information**

Order Number	Description	Unit of Measure	Image
CPMA0060002D	GaN MMIC Power Amplifier Bare Die	Each	

**For more information, please contact:**

4600 Silicon Drive  
Durham, NC 27703 USA  
Tel: +1.919.313.5300  
[www.wolfspeed.com/RF](http://www.wolfspeed.com/RF)

Sales Contact  
[RFSales@wolfspeed.com](mailto:RFSales@wolfspeed.com)

RF Product Marketing Contact  
[RFMarketing@wolfspeed.com](mailto:RFMarketing@wolfspeed.com)

## Notes & Disclaimer

---

Specifications are subject to change without notice. “Typical” parameters are the average values expected by Wolfspeed in large quantities and are provided for information purposes only. Wolfspeed products are not warranted or authorized for use as critical components in medical, life-saving, or life-sustaining applications, or other applications where a failure would reasonably be expected to cause severe personal injury or death. No responsibility is assumed by Wolfspeed for any infringement of patents or other rights of third parties which may result from use of the information contained herein. No license is granted by implication or otherwise under any patent or patent rights of Wolfspeed.

©2009-2022 Wolfspeed, Inc. All rights reserved. Wolfspeed® and the Wolfstreak logo are registered trademarks and the Wolfspeed logo is a trademark of Wolfspeed, Inc.  
PATENT: <https://www.wolfspeed.com/legal/patents>

*The information in this document is subject to change without notice.*