

*i*MOTION™

DPAK IGBT Motor Drive Reference Design Kit

Description

The reference design power board is designed to showcase IR DPAK IRGR4610DPBF IGBT in a motor drive application.

Product Summary

- IGBT inverter power stage for 3 phase motors
- FR4 based 1oz copper two-layer PCB
- 100-240V AC input range
- 300W motor power range (with heatsink)
- Single shunt configuration

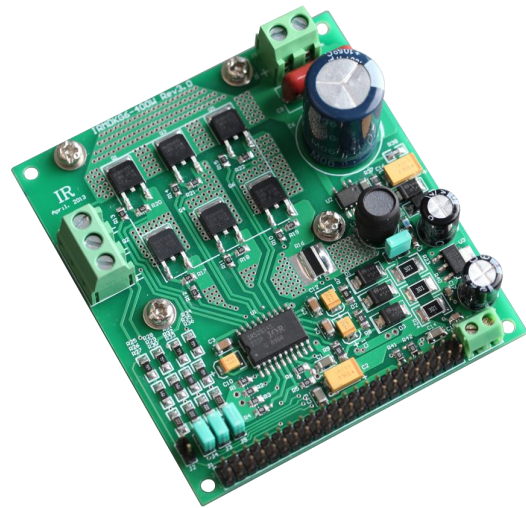

The 76 x 83mm board has two layers with 1oz (~35µm) copper each.

IRGR4610DPBF Features

Features	→	Benefits
Low $V_{CE(ON)}$ and switching losses		High efficiency in a wide range of applications and switching frequencies
Square RBSOA and maximum junction temperature of 175°C		Improved reliability due to rugged hard switching performance and high power capability
Positive $V_{CE(ON)}$ temperature coefficient and tight distribution of parameters		Excellent current sharing in parallel operation
5µs short circuit SOA		Enables short circuit protection scheme
Lead-free, RoHS compliant		Environmentally friendly

Safety Precautions

In addition to the precautions listed throughout this manual, please read and understand the following statements regarding hazards associated with development system.



ATTENTION: The **ground potential** of the IRMDKG6-300W system is biased to a negative DC bus voltage potential. When measuring voltage waveform by oscilloscope, the scope ground needs to be isolated. Failure to do so may result in personal injury or death. Darkened display LEDs is not an indication that capacitors have discharged to safe voltage levels.



ATTENTION: IRMDKG6-300W system contains dc bus capacitors which take time to discharge after removal of the main supply. Before working on the drive system, wait at least three minutes and until the capacitors have discharged to safe voltage levels. Failure to do so may result in personal injury or death. Darkened display LEDs is not an indication that capacitors have discharged to safe voltage levels.



ATTENTION: Only personnel familiar with the drive and associated machinery should plan or implement the installation, start-up, and subsequent maintenance of the system. Failure to comply may result in personal injury and/or equipment damage.



ATTENTION: The surface temperatures of the drive may become hot, which may cause injury.



ATTENTION: IRMDKG6-300W system contains ESD (Electrostatic Discharge) sensitive parts and assemblies. Static control precautions are required when installing, testing, servicing or repairing this assembly. Component damage may result if ESD control procedures are not followed. If you are not familiar with static control procedures, reference applicable ESD protection handbook and guideline.



ATTENTION: An incorrectly applied or installed drive can result in component damage or reduction in product life. Wiring or application errors such as undersizing the motor, supplying an incorrect or inadequate AC supply, or excessive ambient temperatures may result in system malfunction.



ATTENTION: Remove and lock out power from the drive before you disconnect or reconnect wires or perform service. Wait three minutes after removing power to discharge the bus voltage. Do not attempt to service the drive until bus voltage has discharged to zero. Failure to do so may result in bodily injury or death.



ATTENTION: Do not connect power factor correction capacitors to output terminals U, V, and W. Doing so may result in equipment damage or bodily injury.



ATTENTION: Debris When Unpacking
 IRMDKG6-300W system is shipped with packing materials that need to be removed prior to installation. Failure to remove all debris and packing materials which are unnecessary for system installation may result in overheating or abnormal operating condition.

Hardware Description

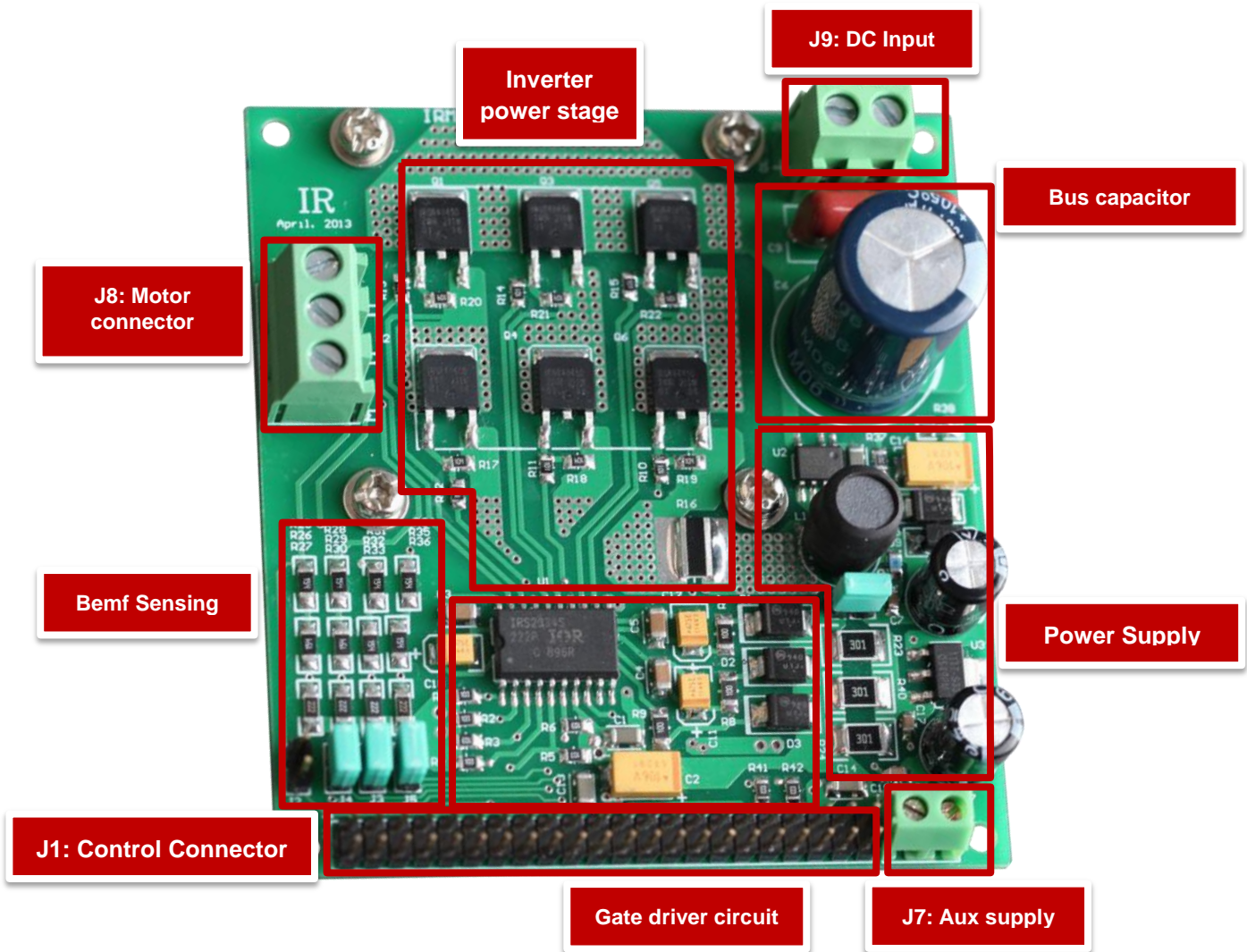

A top view of the IRMDKG6-300Wboard is shown below.

Connector definition

Pin	Name	Comments	Pin	Name	Comments
1	UHIN		23	PGND	
2	PGND		24	+3.3V	
3	ULIN		25	N.C.	
4	PGND		26	PGND	
5	VHIN		27	N.C.	
6	+3.3V		28	PGND	
7	VLIN		29	N.C.	
8	+3.3V		30	PGND	
9	WHIN		31	N.C.	
10	N.C.		32	N.C.	
11	WLIN		33	U sense	<i>connect through jumper (normally close)</i>
12	N.C.		34	V sense	<i>connect through jumper (normally close)</i>
13	N.C.		35	W sense	<i>connect through jumper (normally close)</i>
14	Vbus+(HV)	<i>connect through jumper (normally open)</i>	36	+3.3V	
15	PGND		37	SHUNT+	
16	N.C.		38	SHUNT-	
17	N.C.		39	N.C.	
18	PGND		40	PGND	
19	N.C.		41	N.C.	
20	Vbus sense		42	N.C.	
21	N.C.		43	N.C.	
22	N.C.		44	PGND	

Specifications

Parameters	Values	Conditions
Watts	300W	V _{in} =110VAC, f _{PWM} =10kHz, T _A =25°C, with heat-sink
Current	0.75Arms	
Maximum DC bus voltage	400V	
Current sensing device	Single DC shunt	
Power device	IRGR4610DPBF	
15V	15V+/-5%, Max 20mA	Used for gate drive power supply
3.3V	3.3V+/-5%, Max 50mA	Available on J1
PCB Material	FR4, Copper thickness=2oz (70um)	
Dimension	70mm x 87mm	
System environment		
Ambient temperature	0 to 70°C	95% RH max. (Non-condensing)

Running the system

1. Connect the system as in Figure 1
2. Power on the Vdc power supply (<400Vdc)
3. Start the control signal generator

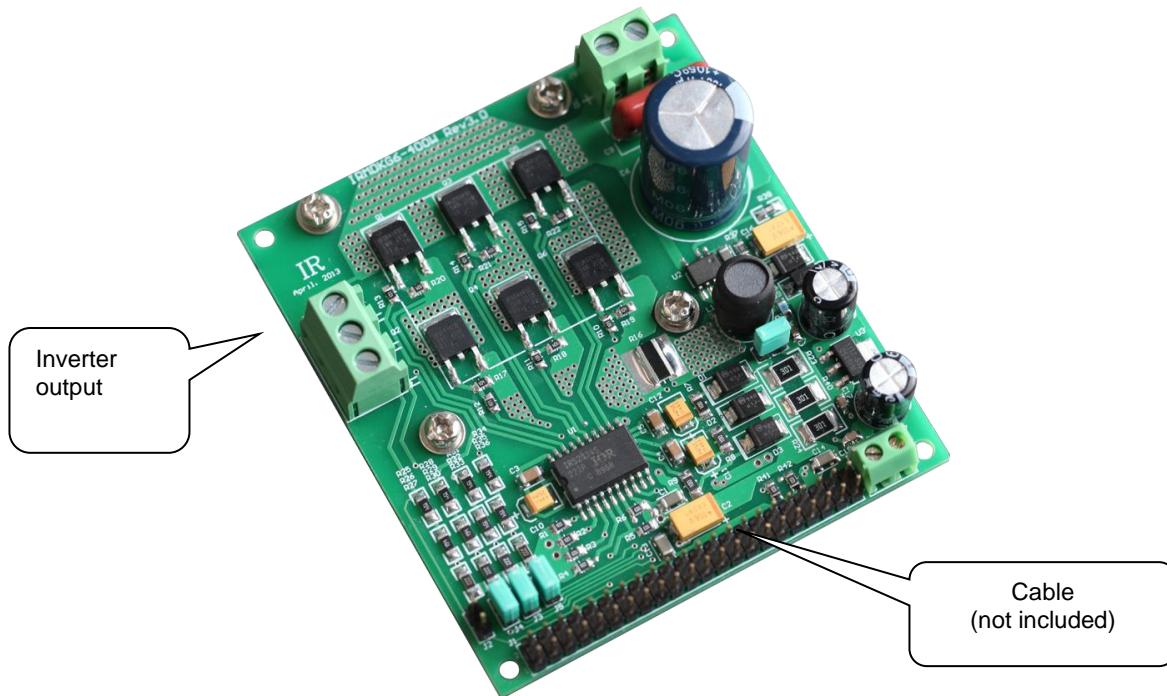

Figure 1 - Connection of control signals to the Dpak/D2PAK board

Test condition example

- PWM: IRMCF171 control board. Carrier frequency:16.6KHz
- Load: motor test bench
- Motor: GK6063-6AF31-WE(KE=63V/1000r/min, normal 1000rpm, I_o=2A)
- Power Board: DPAK board rev 3
- IGBT: IRGR4610DPBF

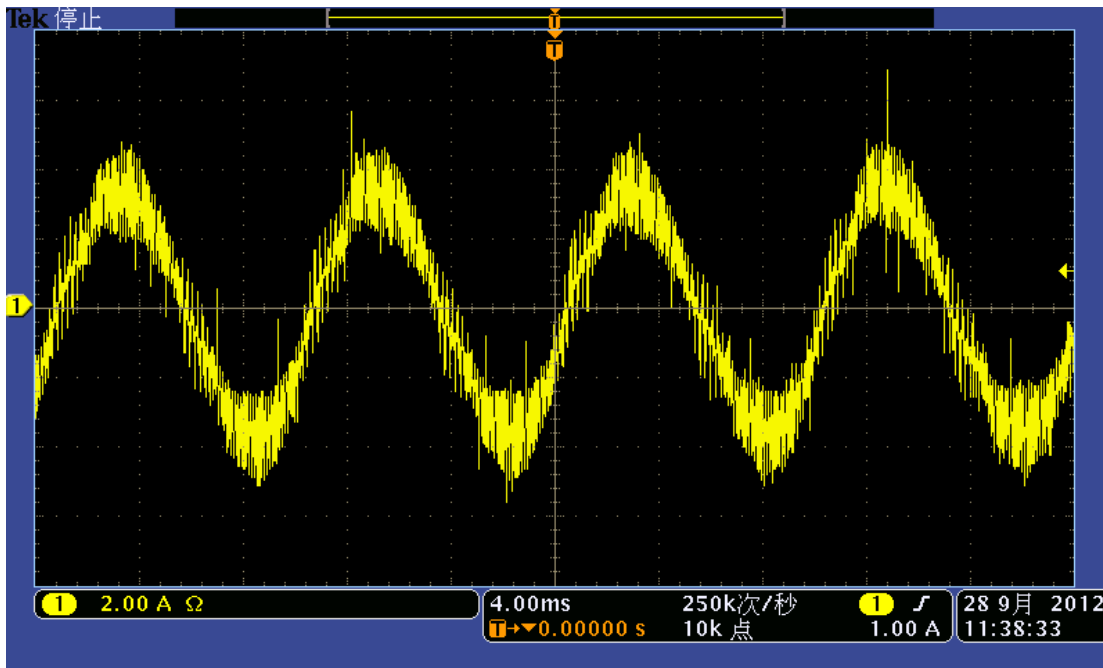

Figure 2 - Example of the inverter phase current for sinusoidal motor

The board can drive up to a 300W motor with the heatsink under the PCB bottom (see Figure 3)

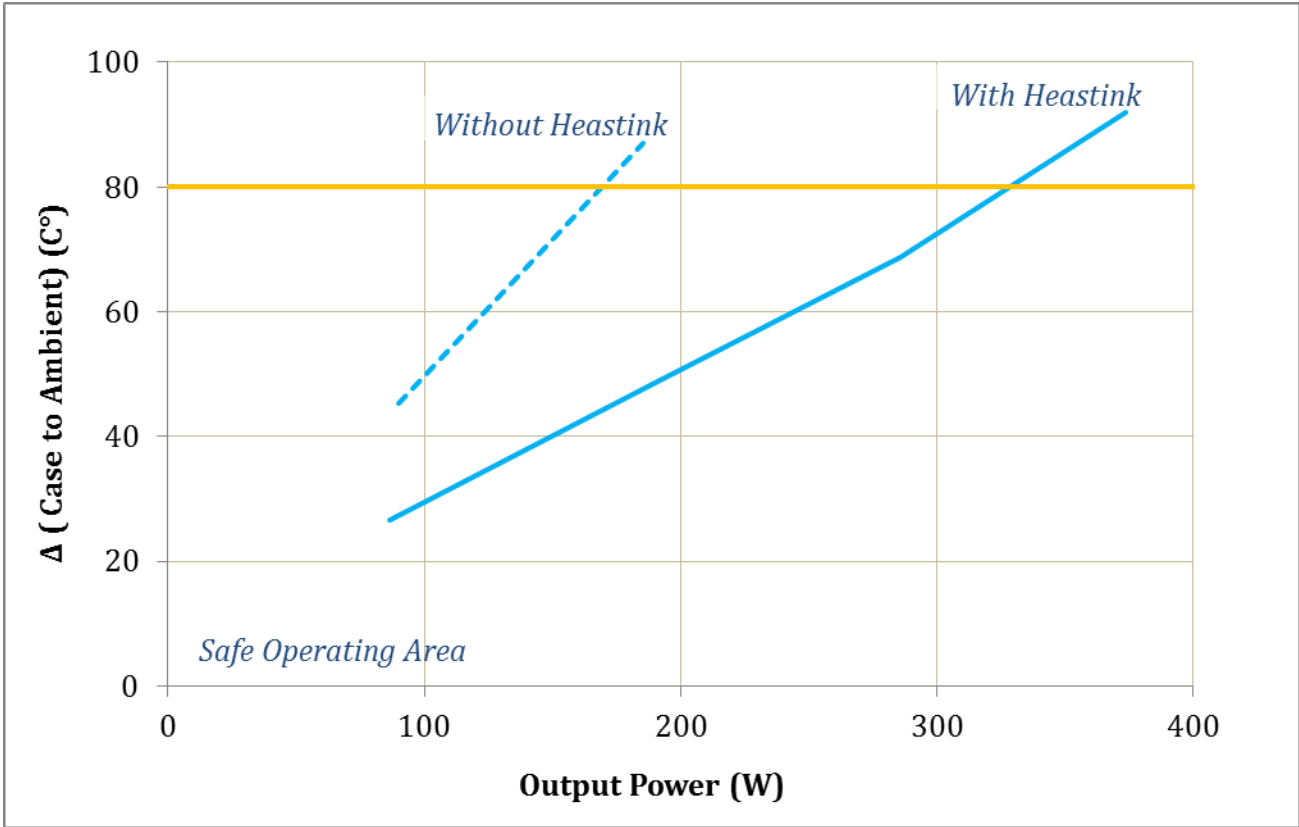

Figure 3 - Max PCB temperature vs Output power with heatsink

Revision History

International
 Rectifier

Data and Specifications are subject to change without notice

IR WORLD HEADQUARTERS: 233 Kansas St., El Segundo, California 90245, USA Tel: (310) 252-7105

TAC Fax: (310) 252-7903

Visit us at www.irf.com for sales contact information