

NOTE: ALL MATERIAL COMPLIANT REACH STANDARD

REVISION INFORMATION			
Rev.	Rev. Date	Modified By	Brief Description
A/0	19-04-24	T0424A	NEW DRAWING
A/1	19-05-14	B0514B	Remakes Color
A/2	19-07-22	B0722A	Add twist per inch

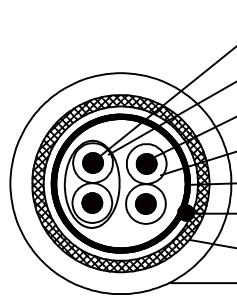

CONDUCTOR (1) : [28AWG (0.12/7) TINNED COPPER] X1PR
 INSULATION (1) : [PE ID:0.87±0.03] X1PR
 CONDUCTOR (2) : [28AWG (0.12/7) TINNED COPPER] X2C
 INSULATION (2) : [SR-PVC ID:0.87±0.03] X2C
 AL-MYLAR:
 DRAIN WIRE (0.12X7PCS) BARE STRANDED COPPER
 BRAID: (0.12/4/16) Almg
 JACKET:PVC UL2725 65P OD:3.8±0.15

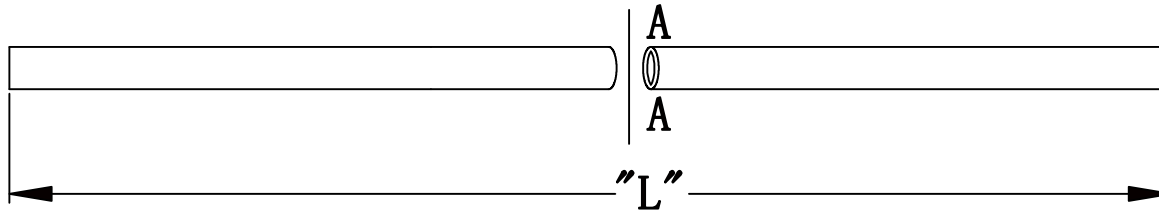
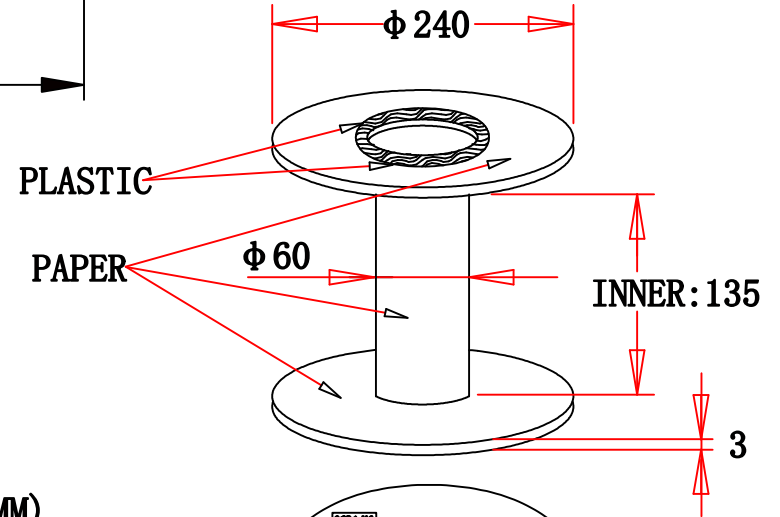

1. COLOR: (WHITE, GREEN) X1PR (1PR twist per inch is 15~18MM)
 (RED, BLACK) X2C (1PR+2C twist per inch is 70~80MM)

CABLE BLACK PRINT
 E166160 AWM 2725 80°C 30V
 28AWGX1P+28AWGX2C USB2.0

CnC Tech, LLC
 2725-2828-BE-01000-A
 1 PCS
 RoHS
 1821

P/N label

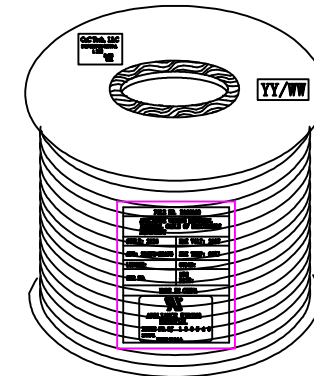
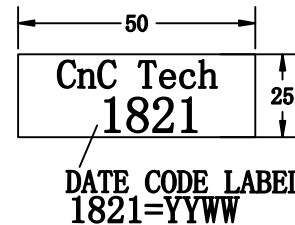

305M/R. "PE" FOAM WRAPPED

Parts number label:50X25mm stick on the reel

PART NO	WIRE LENGTH L	CABLE COLOR	INTERNAL COLOR CODE
2725-2828-BE-01000-A	305M/R		IV-29#

CnC Tech, LLC			
Industrial Cable and Connector Technology			
DRAWN BY:	DATE: 2019/07/22	DESCRIPTION: 305M/R UL2725 4C CABLE	
CHECKED BY:	SHEET 1 of 2	ITEM NO. 2725-2828-BE-01000-A	
APPROVED BY:	SCALE 1:1	REV. A/2	UNIT: mm

NOTE: ALL MATERIAL COMPLIANT REACH STANDARD

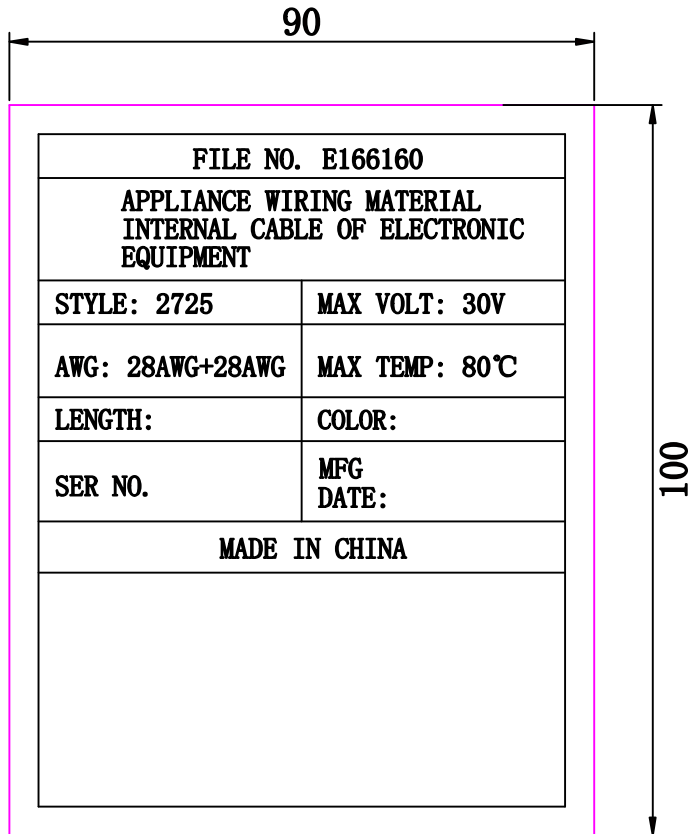

UL identification code

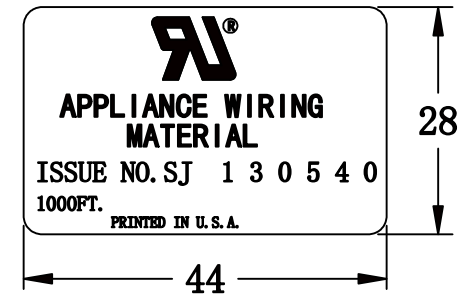

UL LABEL

CnC Tech, LLC			
Industrial Cable and Connector Technology			
DRAWN BY:	DATE: 2019/07/22	DESCRIPTION: 305M/R UL2725 4C CABLE	
CHECKED BY:	SHEET 2 of 2	ITEM NO. 2725-2828-BL-01000-A	
APPROVED BY:	SCALE 1:1	REV. A/2	UNIT: mm