

PRE-FEED 1/8" STROKE  
POST-FEED 5/8" STROKE

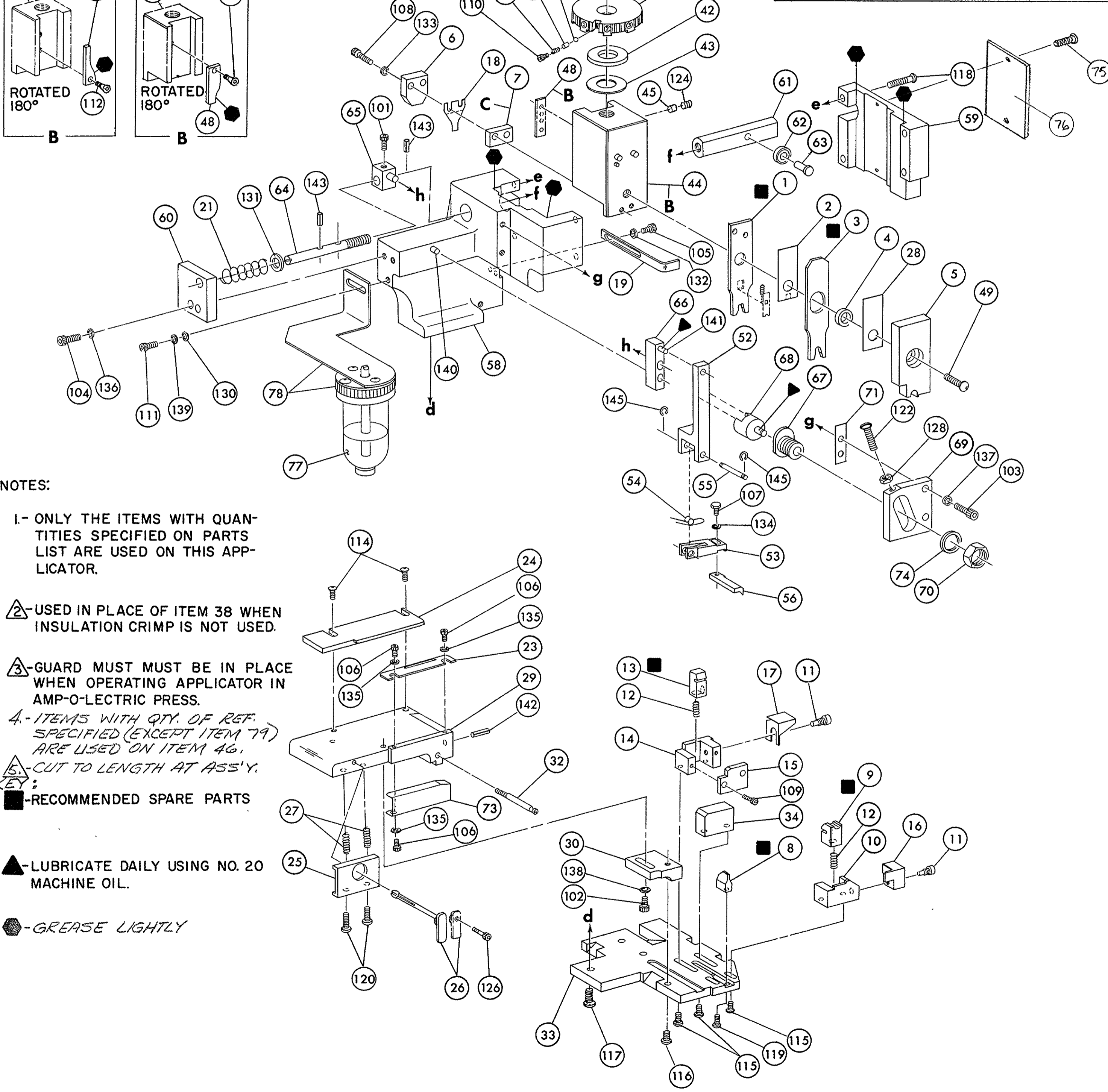
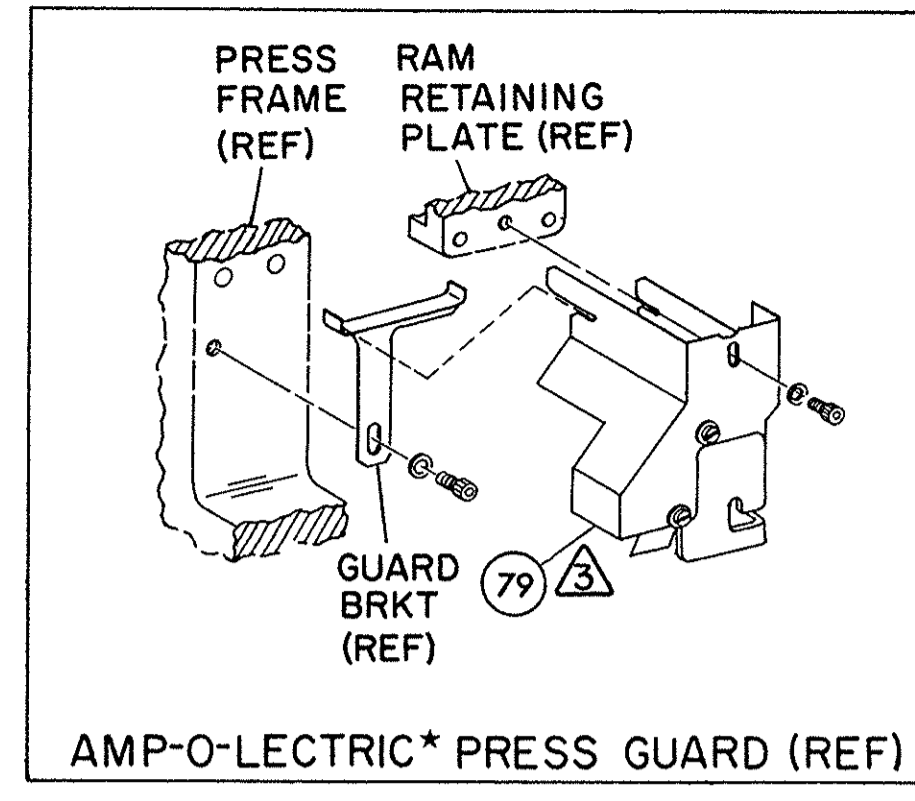
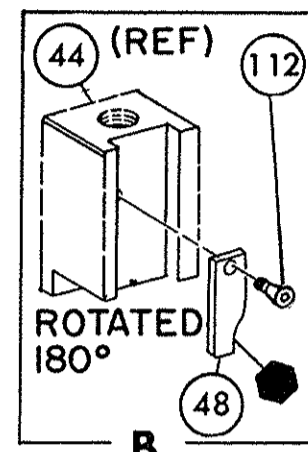
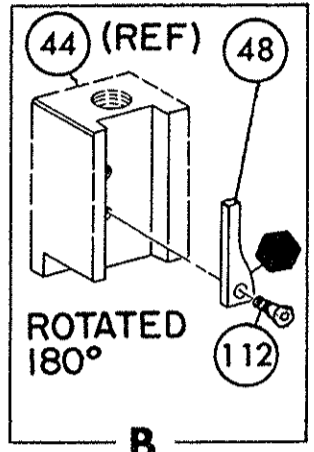

- NOTES:  
1- ONLY THE ITEMS WITH QUANTITIES SPECIFIED ON PARTS LIST ARE USED ON THIS APPLICATOR.  
2- USED IN PLACE OF ITEM 38 WHEN INSULATION CRIMP IS NOT USED.  
3- GUARD MUST BE IN PLACE WHEN OPERATING APPLICATOR IN AMP-O-LECTRIC PRESS.  
4- ITEMS WITH QTY. OF REF. SPECIFIED (EXCEPT ITEM 79) ARE USED ON ITEM 46.  
5- CUT TO LENGTH AT ASS'Y.  
KEY:  
■ - RECOMMENDED SPARE PARTS  
▲ - LUBRICATE DAILY USING NO. 20 MACHINE OIL.  
● - GREASE LIGHTLY

REF.	21045-3	RING, RETAINING 'C' (.187 DIA) FEED FINGER PIN	145	REF.	454220-1	CAP, HOUSING	59
REF.	5-21028-1	PIN, SLOT SPR (.125 DIA X .50) ADJ ROD	144	REF.	454485-1	HOUSING	58
1	4-21028-0	PIN, SLOT SPR (.093 DIA X .75) STR G PLATE	143				57
REF.	1-21030-1	PIN, DOWEL (.187 DIA X .50) LEVER	142	1	690542-2	PAWL, FEED	56
REF.	1-21030-6	PIN, DOWEL (.187 DIA X 1.25) HOUSING	141	REF.	240624-1	PIN, FEED FINGER	55
REF.	21024-5	WASHER, LOCK (NO 10) LUB ASSY	140	REF.	691499-1	SPRING, FEED FINGER	54
1	21024-5	WASHER, LOCK (NO 10) STRIP GUIDE ADJ BLOCK	139	REF.	690541-1	FINGER, FEED	53
REF.	21024-5	WASHER, LOCK (NO 10) STRIP GUIDE ADJ BLOCK	138	REF.	455679-1	LEVER, TERMINAL FEED ARM	52
REF.	21024-5	WASHER, LOCK (NO 10) ADJ PLATE	137	1	811242-2	BUMPER, HOLDDOWN	51
REF.	21024-5	WASHER, LOCK (NO 10) FEED GUIDE ROD	136	1	690753-1	SPACER, TONKER	50
3	21057-2	WASHER, LOCK (NO 4) FRONT STRIP GUIDE	135	1	7-21002-9	BOLT, CRIMPER	49
1	21024-4	WASHER, LOCK (NO 8) FEED FINGER	134	1	690501-4	CAM POST-FEED 1/8" STROKE	48
2	21024-4	WASHER, LOCK (NO 8) DEPRESSOR	133				47
1	21024-4	WASHER, LOCK (NO 8) STRIPPER	132	1	459456-1	APPLICATOR, BASIC (SUB ASSY)	46
REF.	21899-4	WASHER, FLAT (5/16 DIA) SCREW ADJ	131	1	690191-1	PLUG, NYLON	45
REF.	21899-2	WASHER, FLAT (NO 10) LUB ASSY	130	1	455673-1	RAM	44
1	21068-5	NUT, HEX MACH (6-32) HOLDDOWN	129	1	690125-1	WASHER, LAMINATED	43
REF.	21068-5	NUT, HEX MACH (6-32) FEED ADJ	128	1	690124-1	WASHER, RAM	42
			127			DISC, SPACER	41
1	22353-8	SCR, SHLD. (.187 DIA X .250 LG) DRAG LEVER	126	2	23241-6	BALL, STEEL	40
			125	2	690170-1	SPRING, COMPRESSION	39
1	21009-2	SCR, SKT SET (1/4-20 X .25) (LOC-WEL) RAM	124	1	690170-1	DISC, INSULATION	38
			123	1	690170-1	DISC, WIRE	37
REF.	6-23715-4	SCR, PAN HD MACH (6-32 X 1.25) FEED ADJ	122	1	22480-5	WASHER, SPRING	36
			121	1	690212-1	POST, RAM	35
2	3-21002-0	SCR, BUT HD SKT CAP (10-32 X .88) DRAG	120			SUPPORT, TERMINAL	34
1	22733-8	SCR, BUT HD SKT CAP (8-32 X .38) (LOC-WEL) ANVIL	119	REF.	455675-1	PLATE, BASE	33
REF.	2-21002-9	SCR, BUT HD SKT CAP (10-32 X .75) CAP	118	1	690432-3	SCREW, ADJUSTMENT	32
REF.	2-22733-8	SCR, BUT HD SKT CAP (1/4-20 X .62) HOUSING	117				31
REF.	2-21002-7	SCR, BUT HD SKT CAP (10-32 X .50) SG ADJ BLOCK	116	REF.	455689-1	BLOCK, STRIP GUIDE ADJ	30
2	2-21002-2	SCR, BUT HD SKT CAP (8-32 X .50) SHEAR	115	1	1-458144-3	PLATE, STRIP GUIDE	29
2	2-21000-2	SCR, BUT HD SKT CAP (8-32 X .50) R STRIP GUIDE	114	1	1-455888-0	SPACER, FRONT SHEAR DEPRESSOR	28
			113	2	1-22284-0	SPRING, DRAG	27
1	1-21002-7	SCR, BUT HD SKT CAP (6-32 X .38) CAM	112	1	240793-1	LEVER, DRAG RELEASE	26
			111	1	240792-1	DRAG, STOCK	25
2	23030-1	SCR, SKT HD CAP (6-32 X .25) (LOC-WEL) CP DISC	110	1	690504-8	GUIDE STRIP (REAR)	24
			109	1	690438-1	GUIDE STRIP (FRONT)	23
2	2-21000-7	SCR, SKT HD CAP (8-32 X .48) DEPRESSOR	108				22
1	2-22603-0	SCR, HEX HD MACH (8-32 X .31) FEED FINGER	107	REF.	4-22284-9	SPRING, FEED RETURN	21
3	1-21000-3	SCR, SKT HD CAP (4-40 X .25) F STRIP GUIDE	106				20
1	2-21000-7	SCR, SKT HD CAP (8-32 X .50) STRIPPER	105	1	690472-4	STRIPPER	19
REF.	3-21000-7	SCR, SKT HD CAP (10-32 X .75) FEED ROD GUIDE	104			HOLDER, TERMINAL	18
REF.	3-21000-6	SCR, SKT HD CAP (10-32 X .62) FEED ADJ BLOCK	103			GUARD, CHIP (REAR)	17
1	3-21000-4	SCR, SKT HD CAP (10-32 X .38) SG ADJ BLOCK	102	1	691667-1	GUARD, CHIP (FRONT)	16
REF.	3-21000-4	SCR, SKT HD CAP (10-32 X .38) PIVOT BLOCK	101			PLATE, SHEAR (REAR)	15
REF.	455749-1	GUARD, WINDOW	79			HOLDER, SHEAR (REAR)	14
	1-465184-0	LUBRICATOR ASSY	78			SHEAR, FLOAT (REAR)	13
		OIL, LUBRICATING	77	1	5-22280-0	SPRING, SHEAR	12
1	461264-1	PLATE, IDENTIFICATION	76	1	690461-1	STOP, SHEAR	11
2	21017-2	SCR, DRIVE (2 X .19) ID PLATE	75	1	690459-1	HOLDER, SHEAR (FRONT)	10
REF.	458109-1	WASHER, SPECIAL	74	1	454876-1	SHEAR, FLOAT (FRONT)	9
1	454877-3	PLATE, STRIP GUIDE COVER	73	1	454910-1	ANVIL	8
2	690603-1	SPRING, ASSIST	72			SPACER, DEPRESSOR (REAR)	7
REF.	690517-1	SPACER	71			DEPRESSOR, SHEAR (REAR)	6
	22594-8	NUT, HEX	70	1	455889-9	DEPRESSOR, SHEAR (FRONT)	5
	240628-1	PLATE, ADJUSTMENT	69	1	1-238011-0	SPACER, TUBULAR, INS CRIMPER	4
	240626-1	SHAFT, PIVOT	68	1	5-683454-0	CRIMPER, INSULATION	3
	240633-1	BUSHING	67	1	455888-5	SPACER, CRIMPER	2
	455680-1	LEVER, INTERMEDIATE	66	1	1-456404-8	CRIMPER, WIRE	1
	240629-1	BLOCK, PIVOT	65				
	240632-2	SCREW, ADJUSTMENT FEED ROD	64				
	240659-3	PIN, CAM ROLLER	63				
	240658-1	ROLLER, CAM	62				
	454398-2	ROD, FEED	61				
REF.	454178-1	GUIDE, FEED ROD	60				

REMARKS	NO	REV
TO APPLY TERMINAL APPL SPEC 114-2082		
APPL USED ON MACHINE PART NO	MACH SERIAL NO	DISTRIBUTION
CUSTOMER NAME	APPL SERIAL NO	ORIGINAL
ADDRESS	PURCHASE ORDER	CUSTOMER COPY
CITY	ENG APP	FIELD ENG COPY

CRIMPING DATA				APPLICATOR WILL APPLY
PAD LTR	CRIMP HEIGHT	WIRE SIZE	WIRE LENGTH	
A	.046	18		61964
B	.040	20		62003
C	.037	22		62374
D	NOT USED			62929
				* 63242
				63961-1

CRIMP	SIZE	TYPE	FEED	APPL INST
WIRE	.070	F		A1 8040
INSUL	.140	O	.440	

WIRE RANGE 22-18 INSULATION RANGE .060-.100\* PRESS NO -

REMARKS POST-FEED AMPOMATOR FEED SIDE ONLY

▲ GUIDE OFF INSULATION BARREL

\* INS. RANGE OF 63242 IS .080 TO .120

E	ECN A-40592	10-92	SET UP GAGE 10-1
D	ECN A15788	11-88	458637-1-460
C	ECN A-095788	09-92	DR 9-92 APP
B	REV PER ECN R-4689	08-92	11-92
B	REV PER ECN R-3101	07-92	11-92
B	REV PER R-2666	08-79	CHK 8-79
A	REV PER ECN R1756	08-79	11-92

PIF LTR REVISION RECORD APP DATE PIF LTR REVISION RECORD APP DATE



MINIATURE QUICK CHANGE APPLICATOR SIDE FEED (.110 FASTON PIGGY-BACK)