

REVISIONS				
REV	ECO	DESCRIPTION	DATE	BY APPR
A1	-	RELEASED DRAWING	Jul-16-18	Flan Tommy

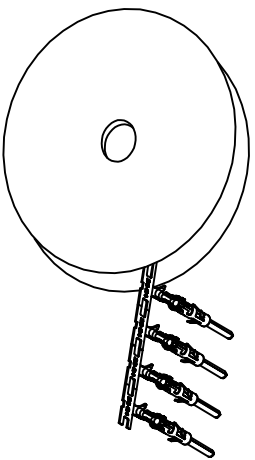

CONTACT ORIENTATION ON ROLL(3000PCS/COIL)

NOTES : (UNLESS OTHERWISE SPECIFIED)  
 1. MATERIAL :

- 1.1. CONTACT BODY : COPPER ALLOY.
- 1.2. OUTER SPRING : STAINLESS STEEL.

2. SPECIFICATIONS :

- 2.1 CURRENT RATING : 13A MAX.
- 2.2 TERMINATION TYPE : CRIMPING.
- 2.3 WIRE RANGE : 26~24AWG.
- 2.4 WIRE INSULATION DIA(MAX) :  $\phi$ 2.1mm.

3. RoHS COMPLIANT.

4. ALL DIMENSIONS ARE FOR REFERENCE USE ONLY.

5. AVAILABLE TOOLS :

- 5.1 HAND CRIMPER : MFX-3954.
- 5.2 CRIMP APPLICATOR : MFX-3957.
- 5.3 EXTRACTION TOOL : QXRT16.

P/N	CONTACT PLATING(MATING AREA)
SP24M2T	TIN PLATING OVER NICKEL.
SP24M2N	NICKEL PLATING OVER COPPERIZE.
SP24M2F	GOLD FLASH PLATING OVER NICKEL.
SP24M2G5	5 $\mu$ "GOLD PLATING OVER NICKEL.
SP24M2G10	10 $\mu$ "GOLD PLATING OVER NICKEL.
SP24M2G15	15 $\mu$ "GOLD PLATING OVER NICKEL.
SP24M2G30	30 $\mu$ "GOLD PLATING OVER NICKEL.

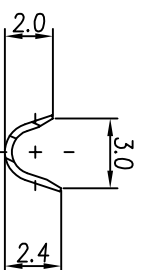
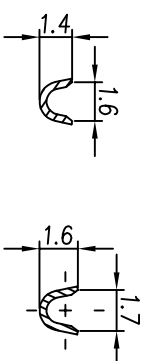
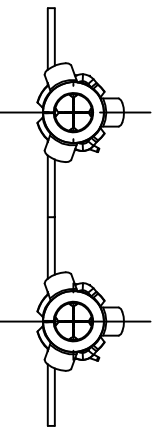
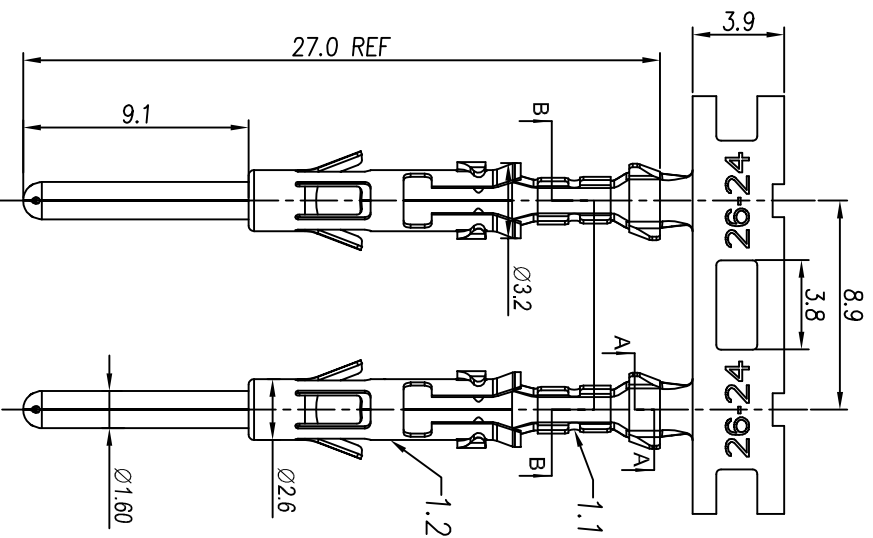

QUANTITY	PART NUMBER	DESCRIPTION	ITEM
<b>MATERIALS LIST</b>			
UNLESS OTHERWISE SPECIFIED 1) All dimensions are in millimeters. 2) Tolerances are as follows: 1 PL DEC 240.30 Fractions, 3 1/4 3 PL DEC 240.08 Fractions, 4 1/4 3) Note reference = $\Delta$			
PROCESS SPECIFICATIONS:		MATERIAL SPECIFICATIONS:	
NEXT ASSY:		CUSTOMER: Tommy Jul-16-18	
THIS DRAWING IS SUPERSEDED BY THE LATEST REVISIONS. SPECIFICATIONS AND PERFORMANCE DATA ARE SUBJECT TO CHANGE WITHOUT NOTICE. THE MANUFACTURING CORPORATION NO RIGHTS OF REPRODUCTION ARE GRANTED. ALL MANUFACTURING VARIATIONS.		ECO-MATE PIN CONTACT. STAMPED.26-24AWG.SIZE 16	
SCALE: NONE	SIZE: B	DWG NO: SP24M2XX	REVISION: A1

**Amphenol**

Sine Systems - www.amphenol-sine.com  
 44724 Morley Drive  
 Clinton Township, MI 48036