

**FLANGE MOUNT STRAIGHT JACK SOLDER TYPE  
CAB.0.85**

**R143.272.700  
SERIES TNC 18**

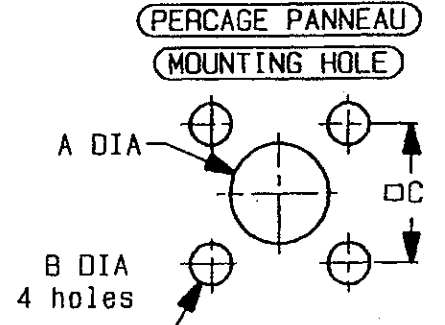
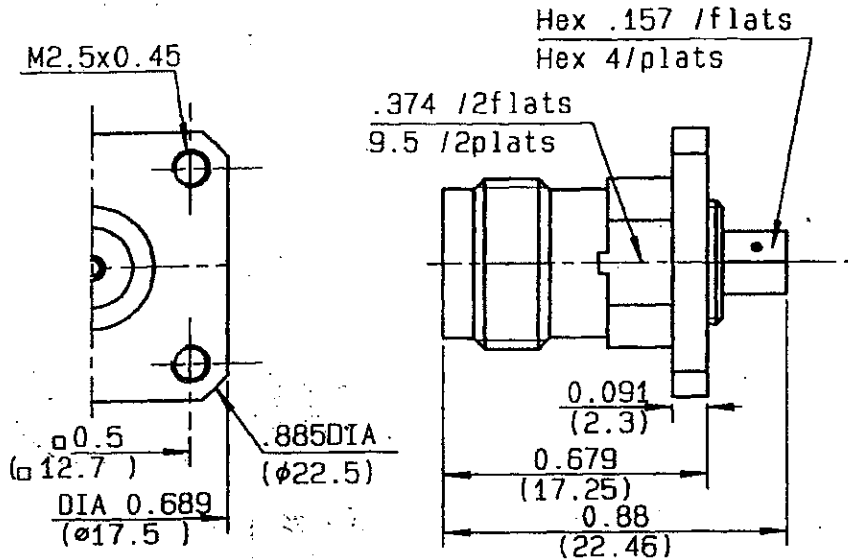

	MM		INCH	
	maxi	mini	maxi	mini
A	8.15	8.05	0.321	0.32
Ab	11.3	11.2	0.445	0.44
B	2.7	2.6	0.106	0.102
C	12.75	12.65	0.502	0.498

NOMINAL IMPEDANCE	50	Ω
FREQUENCY RANGE	0-18	GHz
TEMPERATURE RATING	<b>-65/+165°C</b>	
V.S.W.R	1.10 + .015 x F(GHz)Maxi	
RF INSERTION LOSS	0.06 √F(GHz) dB Maxi	
VOLTAGE RATING	335	Veff Maxi
DIELECTRIC WITHSTANDING VOLTAGE	1000	Veff Mini
INSULATION RESISTANCE	5000	M ΩMini
HERMETIC SEAL	NA	Atm.cm <sup>3</sup> /s
LEAKAGE (pressurized only)	NA	MPa

CABLES : KS 1  
RG 405

**\*Performances may be limited by the cable linked to the connector.**

MCHANICAL DURABILITY	Cycles
CGTH	10.3 gr

OTHERS CHARACTERISTICS

CABLE RETENTION	136	N Mini
CENTER CONTACT RETENTION		
Axial force - mating end	NA	N Mini
Axial force - opposite end	NA	N Mini
Torque	NA	cm.N Mini
RECOMMENDED TORQUES		
Mating	NA	cm.N
Panel nut	NA	cm.N
Clamp nut	200	cm.N

CONNECTOR PARTS	MATERIALS	FINISH	(all values are given in micrometers)
BODY	STAINLESS STEEL	PASSIVATED	
OUTER CONTACT			
CENTER CONTACT	BERYLLIUM COPPER	GOLD	
INSULATOR	PTFE	-	
GASKET	SILICONE RUBBER	-	
OTHERS PIECES	STAINLESS STEEL	GOLD	

ISSUE	CREATION DATE	FILE PART-NUMBER
<b>1045A</b>	<b>16-JUL-90</b>	<b>90-0014-026</b>



The information given here is subject to change without notice. Design changes may be in order to improve the product.

*Connect to the future*

RADIALL



**R143.272.700**

ISSUE 9615A

SERIES TNC 18

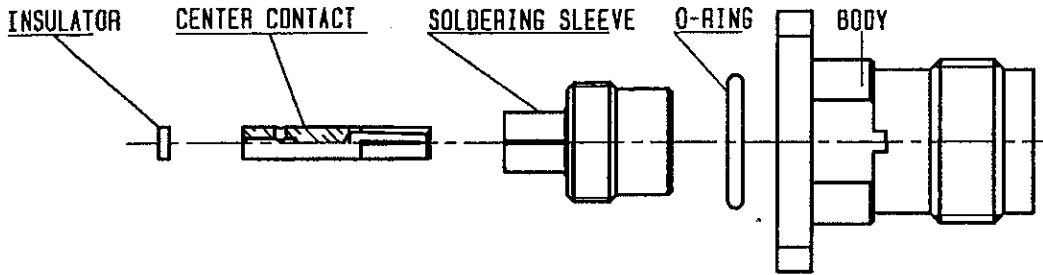

①

Strip the dielectric of the cable.  
 Stripping tool cable: R 282 051.  
 Trim inner conductor cable.  
 Hammer : R 282 063  
 Flatten the cable.

TOOLBOX R282 114 125

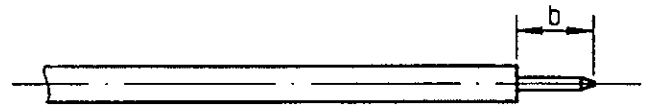

Stripping	a	b	c	d	e
inch	0	0.125 0	0	0	0
mm		3.17			

②

Mount the insulator on the cable inner conductor.  
 Mount the center contact on the cable inner conductor.  
 Solder the center contact.

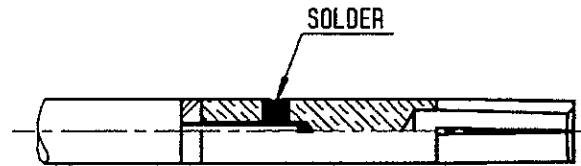

③

Screw positionner R 282 744 000 into the connector.  
 Push cable into the connector until it bottoms against positionner R 282 744 000  
 Tighten with assembly jig R 282 740 020  
 Put 3 rings of solder around the cable and solder.

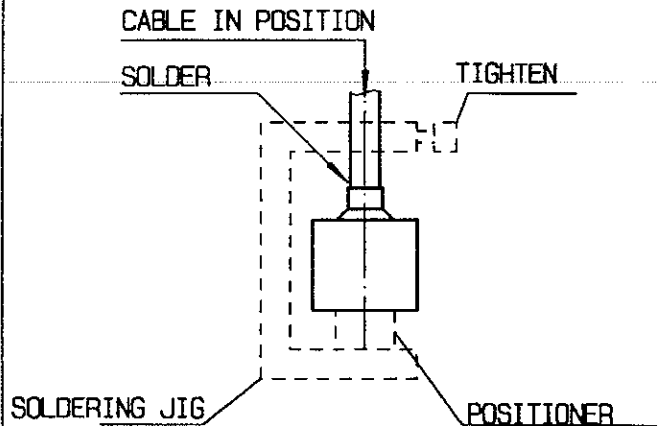

④

After cooling remove cable assembly from the jig.  
 Place the o-ring into the body.  
 Screw the body on the solder sleeve.  
 Recommended torque : 200 Ncm

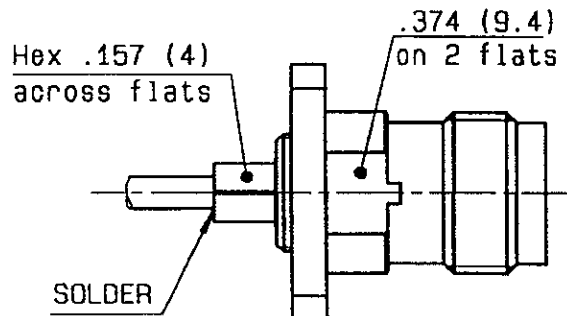

RADIALL



Connect to the future

**R143.272.700**

ISSUE 9615A

SERIES TNC 18

④

Screw on the positioner, which shall abut against the solder sleeve.  
 Mount the cable, abutting against the positioner R282.744.000  
 Solder the sleeve on the semi-rigid cable.

-  
-  
-

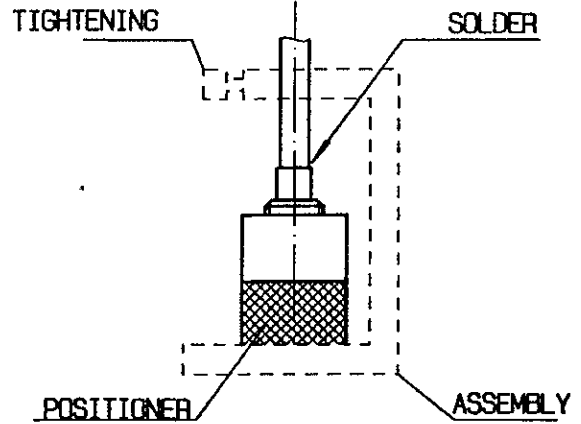

Mount the connector on the sleeve and lock it.  
 Recommended tightening : 200 cmN.

-  
-

