

NOTES: (UNLESS OTHERWISE SPECIFIED)

1. MATERIAL:
 - 1.1. CONTACT BODY: COPPER ALLOY.
 - 1.2. OUTER SPRING: STAINLESS STEEL.
2. SPECIFICATIONS:
 - 2.1 CURRENT RATING: 5A MAX.
 - 2.2 TERMINATION TYPE: CRIMPING.
 - 2.3 WIRE RANGE: 22-20AWG.
 - 2.4 WIRE INSULATION DIA(MAX): Ø2.6mm.
3. RoHS COMPLIANT.
4. ALL DIMENSIONS ARE FOR REFERENCE USE ONLY.
5. AVAILABLE TOOLS:
 - 5.1 HAND CRIMPER: MFX-3958 ^(A3)
 - 5.2 CRIMP APPLICATOR: MFX-3957.
 - 5.3 EXTRACTION TOOL: QXRT20.

P/N	CONTACT PLATING(MATING AREA)
SP20W2T	TIN PLATING OVER NICKEL.
SP20W2N	NICKEL PLATING OVER COPPERIZE.
SP20W2F	GOLD FLASH PLATING OVER NICKEL.
SP20W2G5	5µ" GOLD PLATING OVER NICKEL.
SP20W2G10	10µ" GOLD PLATING OVER NICKEL.
SP20W2G15	15µ" GOLD PLATING OVER NICKEL.
SP20W2G30	30µ" GOLD PLATING OVER NICKEL.

(A2)

REVISIONS					
REV	ECO	DESCRIPTION	DATE	BY	APPR
A1	-	RELEASED DRAWING	Nov-8-17	Rookie Tommy	Tommy
A2	-	ADD THE GS PART NUMBER	Jan-28-19	Blink Tommy	Tommy
A3	-	CHANGE HAND CRIMPER	Nov-8-19	Flan Tommy	Tommy

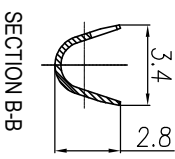
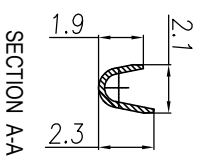
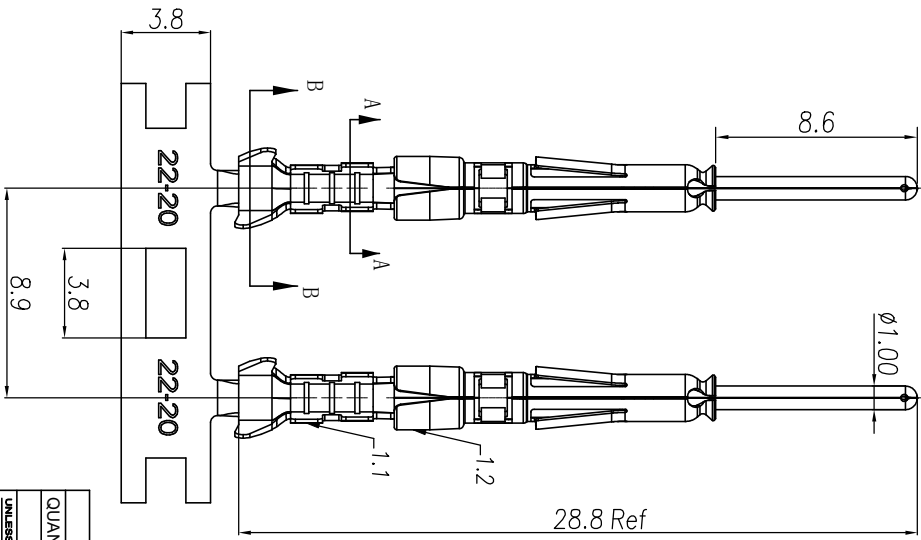

QUANTITY	PART NUMBER	DESCRIPTION	ITEM

MATERIALS LIST

UNLESS OTHERWISE SPECIFIED
 1) All dimensions are in millimeters.
 2) Tolerances are as follows:
 1 Pk DEC 2018
 1 Pk DEC 2019
 3 Pk DEC 2018
 3) Note reference = **Warning**

SIGNATURES

DRAWN	DATE
Rui	Nov-8-19
Mih	Nov-8-19

CHECKED: **Mih** DATE: **Nov-8-19**
 ENGINEER: _____
 APPROVE: **Tommy** DATE: **Nov-8-19**

CUSTOMER: _____

THE DRAWING IS SUBJECT TO THE SPECIFICATIONS AND PERFORMANCE DATA OF THE MANUFACTURING PROCESS. THE MANUFACTURING CORPORATION ACCEPTS NO RESPONSIBILITY FOR REPRODUCTION AND ALL RIGHTS OF REPRODUCTION ARE RESERVED. ALL MANUFACTURING VARIATIONS

ECO-MATE PIN CONTACT.
 STAMPED: 20-22AWG, SIZE 20

Amphenol
 Sine Systems - www.amphenol-sine.com
 44724 Montey Drive
 Clinton Township, MI 48038

SIZE: **B** TYPE: **C-** DWG NO: **SP20W2XX** REVISION: **A3**

SCALE: NONE SHEET: 1 OF 1

TITLE: ECO-MATE PIN CONTACT, STAMPED, 22-20AWG, SIZE 20

DWG NO: SP20W2XX

REV: A3

SH: 1

OF 1