

CKTS	A	B	C
02	.262 6.65	NA	.169 4.30
04	.380 9.65	.118 3.00	.287 7.30
06	.498 12.65	.236 6.00	.405 10.30
08	.616 15.65	.354 9.00	.524 13.30
10	.734 18.65	.472 12.00	.642 16.30
12	.852 21.65	.591 15.00	.760 19.30
14	.970 24.65	.709 18.00	.878 22.30
16	1.088 27.65	.827 21.00	.996 25.30
18	1.206 30.65	.945 24.00	1.114 28.30
20	1.325 33.65	1.063 27.00	1.232 31.30
22	1.443 36.65	1.181 30.00	1.350 34.30
24	1.561 39.65	1.299 33.00	1.469 37.30

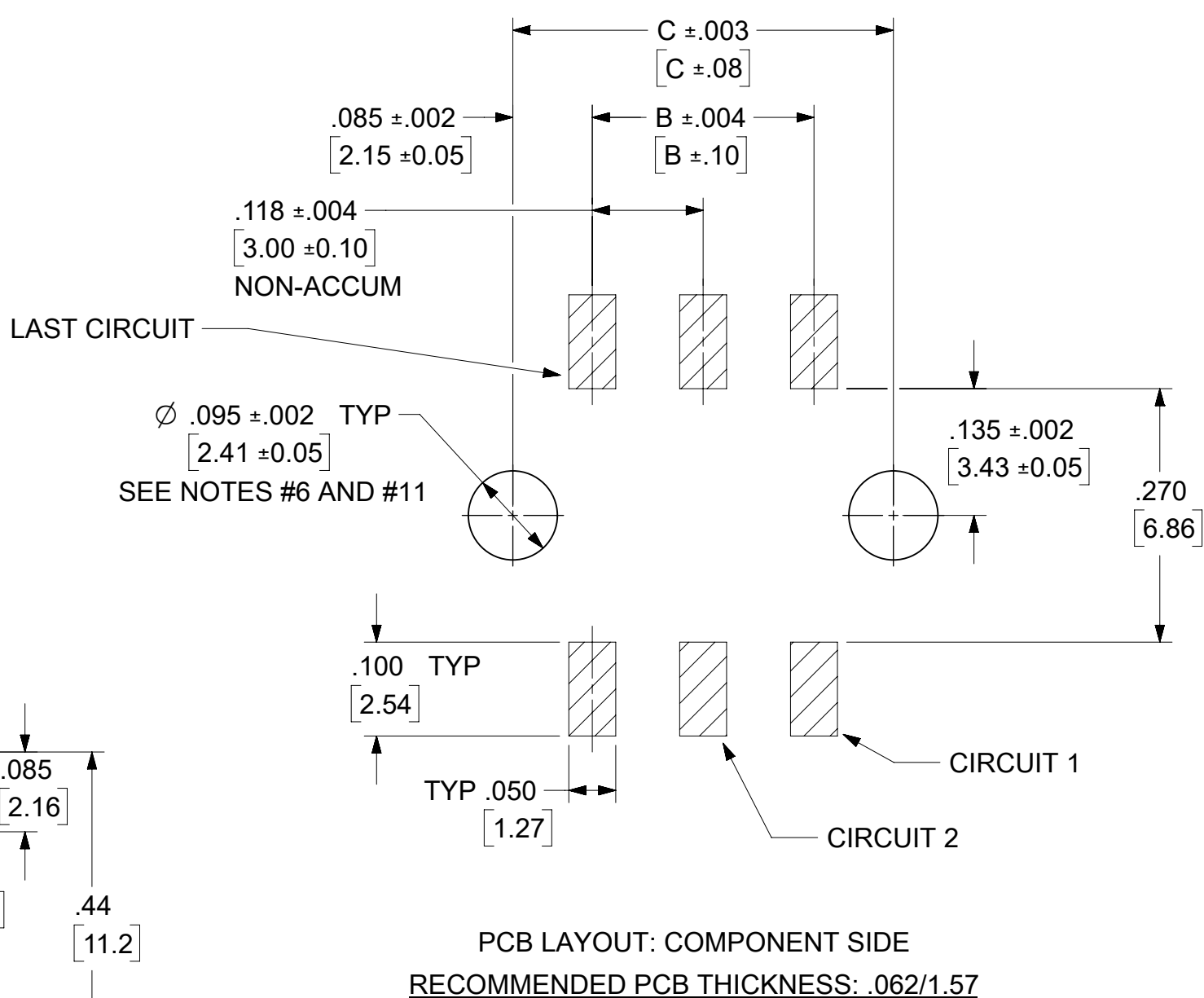

- NOTES:**
- HOUSING MATERIAL: GLASS FILLED LIQUID CRYSTAL POLYMER, UL94V-0, COLOR-BLACK
TERMINAL MATERIAL: BRASS ALLOY
 - FINISH: A = .000060/(0.00152) MIN. REFLOW MATTE TIN OVER .000050/(0.00127) MIN. NICKEL PLATE. (FINISH IS BRIGHT IN APPEARANCE, THICKNESS AS APPLIED PRIOR TO REFLOW)
B = .000015/(0.00038) MIN. SELECT GOLD IN CONTACT AREA; .000100/(0.00254) MIN. SELECT MATTE TIN ON SOLDER TAILS; BOTH OVER .000050/(0.00127) MIN. NICKEL PLATE.
C = .000030/(0.00076) MIN. SELECT GOLD IN CONTACT AREA; .000100/(0.00254) MIN. SELECT MATTE TIN ON SOLDER TAILS; BOTH OVER .000050/(0.00127) MIN. NICKEL PLATE.
D = .000100/(0.00254) MIN. MATTE TIN OVER .000050/(0.00127) MIN. NICKEL PLATE
 - PRODUCT SPECIFICATION: PS-43045
 - TAPE AND REEL PACK : SEE MOLEX DRAWING 430450002-PK
 - MATES WITH MICRO FIT (3.0) RECEPTACLE SERIES 43025
 - TO MINIMIZE INSERTION FORCE OF MOUNTING CLIPS DURING ROBOTIC PLACEMENT THE HOLE DIAMETER SHOULD BE INCREASED TO .108±.002 / 2.74±0.05 AND THEN EVALUATED PER PLACEMENT EQUIPMENT.
 - THE COPLANARITY DIMENSION IS ESTABLISHED BY PLACING THE ASSEMBLY ON A FLAT SURFACE. THE DISTANCE FROM THAT SURFACE TO THE BOTTOM OF ANY TERMINAL MUST NOT EXCEED .004/0.10
 - CIRCUIT SIZES 2-6: "D" IS 0.265/6.74 FOR .010/0.25 STEP. CIRCUIT SIZES 8-24: "D" IS .063/1.60 FOR .010/0.25 STEP.
 - THIS PART CONFORMS TO CLASS B REQUIREMENTS OF COSMETIC SPECIFICATION PS-45499-002.
 - TEXT ON THE PART IS FOR REFERENCE ONLY. TEXT AND TEXT LOCATION MAY VARY DEPENDING ON PART NUMBER AND/OR TOOL.
 - HOLES FOR CLIPS SHOULD BE PTH AND CLIPS SHOULD BE SOLDERED FOR BEST RETENTION TO PCB.

	FINISH A	FINISH B	FINISH C	FINISH D
CIRCUITS	MATERIAL NO:	MATERIAL NO:	MATERIAL NO:	MATERIAL NO:
02	43045-0215	43045-0216	43045-0217	43045-0320
04	43045-0415	43045-0416	43045-0417	43045-0520
06	43045-0615	43045-0616	43045-0617	43045-0720
08	43045-0815	43045-0816	43045-0817	43045-0920
10	43045-1015	43045-1016	43045-1017	43045-1120
12	43045-1215	43045-1216	43045-1217	43045-1320
14	43045-1415	43045-1416	43045-1417	43045-1520
16	43045-1615	43045-1616	43045-1617	43045-1720
18	43045-1815	43045-1816	43045-1817	43045-1920
20	43045-2015	43045-2016	43045-2017	43045-2120
22	43045-2215	43045-2216	43045-2217	43045-2320
24	43045-2415	43045-2416	43045-2417	43045-2520

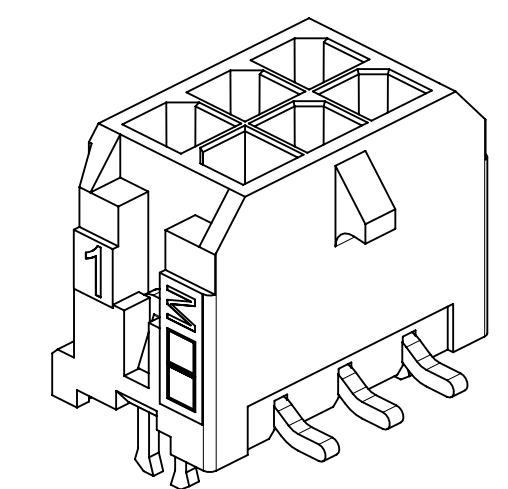
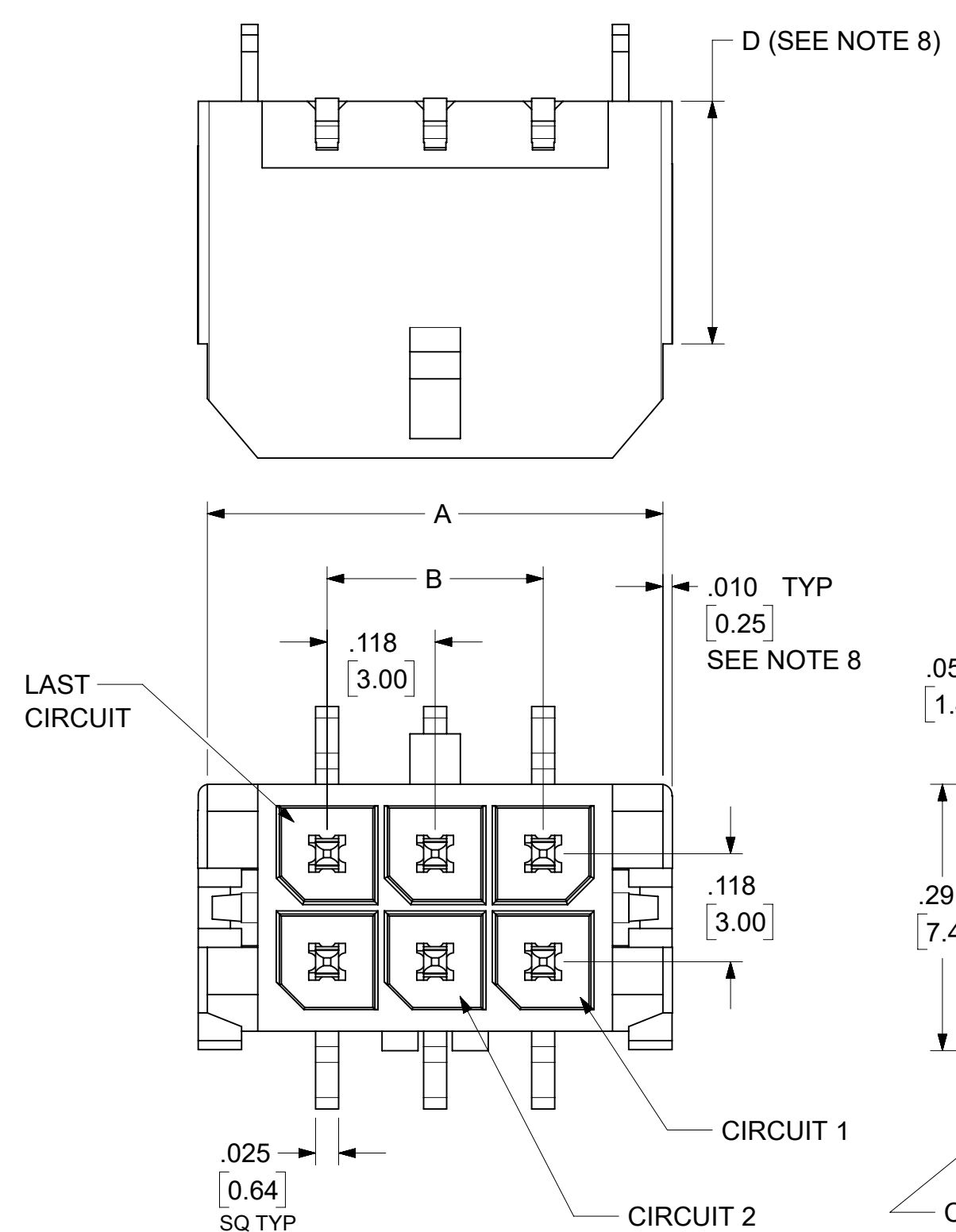
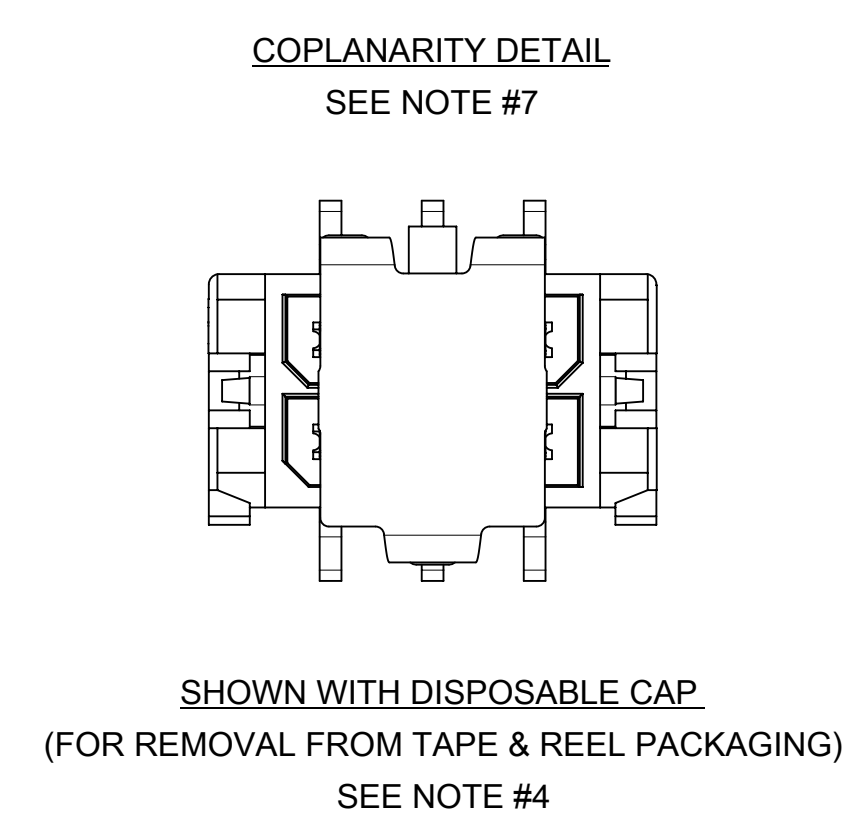
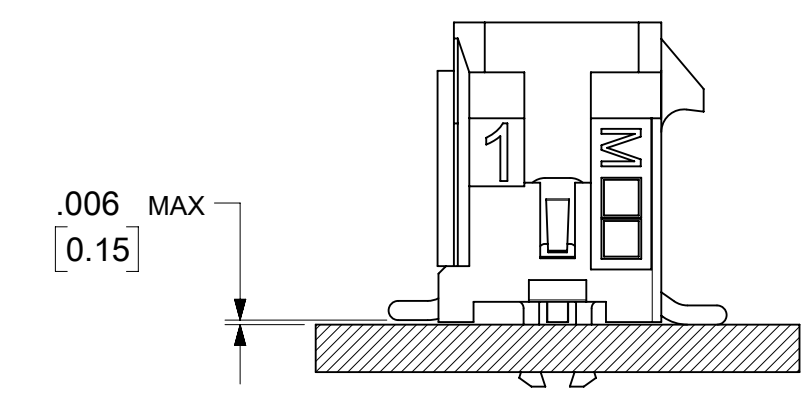

FUNCTIONAL SYMBOLS	THIS DRAWING CONTAINS INFORMATION THAT IS PROPRIETARY TO MOLEX ELECTRONIC TECHNOLOGIES, LLC AND SHOULD NOT BE USED WITHOUT WRITTEN PERMISSION		CURRENT REV DESC: REDRAWN, ADD NOTE 10	
	DIMENSION UNITS	SCALE		
$F_A = 0$	INCH/MM	NTS		
$F_C = 0$	GENERAL TOLERANCES (UNLESS SPECIFIED)			
$F_P = 0$		MM	INCH	
DIVISIONAL SYMBOLS	4 PLACES	±	±	
	3 PLACES	±	± 0.01	
	2 PLACES	± 0.25	± 0.014	
	1 PLACE	± 0.36	±	
	0 PLACES	±	±	
	ANGULAR TOL	± 0.5 °		
DRAFT WHERE APPLICABLE MUST REMAIN WITHIN DIMENSIONS		THIRD ANGLE PROJECTION	DRAWING	SERIES
			C-SIZE	43045
		EC NO: 736143	DRWN: SETHH6	2022/12/14
		CHK'D: MKIPPER	APPR: FSMITH	2023/01/24
		INITIAL REVISION:	DRWN: SAMIEC	2000/03/15
			APPR: FSMITH	2016/08/03
DOCUMENT STATUS		P1	RELEASE DATE	2023/01/26 18:55:51
DOCUMENT NUMBER		CUSTOMER		SHEET NUMBER
SD-43045-006		GENERAL MARKET		1 OF 1