

CATALOG NUMBER	MATERIAL NUMBER	CABLE RANGE	LENGTH "M"	LENGTH "B"	ROD LENGTH	ROD DIAMETER REF.	BREAK STRENGTH* (LBS/N)	SHOULDER PROTECTOR	UL LISTED	CSA APPROVED	PRODUCT SELECTION NUMBER
36140	1300950253	.50-.61 / 12.7-15.5	7.00±1.00 / 177.8±25.4	7.00±1.00 / 177.8±25.4	11.00±0.50 / 279.4±12.7	.093 / 2.36	1800 / 8007	YES	NO	YES	SRK050-1
36141	1300950255	.62-.74 / 15.7-18.8	9.00±1.50 / 228.6±38.1	7.00±1.00 / 177.8±25.4	13.00±0.50 / 330.2±12.7	.093 / 2.36	1900 / 8452				SRK062-1
36142	1300950256	.75-.99 / 19.1-25.1	11.00±1.50 / 279.4±38.1	7.00±1.00 / 177.8±25.4	15.00±0.50 / 381.0±12.7	.093 / 2.36	3000 / 13345				SRK075-1
36143	1300950257	1.00-1.24 / 25.4-31.5	12.00±1.50 / 304.8±38.1	8.00±1.00 / 203.2±25.4	16.00±0.50 / 406.4±12.7	.093 / 2.36	4100 / 18238	NO	NO	YES	SRK100-1
36144	1300950258	1.25-1.49 / 31.8-37.8	14.00±1.50 / 355.6±38.1	8.00±1.00 / 203.2±25.4	19.00±0.50 / 482.6±12.7	.125 / 3.18	5700 / 25355				SRK125-1
36145	1300950259	1.50-1.74 / 38.1-44.2	16.00±2.00 / 406.4±50.8	9.00±1.00 / 228.6±25.4	21.00±1.00 / 533.4±25.4	.125 / 3.18	5800 / 25800				SRK150-1
36146	1300950260	1.75-1.99 / 44.5-50.5	17.00±2.00 / 431.8±50.8	10.00±1.00 / 254.0±25.4	22.00±1.00 / 558.8±25.4	.125 / 3.18	7700 / 34251				SRK175-1
36147	1300950261	2.00-2.49 / 50.8-63.2	20.00±2.00 / 508.0±50.8	10.00±1.00 / 254.0±25.4	25.00±1.00 / 635.0±25.4	.156 / 3.96	9300 / 41368				SRK200-1
36148	1300950262	2.50-2.99 / 63.5-75.9	21.00±2.50 / 533.4±63.5	10.00±1.00 / 254.0±25.4	27.00±1.00 / 685.8±25.4	.156 / 3.96	11300 / 50265				SRK250-1
36149	1300950263	3.00-3.49 / 76.2-88.6	22.00±2.50 / 558.8±63.5	12.00±1.00 / 304.8±25.4	28.00±1.00 / 711.2±25.4	.156 / 3.96	15100 / 67168				SRK300-1
36150	1300950264	3.50-3.99 / 88.9-101.3	25.00±2.50 / 635.0±63.5	12.00±1.00 / 304.8±25.4	31.00±1.00 / 787.4±25.4	.156 / 3.96	15100 / 67168				SRK350-1

\* TO DETERMINE RECOMMENDED WORKING LOAD, DIVIDE BREAK STRENGTH BY 5.

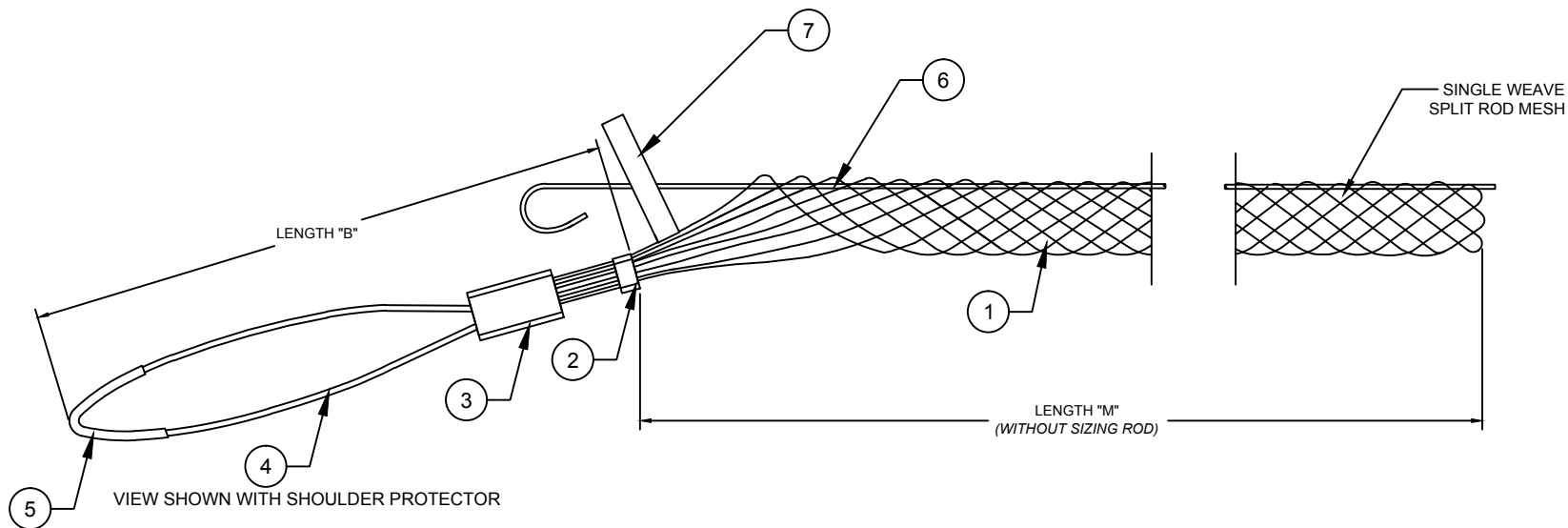

ITEM	DESCRIPTION	MATERIAL
1	WIRE MESH	GALVANIZED STEEL
2	CRIMP CONNECTOR	ALUMINUM
3	FERRULE	ALUMINUM
4	BALE WIRE	STAINLESS STEEL
5	SHOULDER PROTECTOR	ALUMINUM
6	ROD	STAINLESS STEEL
7	LABEL	MYLAR

RELEASE SALES DRAWING EC NO: IPC2015-1861 DRWN: HRUIZ01 2014/09/05 CHKD: HKNEELAN 2014/09/05 APPR: JFMURPHY 2016/09/09	DESCRIPTION REV A	QUALITY SYMBOLS $\nabla=0$ $\nabla C=0$	GENERAL TOLERANCES (UNLESS SPECIFIED)		DIMENSION STYLE INCH/MM		SCALE NTS	DESIGN UNITS INCH	THIRD ANGLE PROJECTION	
		4 PLACES ±--- ±--- 3 PLACES ±--- ±.005 2 PLACES ±.13 ±.010 1 PLACE ±.25 ±.020	mm INCH	DRAWN BY HRUIZ01	DATE 2014/09/05	TITLE <b>PULLING GRIPS          MEDIUM DUTY          SINGLE WEAVE SPLIT ROD</b>				
		ANGULAR ±1/2°		CHECKED BY HKNEELAN	DATE 2014/09/05	MOLEX INCORPORATED				
		DRAFT WHERE APPLICABLE MUST REMAIN WITHIN DIMENSIONS		APPROVED BY JFMURPHY	DATE 2016/09/09	MATERIAL NO. SEE TABLE	DOCUMENT NO. SD-130095-112	SHEET NO. 1 OF 1		

THIS DRAWING CONTAINS INFORMATION THAT IS PROPRIETARY TO MOLEX INCORPORATED AND SHOULD NOT BE USED WITHOUT WRITTEN PERMISSION