

REVISIONS				
P	LTR	DESCRIPTION	DATE	APVD
J		REVISED PER ECO-21-004775	27AUG2021	LN DM

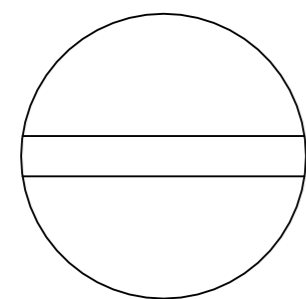

FILLISTER HEAD REF

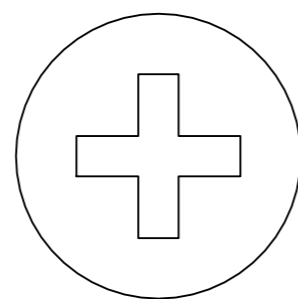

PHILLIPS HEAD REF

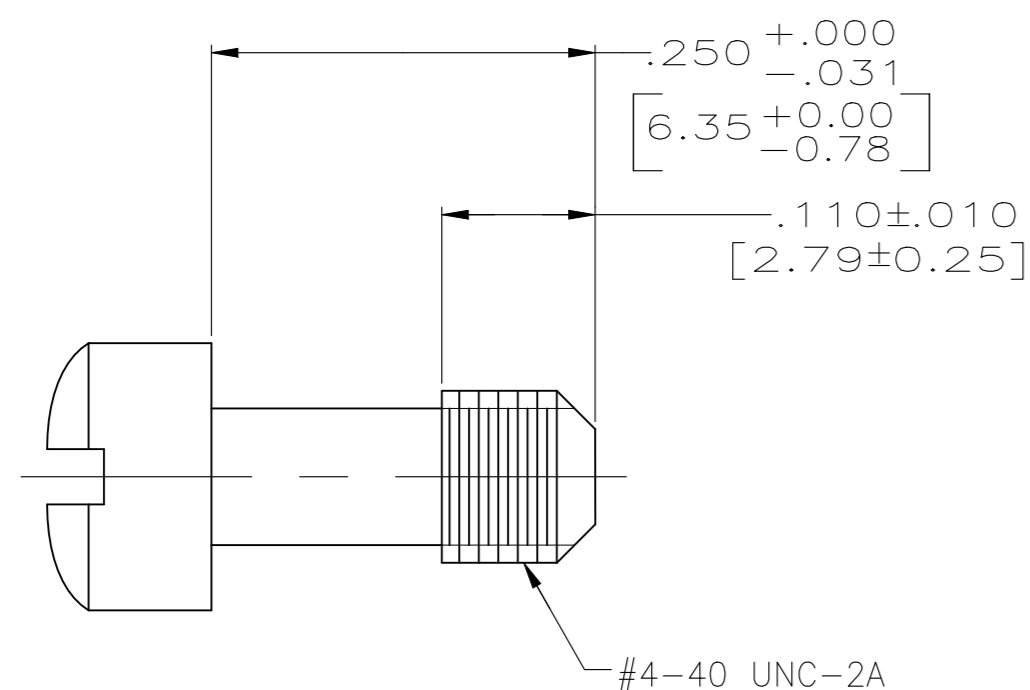
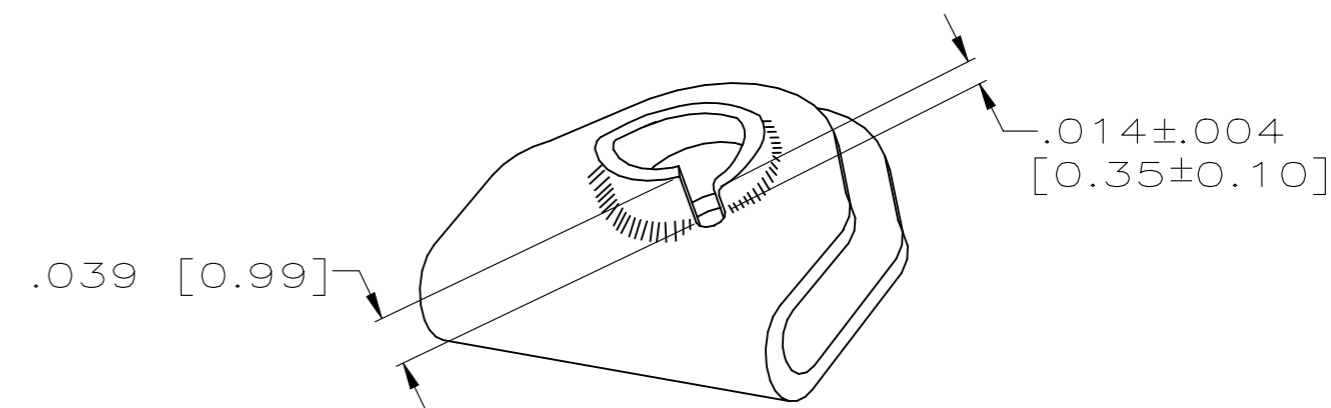

SCREW, (TYPE; SEE TABLE)
 ① OR ③
 QTY=2

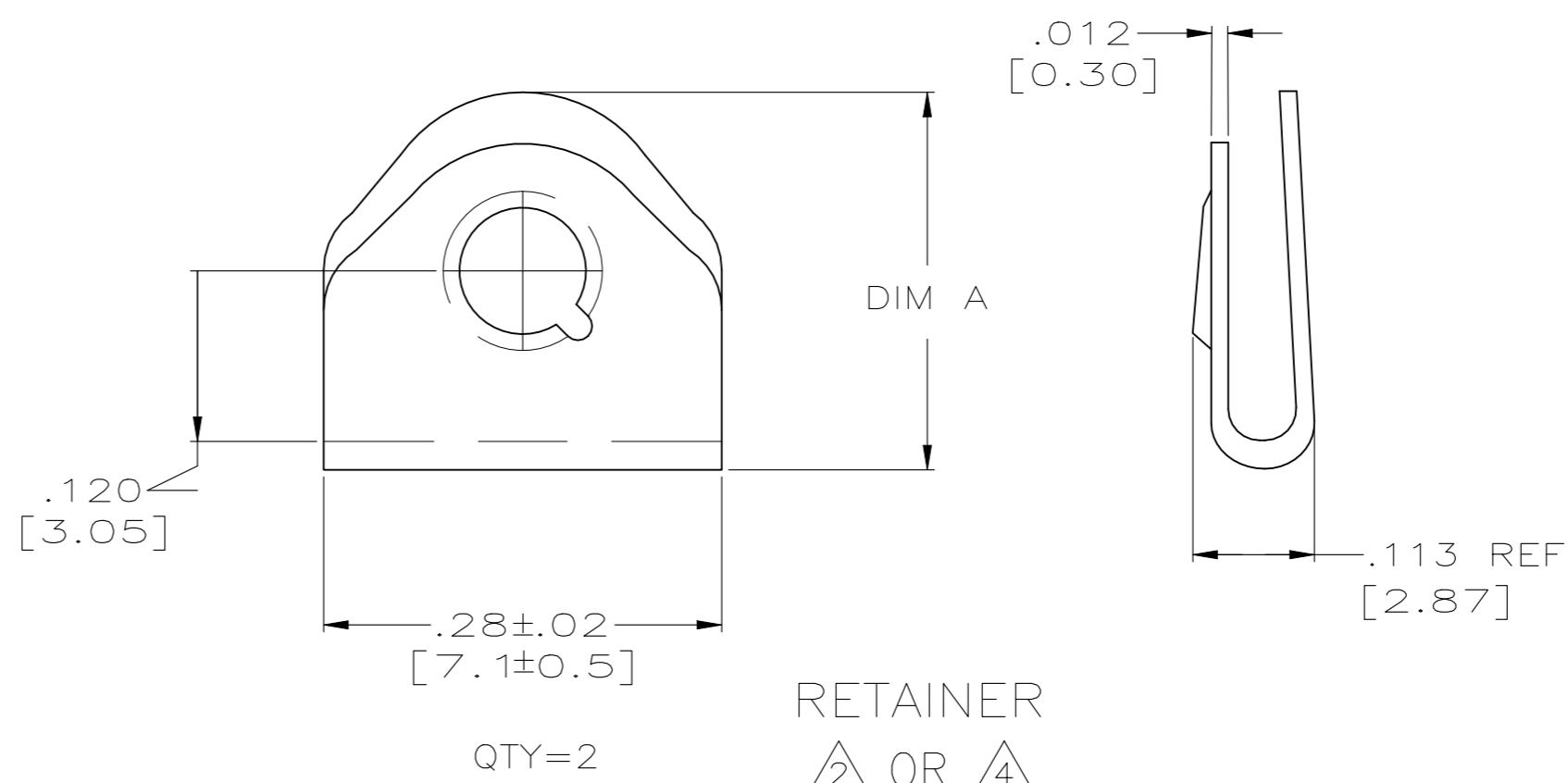

RETAINER
 ② OR ④
 QTY=2

- ① MAT'L: STAINLESS STEEL PER ASTM-A-582 OR ASTM-A-493
FINISH: PASSIVATED PER SAE-AMS-2700
 - ② MAT'L: STAINLESS STEEL PER QQ-S-766
FINISH: PASSIVATED PER SAE-AMS-2700
 - ③ MAT'L: BRASS PER ASTM-B-16
FINISH: GOLD PLATE PER ASTM-B-488
OVER COPPER PER MIL-C-14550
 - ④ MAT'L: BeCu PER QQ-C-530
FINISH: GOLD PLATE PER ASTM-B-488
OVER COPPER PER MIL-C-14550
5. PARTS ARE PACKAGED UNASSEMBLED.

PHILLIPS HEAD	.240±.010 [6.10±0.25]	-	AS SHOWN ① ②	211883-7
FILLISTER HEAD	.240±.010 [6.10±0.25]	-	AS SHOWN ① ②	211883-6
FILLISTER HEAD	.265±.015 [6.73±0.38]	M24308/25-6P	AS SHOWN ① ②	211883-5
FILLISTER HEAD	.265±.015 [6.73±0.38]	-	AS SHOWN ③ ④	211883-1
SCREW HEAD TYPE	DIM A	MILITARY PART NO	DESCRIPTION	PART NO.

THIS DRAWING IS A CONTROLLED DOCUMENT.		DWN C.C.THOMAS 2-11-03	TE TE Connectivity	
		CHK D.MILLER 2-11-03		
		APVD D.MILLER 2-11-03	NAME	
		PRODUCT SPEC	SCREW-LOCK ASSEMBLY, MALE, AMPLIMITE, KIT	
		APPLICATION SPEC		
			SIZE	RESTRICTED TO
MATERIAL SEE CALLOUTS		FINISH SEE CALLOUTS	WEIGHT 0.000000	CAGE CODE A2 00779
			DRAWING NO C=211883	
			SCALE 8:1	SHEET 1 of 1
			CUSTOMER DRAWING	REV J