

ENCODER | ENCODER

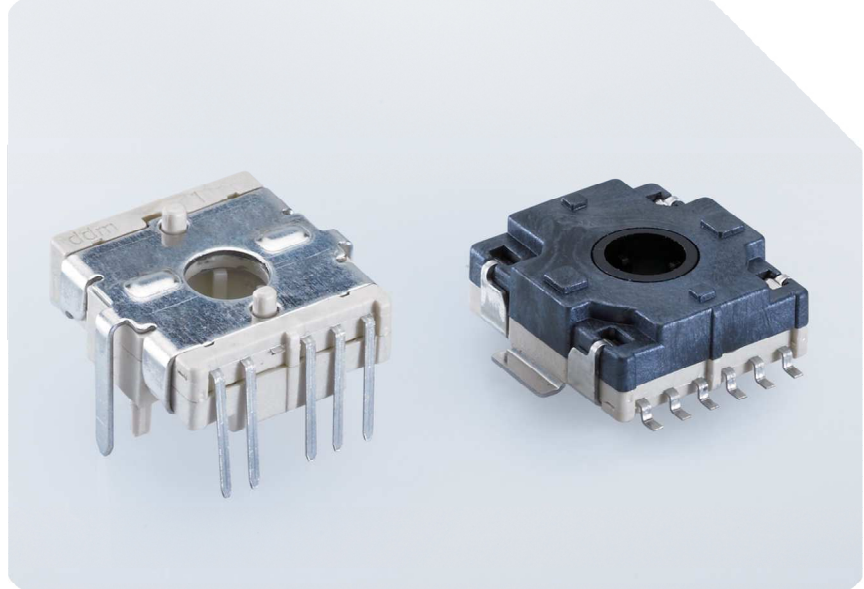

512

Ausführung

- Miniatur-Encoder mit Gray- oder Inkrementalcode
- 16 oder 18 Schaltstellungen
- Vertikale Betätigung
- Verschiedene Drehmomente
- Ohne oder mit Endschalter

Anschlüsse

SMD- oder THT-Ausführung

Abmessungen

18 x 19,5 x 7,6 mm

512

Construction

- Miniature encoder with gray or incremental code
- 16 or 18 positions
- Operated vertically
- Various torques
- Without or with end switch

Pining

SMD or THT design

Dimensions

18 x 19,5 x 7,6 mm

Ausführung Construction	Schaltweise Anschlussmaße Abmessungen	interruptive See drawings See drawings	Function Pining Outline Dimensions
Isolierwerkstoffe Insulation Material	Gehäuse Kontaktträger Blechbügel	Thermoplastic-UL-94-Vo Thermoplastic-UL-94-Vo Nirosta	Housing Contact Body metal cover
Kontaktwerkstoffe Contact Material	Festkontakte Schaltkontakte Lötanschlüsse	CuNi gal. min. 0,5 µm Au or silver as an alternative CuSn6 gal. Au flash or silver as an alternative CuNi gal. min 2 µm Sn	Fixed Contacts Sliding Contacts Pins
Elektrische Daten Electrical Data	Schaltspannung Schaltstrom max. Schaltleistung Übergangswiderstand Isolierwiderstand Prellung und Signaleinbruch	max. 24 VDC max. 100 mA 0,6 VA < 100 mOhm > 100 MOhm < 6 ms	Switching Voltage Switching Current Electrical Power Contact Resistance Insulation Resistance Bouncing
Mechanische Daten Mechanical Data	Lebensdauer Betriebstemperatur Lagertemperatur Betätigungskraft Vibrationsfestigkeit Dichtigkeit	> 10000 operations -50 °C to +125 °C -55 °C to +135 °C 1-6 Ncm / 6 N acc. to IEC 60 068-2-6:10g from 30-300 Hz IP54	Life Expectancy Operation Temperature Storage Temperature Operating Force Vibration Resistance Sealing
Lötbedingungen / Art Soldering Time / Conditions	SMD THT	acc. to IPC/JEDEC J-STD-020D Tab. 4-2 (max. peak temperature +260°) JESD22-B106D/single wave	SMD THT

Technische Änderungen vorbehalten. Modifications of technics reserved. Rev. 4 / 09.2014

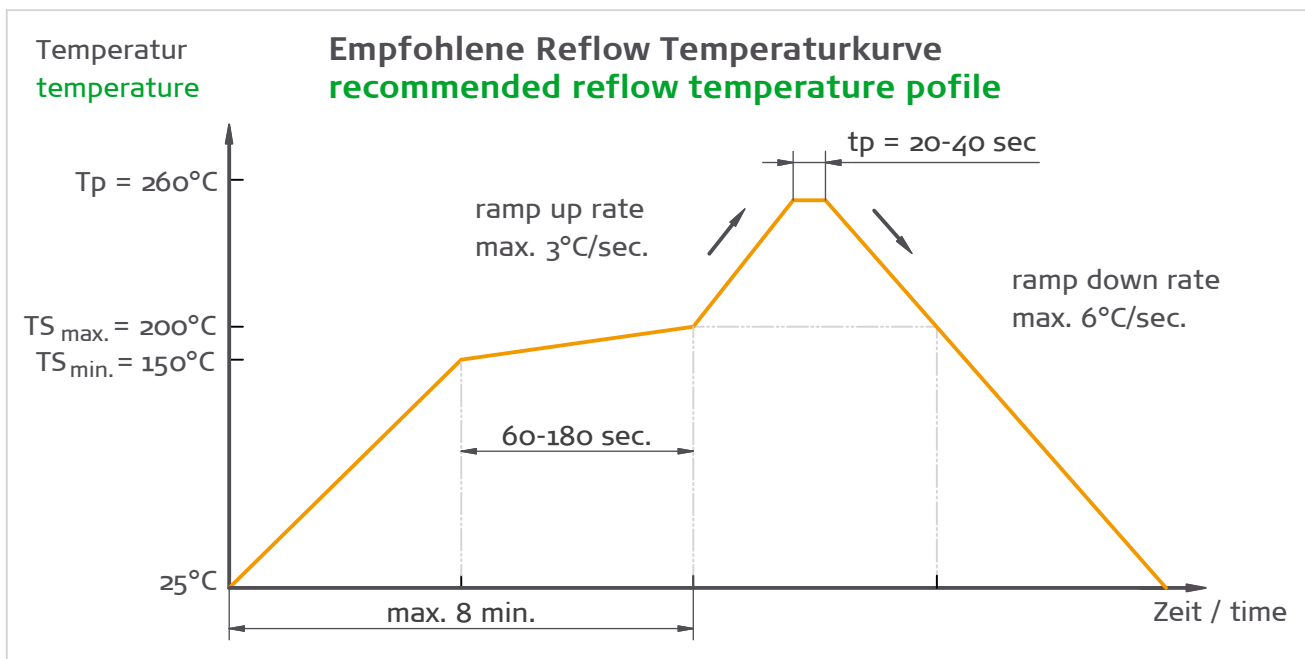



Schaltercodierung | switch coding

2Bit Inkrementalcode 16 Pos.
2Bit incremental code 16 Pos.

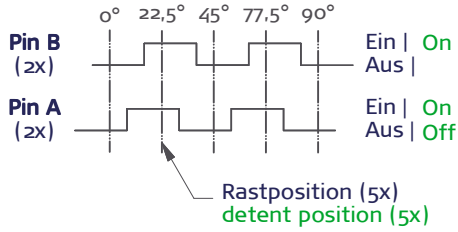

Pinbelegung
pin assignment

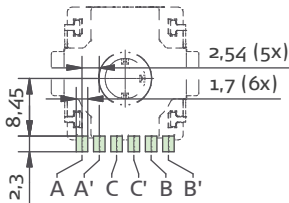

- | | | |
|---|---|--|
| 1 | 2 | Inkremental Code, 16 Pos.
incremental code, 16 Pos. |
| 7 | 5 | Graycode, 16 Positions
Graycode, 16 Positions |
| 8 | 6 | Graycode, 18 Positions
Graycode, 18 Positions |

Graycode 16 Pos.
Graycode 16 Pos.

Pos.	Spur / track			
	1	2	4	8
0				
1				
2				
3				
4				
5				
6				
7				
8				
9				
10				
11				
12				
13				
14				
15				

Pinbelegung
pin assignment

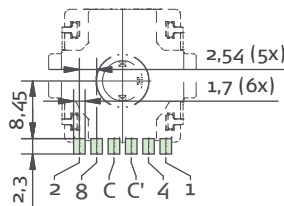

Graycode 18 Pos.
Graycode 18 Pos.

Pos.	Spur / track				
	1	2	4	8	16
0					
1					
2					
3					
4					
5					
6					
7					
8					
9					
10					
11					
12					
13					
14					
15					
16					
17					

Pinbelegung
pin assignment

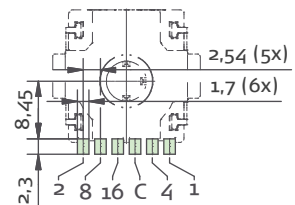

Schalterausführung | switch version

4 Vertikale Betätigung SMD
4 vertical version SMD

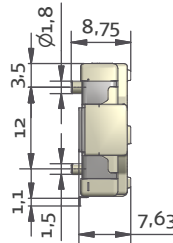
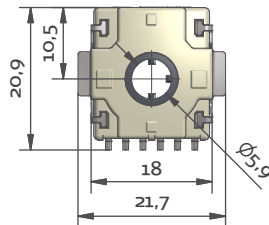
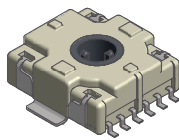

Löt-Pad-Anordnung
SMD soldering pad

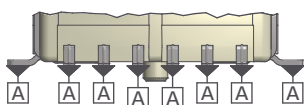
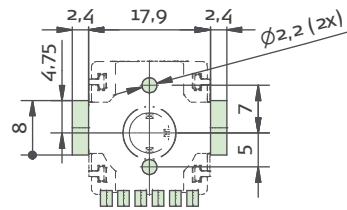

8 x A
gemeinsame Toleranzzone
common zone

	0,05	A
--	------	---



Schalterausführung | switch version

Fortsetzung | prosecution

5 Vertikal hängend DIL
vertically hanging DIL

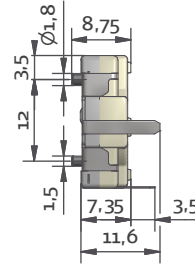
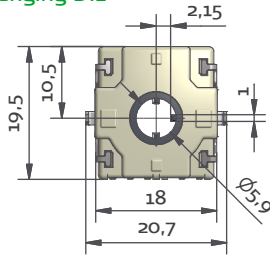
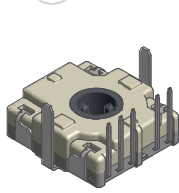

Löt-Pad-Anordnung
SMD soldering pad

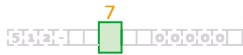
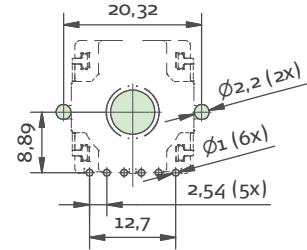

Endschalter | end-switch

0 Ohne Endschalter
without end-switch

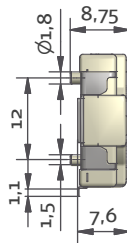
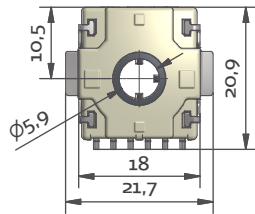
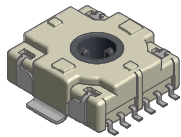

Löt-Pad-Anordnung
SMD soldering pad

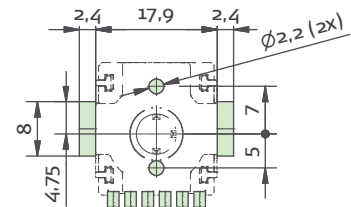

1 6N Tastkraft
6N actuating force
2 3N Tastkraft
3N actuating force

mit Endschalter, ohne durchgehende Öffnung
with end-switch, without throughout opening

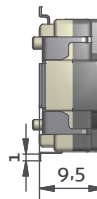
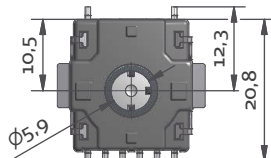
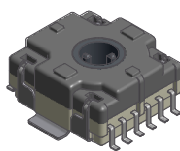

Löt-Pad-Anordnung
SMD soldering pad

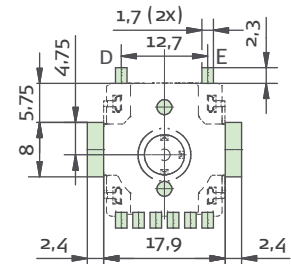

mit Endschalter, mit durchgehender Öffnung
with end-switch, with throughout opening

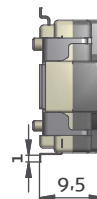
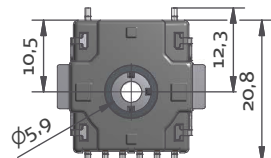
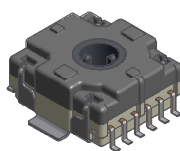

Löt-Pad-Anordnung
SMD soldering pad

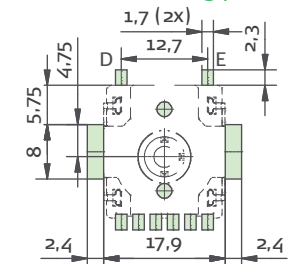

Schaltbild des Endschalters
circuit diagram of the end switch



8 Rastung | detent

- 1 Rastung 1,5 Ncm
detent 1,5 Ncm
- 2 Rastung 2,5 Ncm
detent 2,5 Ncm
- 5 Rastung 4-5 Ncm
detent 4-5 Ncm
- 6 Rastung 6 Ncm
detent 6 Ncm

9 Gehäuseausführung
housing version

- 0 Gehäuse flach | housing flat
- 1 Deckel mit Zentrierzapfen
top with centring pin

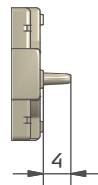
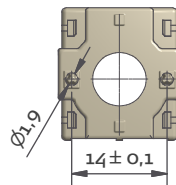
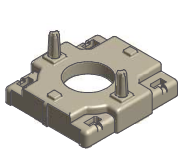
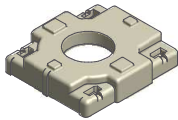

Bestell-Schlüssel
ordering code

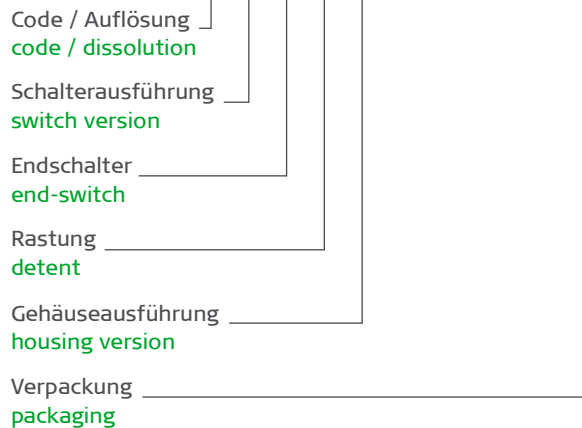

Werkstoffe Materials	Blistergurt	PS	Embossed tape
	Abdeckband	PET	Reel
Abdeckband Top Cover Tape	Zugmoment	min. 10 Nm	Embossed tape pull strength
	Abzugswinkel	165°C - 180°C	Peel of angle
	Abzugsgeschwindigkeit	300 mm / min.	Peel speed
	Abzugskraft	0.1 - 0.7 Nm	Peel force

15 Verpackung | packaging

2 Gurt (SMD) | embossed tape (SMD)

Blistergurtabmessungen
embossed tape dimensions

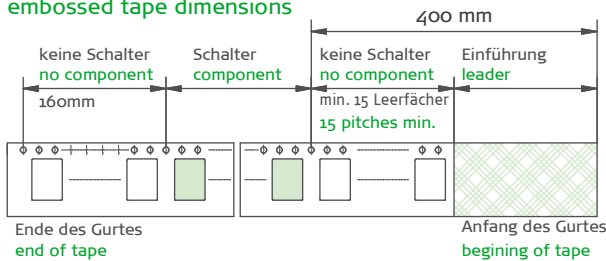

Spulenabmessungen
reel dimensions

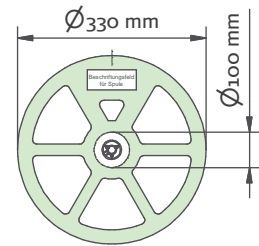

Maß "X" dimension "X"	max. Stückzahl number of pieces	Ausführung version
10,1	250	ohne Endschalter without end-switch
12	200	mit Endschalter with end-switch

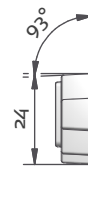
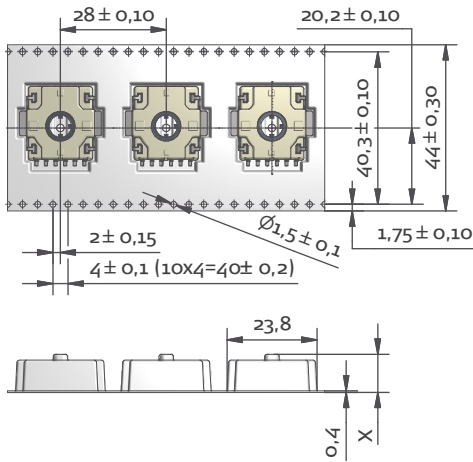

Abzugsrichtung | peel direction
Abdeckband
top cover tape

Blistergurt
carrier tape
 165°
Vorschubrichtung
direction of feed

1 Palette (THT) | palette (THT)

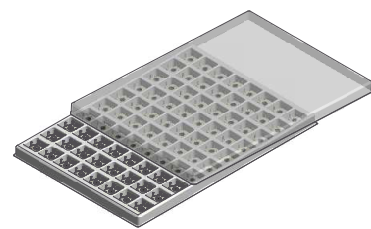
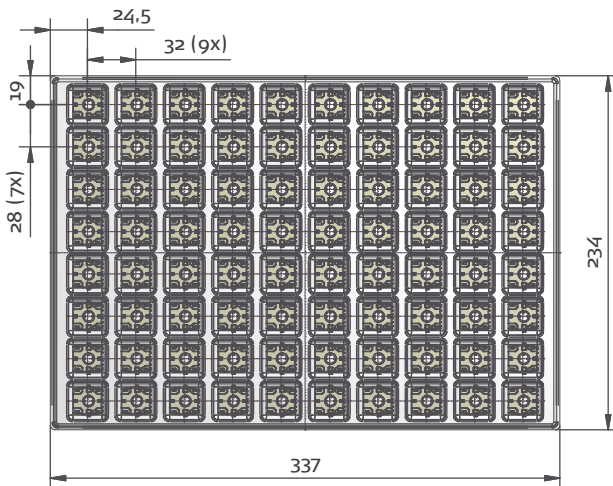

Daten der Palette
properties of the palette

max. Stückzahl number of pieces	Werkstoffe Materials
80	Palette palette PS Deckel cover PVC

Dieses Schema zeigt, wie ein Schalter 512 mit einem Mikrocontroller angeschlossen wird.

In order to minimize effect of spikes or bounds, this schema shows an example with a switch 512 connected to a micro-controller.

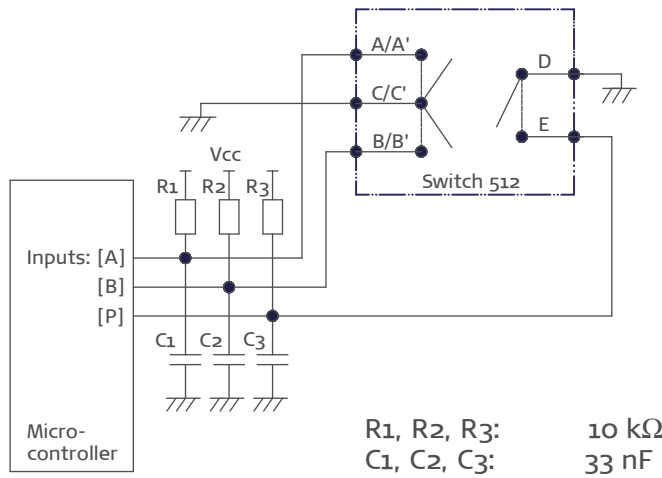

Anwendung

Dieser Algorithmus ist ein umfassendes Software Beispiel im Mikrocontroller für die Abfragung der Antriebe, die durch diesen Schalter gegeben werden.

Application notes

This algorithm is a software example to include into a micro-controller for the detection of impulses given by this switch.

CCW ← Direction → CW

Steps	N-3	N-2	N-1	N	N+1	N+2	N+3	N+4
[AB]	[10]	[11]	[01]	[00]	[10]	[11]	[01]	[00]
A xor B	1	0	1	0	1	0	1	0
[AB] _N xor [AB] _{N-1}	[10]	[01]	[10]	[01]	[10]	[01]	[10]	[01]
[AB] _{N+1} xor [AB] _N	[01]	[10]	[01]	[10]	[01]	[10]	[01]	[10]

Inputzustände:

Wir betrachten hier jeden Step wie
 wenn eine Position [AB] = [00] or [AB] = [11]
 wenn ein Übergang [AB] = [10] or [AB] = [01]

Input states:

We consider here each step as
 a position when [AB] = [00] or [AB] = [11]
 a transition when [AB] = [10] or [AB] = [01]

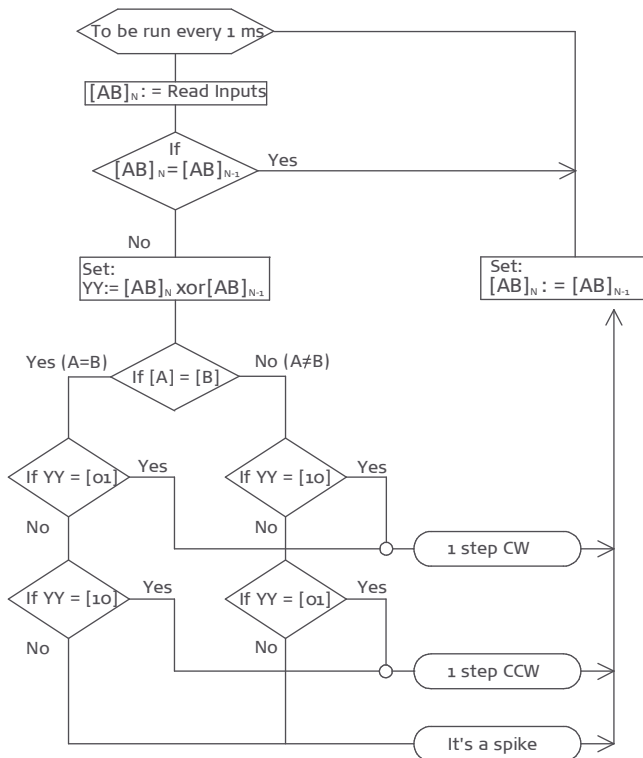

Algorithmus zum Erhalten des Stepzählimpulses und -richtung
 Algorithm to get steps count and direction:

Wenn ein Schalterpin an eine Unterbrechung Input des Mikrocontrollers angeschlossen wird und die Unterbrechung an fallender und steigender Flanke konfiguriert werden kann, sollte folgender Algorithmus einfacher einzuführen sein.

If one of the switch pin is connected to an interrupt input of the micro-controller, and the interruption can be configured at both falling and rising edge, the following algorithm should be easier to implement.

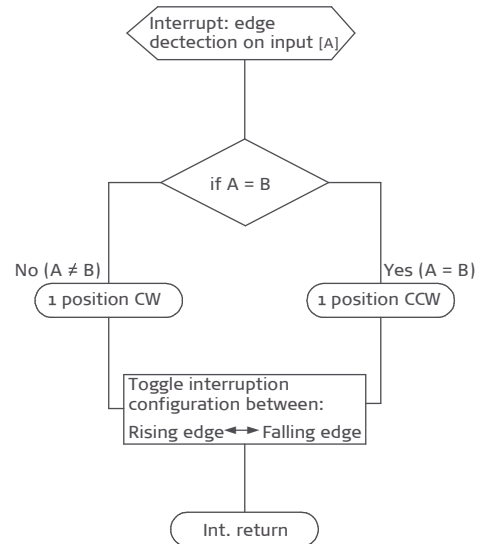

Anschrift | Address

Firma:

Company: _____

Datum:

Date: _____

Adresse:

Address: _____

Tel.:

Phone: _____

Name:

Name: _____

Fax:

Fax: _____

Kundennr.:

Customer No.: _____

E-Mail:

E-Mail: _____

Bestellschlüssel | ordering code

1	2	3	4	5	6	7	8	9	10	11	12	13	14	15
5	1	2	-						0	0	0	0	0	

Code / Auflösung
code / dissolution

Schalterausführung
switch version

Endschalter
end-switch

Rastung
detent

Gehäuseausführung
housing version

Verpackung
packaging

Notizen | Sketch

Stückzahl:

Number of pieces: _____

Versandadresse:

address for dispatch:

ddm hopt+schuler GmbH & Co. KG; Königsberger Straße 12, D-78628 Rottweil
e-Mail: ddm@hopt-schuler.com Fax: +49 741 13 398