

Click [here](#) to ask an associate for production status of specific part numbers.

MAX31343

±5ppm, I²C Real-Time Clock with Integrated MEMS Oscillator

General Description

The MAX31343 is a low-cost, extremely accurate, I²C real-time clock (RTC). The device incorporates a battery input and maintains accurate timekeeping when main power to the device is interrupted. The integration of the microelectromechanical systems (MEMS) resonator enhances the long-term accuracy of the device and eliminates the external crystal requirement in the system. The MAX31343 is available in the 8-pin WLP and TDFN packages.

The RTC maintains seconds, minutes, hours, day, date, month, year, and century information. The date at the end of the month is automatically adjusted for months with fewer than 31 days, including corrections for leap year up to year 2199. The clock operates in the 24-hour format. Other features including two programmable time-of-day alarms, interrupt output, uncompensated programmable clock output, and temperature-compensated programmable square-wave output. Address and data are transferred serially through an I²C bidirectional bus. A voltage reference and comparator circuit monitors the status of V_{CC} to detect power failures and automatically switch to the backup supply when necessary. See the Typical Application Circuit for more details.

Applications

- Industrial
- Action Cameras
- Communications
- Handheld Instrumentation
- Power Meters
- Wearables

Benefits and Features

- Highly Accurate RTC with Integrated MEMS Resonator Completely Manages All Timekeeping Functions
 - Complete Clock Calendar Functionality Including Seconds, Minutes, Hours, Day, Date, Month, Year, and Century with Leap-Year Compensation up to Year 2199
 - Timekeeping Accuracy ±5ppm (±0.432 second/day) from -40°C to +85°C
 - Two Time-of-Day Alarms
 - Temperature-Compensated Programmable Square-Wave Output
 - Uncompensated Programmable Clock Outputs
 - Automatically Switch over to Backup Battery or Supercapacitor on Power-Fail
 - Digital Temperature Sensor with ±3°C Accuracy
 - +1.6V to +5.5V Supply Voltage
- 64-Byte RAM for User Data Storage
- Simple Serial Interface Connects to Most Microcontrollers
 - I²C Interface
- Battery-Backup Input for Continuous Timekeeping
- Low-Power Operation Extends Battery-Backup Runtime
- Operating Temperature Range: -40°C to +85°C
- 2.1mm x 2.3mm, 8-Pin WLP Package
- 4mm x 3mm, 8-Pin TDFN Package
- Underwriters Laboratories® (UL) Recognized

[Ordering Information](#) appears at end of data sheet.

Underwriters Laboratories Inc. is a registered certification mark of Underwriters Laboratories Inc.

19-100717; Rev 5; 11/21

© 2021 Analog Devices, Inc. All rights reserved. Trademarks and registered trademarks are the property of their respective owners.

One Analog Way, Wilmington, MA 01887 U.S.A. | Tel: 781.329.4700 | © 2021 Analog Devices, Inc. All rights reserved.

Simplified Block Diagram

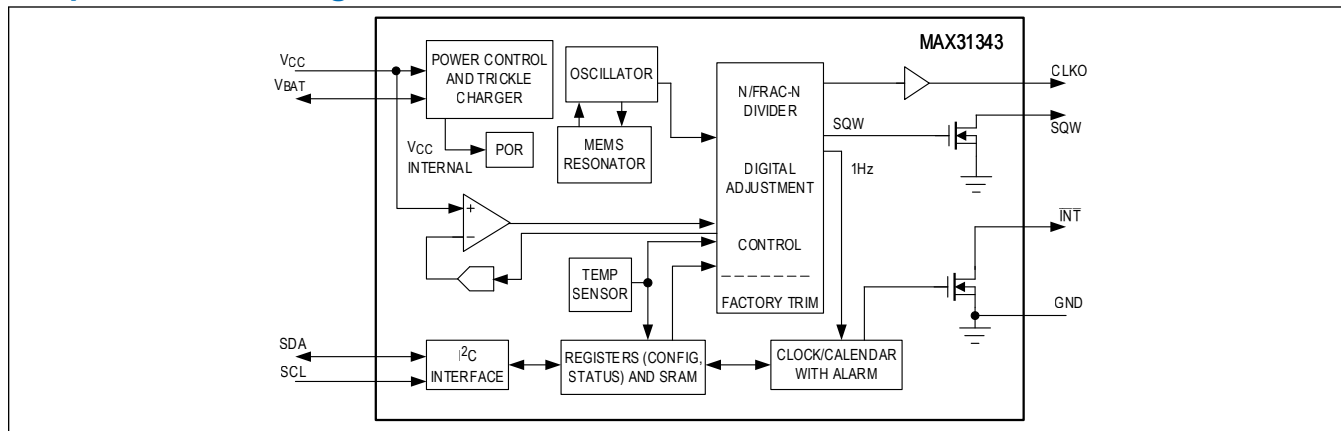

TABLE OF CONTENTS

General Description	1
Applications	1
Benefits and Features	1
Simplified Block Diagram	2
Absolute Maximum Ratings	7
Package Information	7
8 WLP	7
8 TDFN	7
Electrical Characteristics	8
Typical Operating Characteristics	11
Pin Configurations	12
8 WLP	12
8 TDFN	12
Pin Description	13
Functional Block Diagram	13
Detailed Description	14
High-Accuracy Time Base	14
Supply Operation	14
Power-Fail Interrupt Output	14
Real-Time Clock (RTC)	14
Address Map	15
RTC, Alarm, and Timer Registers	15
Clock and Calendar	16
Alarms	16
Power Management	17
Trickle Charger	18
Temperature Sensor	18
Interrupts Status and Output	18
Data-Retention Mode	18
Countdown Timer	19
Timing Diagram	19
I ² C Serial Port Operation	20
I ² C Slave Address	20
I ² C Definitions	20
I ² C Communication	22
Register Map	23
RC18 Register Map	23
Register Details	25
Applications Information	39

TABLE OF CONTENTS (CONTINUED)

Power-Supply Decoupling	39
Using Open-Drain Outputs	39
SDA and SCL Pullup Resistors	39
Handling	39
Typical Application Circuit	39
Ordering Information	39
Revision History	40

LIST OF FIGURES

Figure 1. Trickle Charger Block Diagram	18
Figure 2. I ² C Timing	19
Figure 3. I ² C Slave Address	20
Figure 4. I ² C Transactions	22

LIST OF TABLES

Table 1. Status and Configuration Registers	15
Table 2. RTC, Alarm, and Timer Registers	15
Table 3. Alarm1 Register Mask Bits	16
Table 4. Alarm2 Register Mask Bits	16
Table 5. Power Management	17
Table 6. Countdown Timer Setting	19

Absolute Maximum Ratings

Voltage Range on Any Pin Relative to GND	-0.3V to +6.0V	Junction Temperature	+150°C
Operating Temperature Range	-40°C to +85°C	Lead Temperature (soldering, 10s).....	+300°C
Storage Temperature Range.....	-55°C to +125°C	Soldering Temperature (reflow)	+260°C

Stresses beyond those listed under "Absolute Maximum Ratings" may cause permanent damage to the device. These are stress ratings only, and functional operation of the device at these or any other conditions beyond those indicated in the operational sections of the specifications is not implied. Exposure to absolute maximum rating conditions for extended periods may affect device reliability.

Package Information

8 WLP

Package Code	K82A2+1
Outline Number	21-100336
Land Pattern Number	N/A
Thermal Resistance, Four-Layer Board:	
Junction to Ambient (θ_{JA})	109.1°C/W
Junction to Case (θ_{JC})	N/A

8 TDFN

Package Code	T834MKY+1
Outline Number	21-100322
Land Pattern Number	90-100121
Thermal Resistance, Four-Layer Board:	
Junction to Ambient (θ_{JA})	47.44°C/W
Junction to Case (θ_{JC})	2.65°C/W

For the latest package outline information and land patterns (footprints), go to www.maximintegrated.com/packages. Note that a "+", "#", or "-" in the package code indicates RoHS status only. Package drawings may show a different suffix character, but the drawing pertains to the package regardless of RoHS status.

Package thermal resistances were obtained using the method described in JEDEC specification JESD51-7, using a four-layer board. For detailed information on package thermal considerations, refer to www.maximintegrated.com/thermal-tutorial.

Electrical Characteristics

(V_{CC} or V_{BAT} = +1.6V to +5.5V, T_A = -40°C to +85°C, unless otherwise noted. Typical values are at V_{CC} = +3.3V, V_{BAT} = +3.0V, and T_A = +25°C, unless otherwise noted. Limits are 100% tested at T_A = +25°C. Note 9.)

PARAMETER	SYMBOL	CONDITIONS	MIN	TYP	MAX	UNITS
RECOMMENDED OPERATING CONDITIONS (NOTE 1)						
Supply Voltage	V _{CC}		1.6	3.3	5.5	V
	V _{BAT}		1.6	3	5.5	
Logic 1	V _{IH}	V _{CC_INT} = 1.6V (Note 10)	0.75 x V _{CC_INT}		V _{CC_INT} + 0.3	V
		V _{CC_INT} = 3.3V (Note 10)	0.7 x V _{CC_INT}		V _{CC_INT} + 0.3	
Logic 0	V _{IL}	(Note 10)	-0.3		0.3 x V _{CC_INT}	V
FREQUENCY AND TIMEKEEPING						
SQW Compensated Frequency Tolerance	Δf/f _{OUT}	V _{CC} = 3.3V (Note 2)			±5	ppm
Aging Performance	Δf/f _O	Not Production Tested	0-1 Year		±1	ppm
			1-10 Years		±2	
SQW Compensated Frequency Stability vs. V _{CC} Voltage	Δf/V			±1		ppm/V
Timekeeping Accuracy	t _{KA}	V _{CC} = 3.3V (Note 2)			±0.432	Seconds/ Day
Uncompensated Output Frequency Tolerance	Δf/f _{OUT}				±1	%
DC CHARACTERISTICS / GENERAL (V_{CC} = +1.6V to +5.5V)						
Temperature Conversion Current (I ² C Inactive)	I _{CCSCONV}	V _{CC} = 3.3V		40	80	μA
		V _{CC} = 5.5V		60	100	
Power-Fail Voltage	V _{PF}	Register Pwr_mgmt[5:4] = 0x01		1.8		V
		Register Pwr_mgmt[5:4] = 0x02		2.0		
		Register Pwr_mgmt[5:4] = 0x03		2.4		
Logic 0 Output (CLKO, INT, SQW, SDA)	V _{OL}	I _{OL} = 100μA, V _{CC} = 1.6V			0.1 x V _{CC}	V
		I _{OL} = 3mA, V _{CC} = 3.3V			0.1 x V _{CC}	
Logic 1 Output (CLKO)	V _{OH}	I _{OH} = 100μA, V _{CC} = 1.6V		0.9 x V _{CC}		V
		I _{OH} = 3mA, V _{CC} = 3.3V		0.75 x V _{CC}		
Output Leakage (INT, SQW, SDA, CLKO)	I _{LO}		-0.1		0.1	μA
Input Leakage (SCL)	I _{LI}		-0.1		0.1	μA
V _{BAT} Leakage	I _{BATLKG}			3	20	nA
Temperature Accuracy	TEMP _{ACC}	V _{CC} or V _{BAT} = +3.3V		±3		°C
Temperature Conversion Time	t _{CONV}			40		ms

Electrical Characteristics (continued)

(V_{CC} or V_{BAT} = +1.6V to +5.5V, T_A = -40°C to +85°C, unless otherwise noted. Typical values are at V_{CC} = +3.3V, V_{BAT} = +3.0V, and T_A = +25°C, unless otherwise noted. Limits are 100% tested at T_A = +25°C. Note 9.)

PARAMETER	SYMBOL	CONDITIONS	MIN	TYP	MAX	UNITS
Oscillator Stop Flag (OSF) Delay	t _{OSF}	(Note 3)		20	60	ms
DC CHARACTERISTICS / CURRENT CONSUMPTION						
Timekeeping Current (I ² C Inactive) (Note 4)	I _{SUPPLY}	ENCLKO = 0; 32 second temperature measurement interval	V _{CC} = 1.6V	650	1200	nA
			V _{CC} = 3.3V	940	1500	
			V _{CC} = 5.5V	1400	2000	
Data Retention Current (Oscillator Stopped and I ² C Inactive)	I _{DR}	T _A = +25°C		5	100	nA
AC CHARACTERISTICS / POWER SWITCH (FIGURE 2)						
Maximum Supply Voltage Power-Up Slew Rate	t _{VCCR}			5		V/ms
Maximum Supply Voltage Switchover Slew Rate	t _{VCCF}			1.4		V/ms
AC CHARACTERISTICS / I²C INTERFACE (NOTE 5, FIGURE 1)						
SCL Clock Frequency	f _{SCL}				400	kHz
Bus Free Time Between STOP and START Conditions	t _{BUF}		1.3			μs
Hold Time (Repeated) START Condition	t _{HD:STA}		0.6			μs
Low Period of SCL	t _{LOW}		1.3			μs
High Period of SCL	t _{HIGH}		0.6			μs
Data Hold Time	t _{HD:DAT}		0		0.9	μs
Data Setup Time	t _{SU:DAT}		100			ns
START Setup Time	t _{SU:STA}		0.6			μs
Minimum Rise Time of Both SDA and SCL	t _{RMIN}	(Note 6)		20 + 0.1C _B		ns
Maximum Rise Time of Both SDA and SCL	t _{RMAX}			300		ns
Minimum Fall Time for Both SDA and SCL	t _{FMIN}	(Note 6)		20 + 0.1C _B		ns
Maximum Fall Time for Both SDA and SCL	t _{FMAX}			300		ns
STOP Setup Time	t _{SU:STO}		0.6			μs
Maximum Capacitive Load for Each Bus Line	C _B	(Note 7)		400		pF
SDA, SCL Input Capacitance	C _I			10		pF
Timeout Interval	t _{TIMEOUT}	(Note 8)	25		35	ms

- Note 1:** All voltages are referenced to ground.
- Note 2:** Frequency accuracy is measured over 512s interval.
- Note 3:** The parameter t_{OSF} is the period of time the oscillator must be stopped for the OSF flag to be set.
- Note 4:** Includes the temperature conversion current (averaged).
- Note 5:** Interface timing shown is for fast-mode (400kHz) operation. This device is also backward-compatible with standard mode I²C timing.
- Note 6:** Guaranteed by design; not 100% production tested.
- Note 7:** C_B : Total capacitance of one bus line in picofarads.
- Note 8:** The MAX31343 can detect any single SCL clock held low longer than $t_{TIMEOUTMIN}$. The device I²C interface is in reset state and can receive a new START condition when SCL is held low for at least $t_{TIMEOUTMAX}$. Once the device detects this condition, the SDA output is released. The oscillator must be running for this function to work.
- Note 9:** Limits at -40°C and +85°C are guaranteed by design and characterization.
- Note 10:** V_{CC_INT} is the active internal supply. $V_{CC_INT} = V_{BAT}$ when $V_{CC} < V_{PF}$ and $V_{CC} < V_{BAT}$; $V_{CC_INT} = V_{CC}$ in all other conditions in Power Management Auto mode (see [Table 5](#)).

Typical Operating Characteristics

(V_{CC} = +3.3V, V_{BAT} = +3.0V, and T_A = +25°C, unless otherwise noted.)

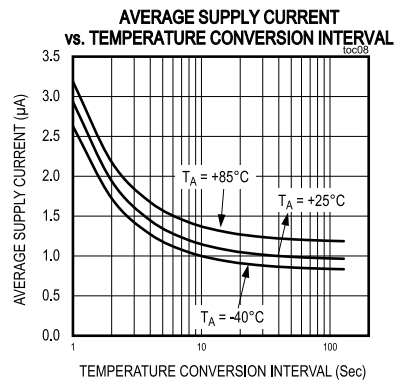
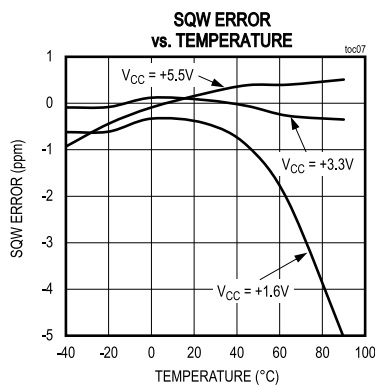
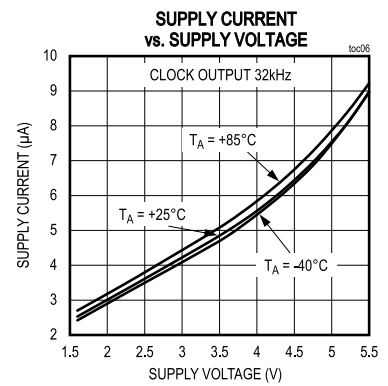
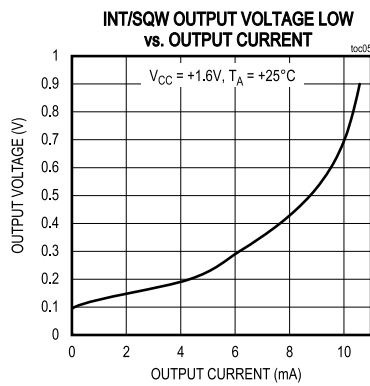
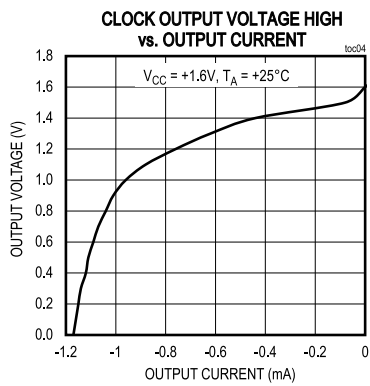
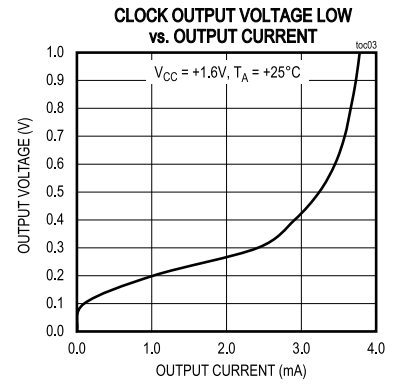
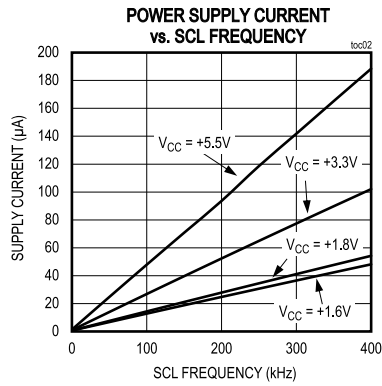
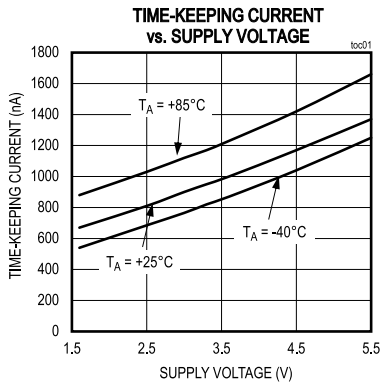

Pin Configurations

8 WLP

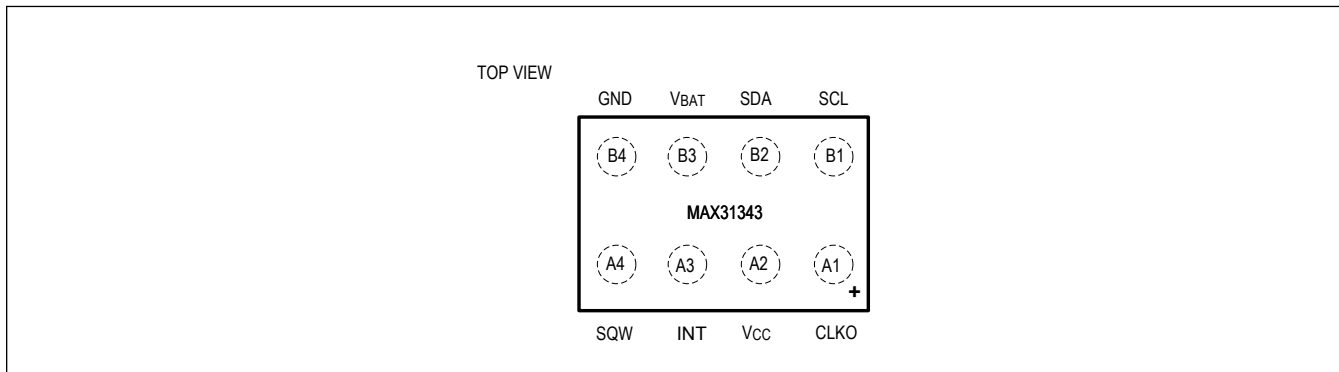

8 TDFN

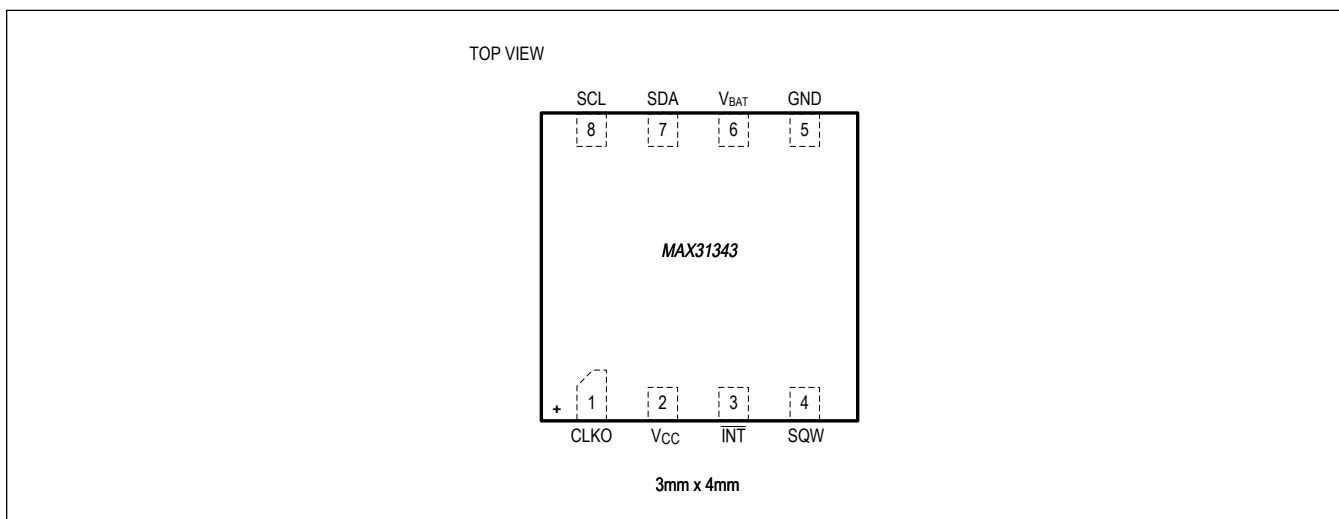

Pin Description

PIN		NAME	FUNCTION
8 WLP	8 TDFN		
A1	1	CLKO	32.875kHz or 1Hz - 128Hz CMOS Push-Pull Output (50% Duty Cycle). Enable CLKO output by setting ENCLKO bit to 1 in the RTC_config2 register (4h). This output operates on either power supply. This pin can be left open circuit if not used.
A2	2	V _{CC}	DC Power Pin for Primary Power Supply. This pin should be decoupled using a 0.1µF to 1.0µF capacitor.
A3	3	$\overline{\text{INT}}$	Active-Low Interrupt. This pin is used to output an alarm or interrupt. This is an open-drain output and requires an external pullup resistor.
A4	4	SQW	Square-Wave Output. This pin is used to output a temperature-compensated square wave with programmable frequency from 1Hz to 32Hz. This is an open-drain and requires an external pullup resistor. If not use, connect to ground.
B1	8	SCL	Serial-Clock Input. This pin is the clock input for the I ² C serial interface and is used to synchronize data movement on the serial interface. The pullup voltage can be up to 5.5V, regardless of the voltage on V _{CC} .
B2	7	SDA	Serial-Data Input/Output. This pin is the data input/output for the I ² C serial interface. This open-drain pin requires an external pullup resistor. The pullup voltage can be up to 5.5V, regardless of the voltage on V _{CC} .
B3	6	V _{BAT}	Backup Power-Supply Input. When using the device with the V _{BAT} input as the primary power source, this pin should be decoupled using a 0.1µF to 1.0µF low-leakage capacitor. When using the device with the V _{BAT} input as the backup power source, the capacitor is not required. If V _{BAT} is not used, connect to ground. The device is UL recognized to ensure against reverse charging when used with a primary lithium battery. Go to www.maximintegrated.com/qa/info/ul for more information.
B4	5	GND	Ground
—	EP	EP	Exposed Pad. Connects to ground.

Functional Block Diagram

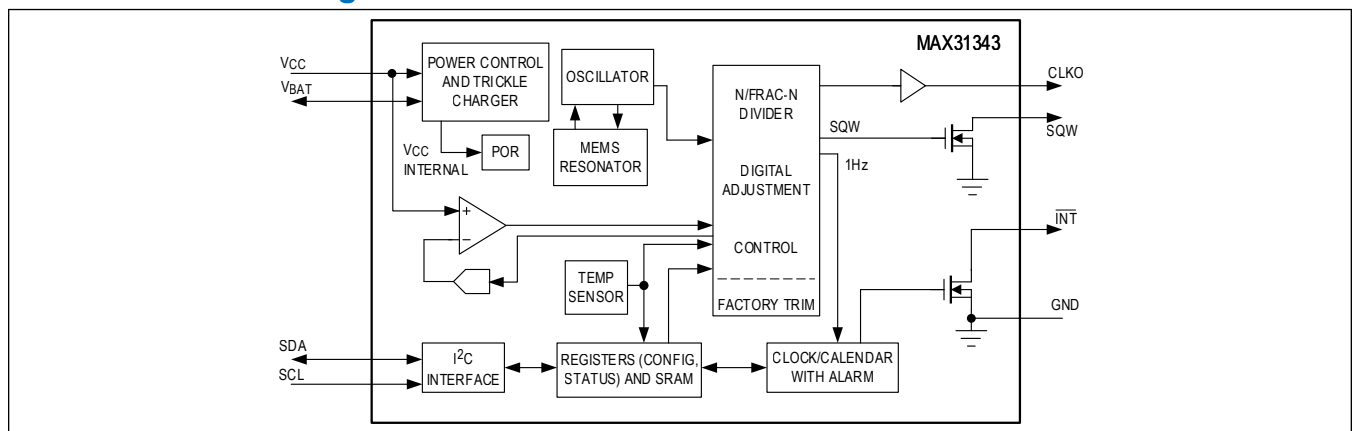

Detailed Description

The MAX31343 is a serial real-time clock (RTC) driven by an internal temperature-compensated microelectromechanical systems (MEMS) resonator. The oscillator provides a stable and accurate reference clock and maintains the RTC to within ±0.432 seconds-per-day accuracy from -40°C to +85°C. The RTC is a low-power clock/calendar with two programmable alarms. $\overline{\text{INT}}$ provides an interrupt signal due to alarm1 or alarm2 conditions. SQW outputs programmable temperature compensated square wave. Pin CLKO is an uncompensated output. The clock/calendar provides seconds, minutes, hours, day, date, month, year, and century information. The date at the end of the month is automatically adjusted for months with fewer than 31 days, including corrections for leap year up to year 2199. The clock operates in the 24-hour format. The internal registers are accessible through an I²C bus interface. An internal comparator circuit monitors the level of V_{CC} to detect power failures and to automatically switch to the backup supply when necessary.

High-Accuracy Time Base

The temperature sensor, oscillator, and digital adjustment controller logic form the highly accurate time base. The controller reads the output of the on-chip temperature sensor and adjusts the final compensated SQW output to maintain the required accuracy. The device is trimmed at the factory to maintain a tight accuracy over the operating temperature range. The device has options to manually set the rate of temperature compensation through TTSINT bits in register TS_config (0x1C), or allow the system to adjust the rate automatically.

Aging is the change in the internally compensated oscillation frequency. Unlike most crystal-based RTCs, the MAX31343 has very good aging performance. It is less than ±1ppm for zero to one year, and less than ±2ppm for one to ten years.

Supply Operation

There are several modes of operation that affect the amount of supply current that is drawn. While the serial interface is active, the active supply current is shown in the *POWER SUPPLY CURRENT vs. SCL FREQUENCY* plot. When the serial interface is inactive, the timekeeping current I_{SUPPLY} (which includes the averaged temperature-conversion current) is used. The temperature-conversion current I_{CCSCONV} is specified since the system must be able to support the periodic higher current pulse and still maintain a valid voltage level. The data-retention current I_{DR} is the current drawn by the device when major internal blocks (including oscillator) are powered down except the I²C interface (DATA_RET = 1). This mode can be used to minimize current consumption when maintaining time and date information is not necessary (e.g., while the end system is waiting to be shipped to a customer).

Power-Fail Interrupt Output

When V_{CC} falls below V_{PF}, an internal power-fail signal is generated, which forces $\overline{\text{INT}}$ low if power-fail interrupt is enabled.

Real-Time Clock (RTC)

With the 1Hz source from the temperature-compensated oscillator, the RTC provides seconds, minutes, hours, day, date, month, year, and century information. The date at the end of the month is automatically adjusted for months with fewer than 31 days, including corrections for leap year up to year 2199. The clock operates in the 24-hour format. The clock provides two programmable time-of-day alarms. $\overline{\text{INT}}$ can be enabled to generate an interrupt due to any of alarm1, alarm2, timer, temperature sense or power-fail condition. The SQW output generates a temperature-compensated square wave.

Address Map

[Table 1](#) shows the Status register and various RTC configuration registers. The Interrupt Enable (Int_en) register contains an enable bit for each of the interrupt bits. Disable Oscillator Flag (DOSF) is used to enable or disable the indication of the oscillator status through OSF flag. When an interrupt occurs, if the corresponding enable bit for that type of interrupt has been asserted, the corresponding bit in the Status register bit will be set. A read of the Status register will clear any of the flags that were set by interrupts.

Table 1. Status and Configuration Registers

ADDR	NAME	B7	B6	B5	B4	B3	B2	B1	B0	
0x00	Status	PSDECT	OSF	PFAIL		TSF	TIF	A2F	A1F	
0x01	Int_en		DOSF	PFAILE		TSIE	TIE	A2IE	A1IE	
0x02	RTC_reset								SWRST	
0x03	RTC_config1				DATARET	I2C_TIMEOUT		ENOSC	RESERVED	
0x04	RTC_config2	ENCLKO	CLKO_HZ[3:0]				SQW_HZ[2:0]			
0x05	Timer_config				TE	TPAUSE	TRPT	TFS[1:0]		

RTC, Alarm, and Timer Registers

[Table 2](#) shows the address map for the device's RTC, alarm, and timer registers. During a multibyte access, when the address pointer reaches the end of the register space (5Dh), it wraps around to location 00h. On an I²C START or address pointer incrementing to location 06h, the current time is transferred to a second set of registers. The time information is read from these secondary registers, while the clock can continue to run. This eliminates the need to reread the registers in case the main registers update during a read.

Table 2. RTC, Alarm, and Timer Registers

ADDR	NAME	B7	B6	B5	B4	B3	B2	B1	B0
0x06	Seconds		sec_10[2:0]			seconds[3:0]			
0x07	Minutes		min_10[2:0]			minutes[3:0]			
0x08	Hours			hr_10[1:0]		hour[3:0]			
0x09	Day					day[2:0]			
0x0A	Date			date_10[1:0]		date[3:0]			
0x0B	Month	century			month_10	month[3:0]			
0x0C	Year	year_10[3:0]				year[3:0]			
0x0D	Alm1_sec	A1M1	sec_10[2:0]			seconds[3:0]			
0x0E	Alm1_min	A1M2	min_10[2:0]			minutes[3:0]			
0x0F	Alm1_hrs	A1M3		hr_10[1:0]		hour[3:0]			
0x10	Alm1day_date	A1M4	DY_DT	date_10[1:0]		day_date[3:0]			
0x11	Alm1_mon	A1M5	A1M6	month_10		month[3:0]			
0x12	Alm1_year	year_10[3:0]				year[3:0]			
0x13	Alm2_min	A2M2	min_10[2:0]			minutes[3:0]			
0x14	Alm2_hrs	A2M3		hr_10[1:0]		hour[3:0]			
0x15	Alm2day_date	A2M4	DY_DT	date_10[1:0]		day_date[3:0]			
0x16	Timer_count	count[7:0]							
0x17	Time_init	count[7:0]							

Clock and Calendar

The time and calendar information is obtained by reading the appropriate register bytes. [Table 2](#) shows the RTC registers. The time and calendar data are set or initialized by writing the appropriate register bytes. Time will be updated 1 second after user sets the timer registers. The contents of the time and calendar registers are in the binary-coded decimal (BCD) format. The device runs in 24-hour mode.

The century bit (bit 7 of the Month register) is toggled when the Years register overflows from 99 to 00. The day-of-week register increments at midnight. Values that correspond to the day of week are user-defined but must be sequential (i.e., if 1 equals Sunday, then 2 equals Monday, and so on). Illogical time and date entries result in undefined operation. When reading or writing the time and date registers, secondary buffers are used to prevent errors when the internal registers update. When reading the time and date registers, the secondary buffers are synchronized to the internal registers on any I²C START and when the register pointer rolls over to zero. The time information is read from these secondary registers, while the clock continues to run. This eliminates the need to reread the registers in case the main registers update during a read.

Alarms

The device contains two time-of-day/date alarms. Alarm 1 can be set by writing to registers 0Dh–12h. Alarm 2 can be set by writing to registers 13h–15h. See [Table 3](#) and [Table 4](#). The alarms can be programmed by the A1IE and A2IE bits in Int_en register to activate the INT output on an alarm match condition. Bit 7 of each of the time-of-day/date alarm registers and bit 6 of Alm1_mon register are mask bits ([Table 3](#)). When all the mask bits for each alarm are logic 0, an alarm only occurs when the values in the timekeeping registers match the corresponding values stored in the time-of-day, date, month, and year alarm registers. The alarms can also be programmed to repeat every second, minute, hour, day, or date. [Table 3](#) and [Table 4](#) show the possible settings. Configurations not listed in the table result in illogical operation. The DY_DT bit (bit 6 of the alarm day/date registers) controls whether the alarm value stored in bits 0–5 of that register represents the day of the week or the date of the month. If DY_DT is written to logic 0, the alarm is the result of a match with date of the month. If DY_DT is written to logic 1, the alarm is the result of a match with day of the week. Disable alarms before programming alarm registers, then enable them 1 second after alarm configured.

Table 3. Alarm1 Register Mask Bits

DY/DT	ALARM 1 REGISTER MASK BITS						ALARM RATE
	A1M6	A1M5	A1M4	A1M3	A1M2	A1M1	
X	1	1	1	1	1	1	Alarm once a second
X	1	1	1	1	1	0	Alarm when seconds match
X	1	1	1	1	0	0	Alarm when minutes and seconds match
X	1	1	1	0	0	0	Alarm when hours, minutes, and seconds match
0	1	1	0	0	0	0	Alarm when dates, hours, minutes, and seconds match
0	1	0	0	0	0	0	Alarm when months, dates, hours, minutes, and seconds match
0	0	0	0	0	0	0	Alarm when years, months, dates, hours, minutes, and seconds match
1	1	1	0	0	0	0	Alarm when days, hours, minutes, and seconds match

Table 4. Alarm2 Register Mask Bits

DY/DT	ALARM 2 REGISTER MASK BITS			ALARM RATE
	A2M4	A2M3	A2M2	
				Alarm once per minute (00 seconds of every minute)
X	1	1	1	Alarm when minutes match
X	1	1	0	Alarm when hours and minutes match
X	1	0	0	Alarm when dates, hours, and minutes match
0	0	0	0	Alarm when days, hours, and minutes match
1	0	0	0	Alarm when days, hours, and minutes match

Power Management

The MAX31343 power management has two modes, auto and manual. Power management auto mode monitors supply voltage on V_{CC} and backup battery voltage on V_{BAT} , and then determines which source to use as internal supply. There is a PFAIL interrupt flag status bit in the register map to indicate the power-fail condition. Pin V_{BAT} should be connected to the backup battery. If there is no backup battery, V_{BAT} should be tied to ground. Although backup battery can drive the RTC, the V_{CC} supply must be applied to power up the RTC. Power management control bits Pwr_mgmt[3:2] (register 0x18h) are used as follows.

For the Power Management Auto and Trickle Charger mode, specify a “power-fail voltage” with the register Pwr_mgmt[5:4]. Pwr_mgmt[5:4] = 01b sets the power-fail voltage to V_{PF2} . Pwr_mgmt[5:4] = 10b sets the power-fail voltage to V_{PF3} . Pwr_mgmt[5:4] = 11b sets the power-fail voltage to V_{PF4} . See the values of V_{PF2} , V_{PF3} , and V_{PF4} in the [Electrical Characteristics](#) table. Note that Pwr_mgmt[5:4] = 00b, V_{PF1} is not a valid power-fail voltage. Once the power-fail voltage is set, MAX31343 will switch backup battery to the internal power supply if and only if main supply V_{CC} is lower than both the power-fail voltage and the backup battery voltage. Otherwise, V_{CC} remains as the main supply.

The PFAIL interrupt flag status bit in the status register (00h) is used as the power-fail flag. In power management auto mode, PFAIL interrupt flag monitors the V_{CC} supply and is set when V_{CC} falls below the power-fail threshold voltage set through PFVT in the Pwr_mgmt (18h) register or when power-fail threshold voltage is adjusted to cross above V_{CC} .

Table 5. Power Management

TCHE[7:4]	D_VBACK_SEL	D_MAN_SEL	MODE OF OPERATION	
0x5	x	0	Power Management Auto and Trickle Charger On	
			Supply Condition	Active Supply
			$V_{CC} < V_{PF}$, $V_{CC} < V_{BAT}$	V_{BAT}
			$V_{CC} < V_{PF}$, $V_{CC} > V_{BAT}$	V_{CC}
			$V_{CC} > V_{PF}$, $V_{CC} < V_{BAT}$	V_{CC}
			$V_{CC} > V_{PF}$, $V_{CC} > V_{BAT}$	V_{CC}
0x5	0	1	Power Management Manual and Trickle Charger On Active Supply = V_{CC}	
0x5	1	1	Power Management Manual and Trickle Charger On Active Supply = V_{BAT} for $V_{BAT} \geq V_{CC}$	
Other than 0x5	x	0	Power Management Auto and Trickle Charger Off	
			Supply Condition	Active Supply
			$V_{CC} < V_{PF}$, $V_{CC} < V_{BAT}$	V_{BAT}
			$V_{CC} < V_{PF}$, $V_{CC} > V_{BAT}$	V_{CC}
			$V_{CC} > V_{PF}$, $V_{CC} < V_{BAT}$	V_{CC}
			$V_{CC} > V_{PF}$, $V_{CC} > V_{BAT}$	V_{CC}
Other than 0x5	0	1	Power Management Manual and Trickle Charger Off Active Supply = V_{CC}	
Other than 0x5	1	1	Power Management Manual and Trickle Charger Off Active Supply = V_{BAT} for $V_{BAT} \geq V_{CC}$	

Trickle Charger

The trickle charger is for charging an external supercapacitor or a rechargeable battery. The maximum charging current can be calculated as follows:

$$I_{MAX} = (V_{CC} - V_D - V_{BAT}) / R$$

Where V_D is the diode voltage drop, V_{BAT} is the voltage of the battery being charged, and R is the resistance selected in the charging path.

As the battery charges, the battery voltage increases and the voltage across the charging path decreases. Therefore, the charging current also decreases.

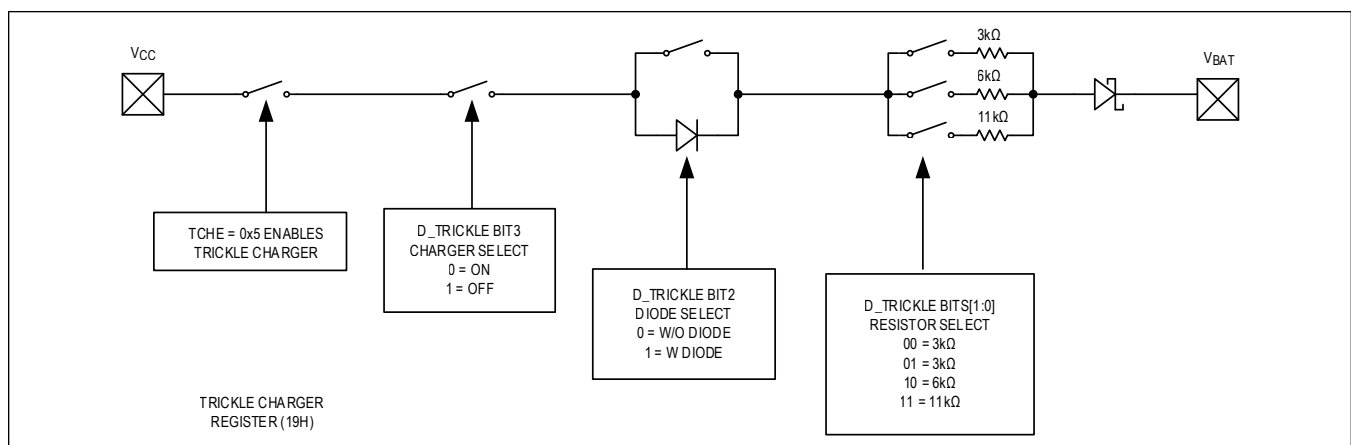

Figure 1. Trickle Charger Block Diagram

Temperature Sensor

The MAX31343 has on-chip temperature sensor for MEMS oscillator output frequency temperature compensation. When temperature measurement is made, the fractional divider divide ratio will be updated to correct the RTC time base frequency. There are two ways to enable the temperature conversion. When AUTOMODE bit (TS_Config[7]) is set to 1, temperature sensor performs conversion automatically at the rate selected in TTSINT bit field (TS_Config[5:3]). When AUTOMODE bit is 0, writing 1 to ONESHOTMODE register bit (TS_Config[6]) enables single temperature conversion mode. ONESHOTMODE bit clears automatically after about 70ms when temperature conversion is complete. Temperature data is stored in Temp_MSB and Temp_LSB registers.

Interrupts Status and Output

When an interrupt is asserted, a corresponding status bit in Status (00h) becomes "1", and an interrupt output transitions from high to low. The Interrupt status bit and output can be cleared by reading the Status reg.

Data-Retention Mode

The MAX31343 features a data-retention mode wherein the device shuts down its internal functional blocks (including the oscillator) except the I²C interface. The device consumes 100nA maximum in this mode. It retains all of the register and RAM contents, including the last valid date and time values. Exit data-retention mode to resume counting. User data can be preserved in the RAM in this mode as long as the active supply is present. To enter data-retention mode, write "1" to DATA_RET in the RTC_config1(03h) register. To exit data-retention mode, write "0" to DATA_RET in the RTC_config1(03h) register. In data-retention mode, the device will automatically return back to use the external supply (V_{CC}) as its active supply, regardless of the power-management mode.

Countdown Timer

The MAX31343 features a countdown timer with a pause function. The timer can be configured by writing into registers Timer_config (05h) and Timer_init (17h). The Timer_init register should be loaded with the initial value from which the timer would start counting down. The Timer_config register allows these configuration options:

- Select the frequency of the timer using the TFS[1:0] field.
- Start/stop the timer using the TE (Timer Enable) bit.
- Enable/disable the timer repeat function using the TRPT bit. This function reloads and restarts the timer with the same init value once it counts down to zero.
- Pause/resume the countdown at any time when the timer is enabled using the TPAUSE bit (explained below).

The timer can be programmed to assert the $\overline{\text{INT}}$ output (see Table 6) whenever it counts down to zero. This can be enabled/disabled using the TIE bit in register Int_en register (01h).

The TPAUSE bit is only valid when TE = 1. This bit must be reset to 0 whenever TE is reset to 0.

Table 6 highlights the steps to be used for various use cases involving TE and TPAUSE.

Typical use cases:

- Countdown timer without pause: Step 1 -> Step 2 -> Step 1 and so on
- Countdown timer with pause: Step 1 -> Step 2 -> Step 3a -> Step 3b -> Step 1 and so on

Table 6. Countdown Timer Setting

SEQUENCE	TE	TPAUSE	ACTION
Step 1	0	0	Countdown timer is reset, and ready for next countdown operation. Timer_init can be programmed in this state.
Step 2	1	0	Countdown timer starts counting down from the value programmed in Timer_init
Step 3a (Optional)	1	1	Countdown timer is paused, and is ready to start counting down when TPAUSE is programmed back to '0'. Contents of the countdown timer are preserved in this state.
Step 3b If 3a is true	1	0	Countdown timer is brought out of pause state, and starts counting down from the paused value.
	0	1	Not allowed

Timing Diagram

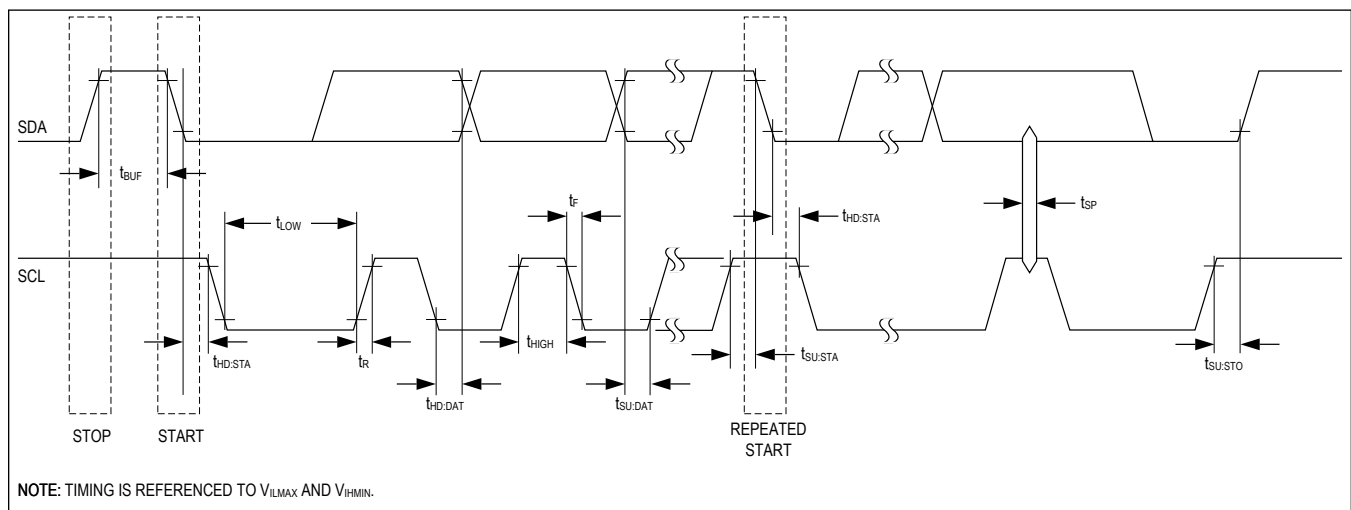

Figure 2. I²C Timing

I²C Serial Port Operation

I²C Slave Address

The device's slave address byte is D0h. The first byte sent to the device includes the device identifier, device address, and the R/W bit (Figure 3). The device address sent by the I²C master must match the address assigned to the device.

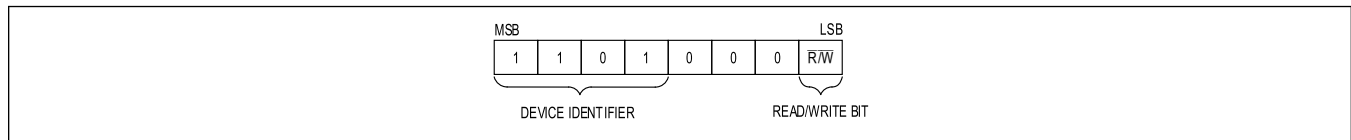

Figure 3. I²C Slave Address

I²C Definitions

The following terminology is commonly used to describe I²C data transfers.

Master Device: The master device controls the slave devices on the bus. The master device generates SCL clock pulses and START and STOP conditions.

Slave Devices: Slave devices send and receive data at the master's request.

Bus Idle or Not Busy: Time between STOP and START conditions when both SDA and SCL are inactive and in their logic-high states. When the bus is idle, it often initiates a low-power mode for slave devices.

START Condition: A START condition is generated by the master to initiate a new data transfer with a slave. Transitioning SDA from high to low while SCL remains high generates a START condition. See [[I2C Timing]] for applicable timing.

STOP Condition: A STOP condition is generated by the master to end a data transfer with a slave. Transitioning SDA from low to high while SCL remains high generates a STOP condition. See [[I2C Timing]] for applicable timing.

Repeated START Condition: The master can use a repeated START condition at the end of one data transfer to indicate that it immediately initiates a new data transfer following the current one. Repeated STARTs are commonly used during read operations to identify a specific memory address to begin a data transfer. A repeated START condition is issued identically to a normal START condition. See [[I2C Timing]] for applicable timing.

Bit Write: Transitions of SDA must occur during the low state of SCL. The data on SDA must remain valid and unchanged during the entire high pulse of SCL plus the setup and hold time requirements (see [[I2C Timing]]). Data is shifted into the device during the rising edge of the SCL.

Bit Read: At the end of a write operation, the master must release the SDA bus line for the proper amount of setup time (see [[I²C Timing]]) before the next rising edge of SCL during a bit read. The device shifts out each bit of data on SDA at the falling edge of the previous SCL pulse and the data bit is valid at the rising edge of the current SCL pulse. Remember that the master generates all SCL clock pulses including when it is reading bits from the slave.

Acknowledge (ACK and NACK): An acknowledge (ACK) or not acknowledge (NACK) is always the ninth bit transmitted during a byte transfer. The device receiving data (the master during a read or the slave during a write operation) performs an ACK by transmitting a 0 during the ninth bit. A device performs a NACK by transmitting a 1 during the ninth bit. Timing for the ACK and NACK is identical to all other bit writes. An ACK is the acknowledgment that the device is properly receiving data. A NACK is used to terminate a read sequence or as an indication that the device is not receiving data.

Byte Write: A byte write consists of 8 bits of information transferred from the master to the slave (most significant bit first) plus a 1-bit acknowledgment from the slave to the master. The 8 bits transmitted by the master are done according to the bit write definition and the acknowledgment is read using the bit read definition.

Byte Read: A byte read is an 8-bit information transfer from the slave to the master plus a 1-bit ACK or NACK from the master to the slave. The 8 bits of information that are transferred (most significant bit first) from the slave to the master are read by the master using the bit read definition, and the master transmits an ACK using the bit write definition to receive additional data bytes. The master must NACK the last byte read to terminate communication so the slave returns control of SDA to the master.

Slave Address Byte: Each slave on the I²C bus responds to a slave address byte sent immediately following a START condition. The slave address byte contains the slave address in the most significant 7 bits and the R/W bit in the least significant bit. The device's slave address is D0h and cannot be modified by the user. When the R/W bit is 0 (such as in D0h), the master is indicating it writes data to the slave. If R/W = 1 (D1h in this case), the master is indicating it wants to read from the slave. If an incorrect slave address is written, the device assumes the master is communicating with another I²C device and ignore the communication until the next START condition is sent.

Memory Address: During an I²C write operation, the master must transmit a memory address to identify the memory location where the slave is to store the data. The memory address is always the second byte transmitted during a write operation following the slave address byte.

I²C Communication

See [Figure 4](#) for an I²C communication example.

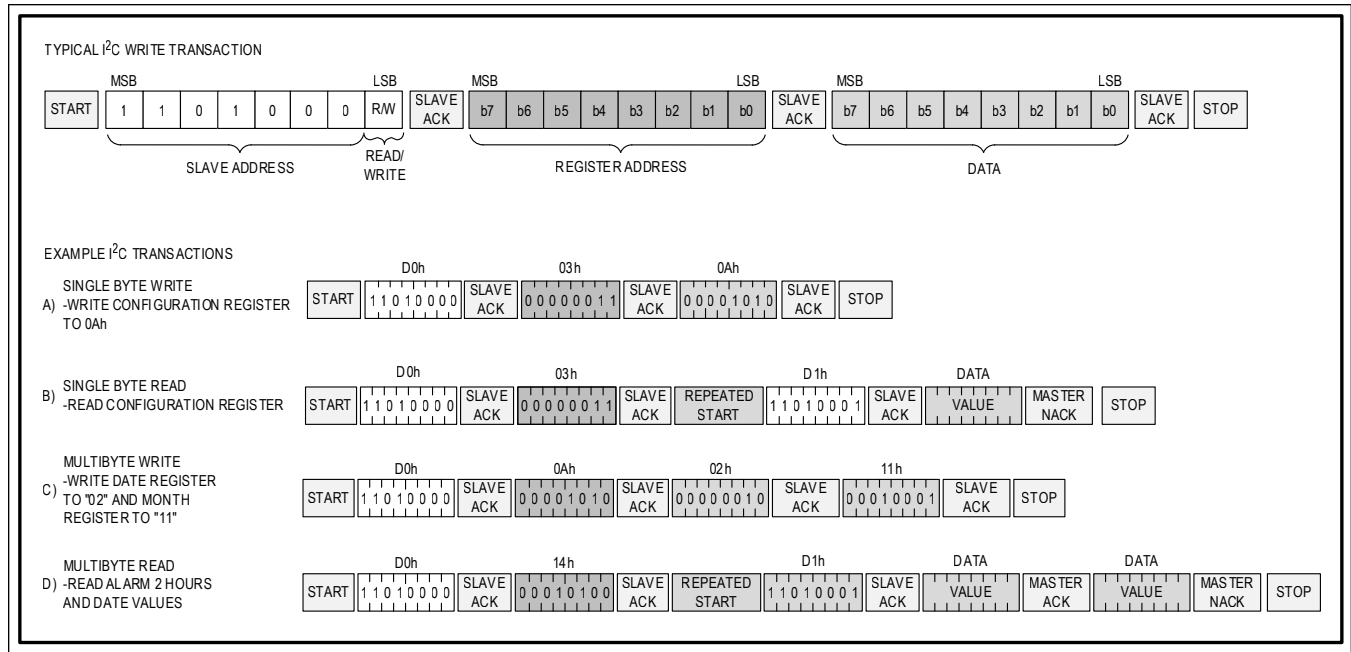

Figure 4. I²C Transactions

Writing a Single Byte to a Slave: The master must generate a START condition, write the slave address byte (R/W = 0), write the memory address, write the byte of data, and generate a STOP condition. Remember the master must read the slave's acknowledgment during all byte write operations.

Writing Multiple Bytes to a Slave: To write multiple bytes to a slave, the master generates a START condition, writes the slave address byte (R/W = 0), writes the starting memory address, writes multiple data bytes, and generates a STOP condition.

Reading a Single Byte from a Slave: Unlike the write operation that uses the specified memory address byte to define where the data is to be written, the read operation occurs at the present value of the memory address counter. To read a single byte from the slave, the master generates a START condition, writes the slave address byte with R/W = 1, reads the data byte with a NACK to indicate the end of the transfer, and generates a STOP condition. However, since requiring the master to keep track of the memory address counter is impractical, use the method for manipulating the address counter for reads.

Manipulating the Address Counter for Reads: A dummy write cycle can be used to force the address counter to a particular value. To do this the master generates a START condition, writes the slave address byte (R/W = 0), writes the memory address where it desires to read, generates a repeated START condition, writes the slave address byte (R/W = 1), reads data with ACK or NACK as applicable, and generates a STOP condition. See [Figure 4](#) for a read example using the repeated START condition to specify the starting memory location.

Reading Multiple Bytes from a Slave: The read operation can be used to read multiple bytes with a single transfer. When reading bytes from the slave, the master simply ACKs the data byte if it desires to read another byte before terminating the transaction. After the master reads the last byte it must NACK to indicate the end of the transfer and then it generates a STOP condition.

Register Map

RC18 Register Map

ADDRESS	NAME	MSB							LSB
REGBLK									
0x00	Status[7:0]	PSDECT	OSF	PFAIL	–	TSF	TIF	A2F	A1F
0x01	Int_en[7:0]	–	DOSF	PFAILE	–	TSIE	TIE	A2IE	A1IE
0x02	RTC_reset[7:0]	–	–	–	–	–	–	–	SWRST
0x03	RTC_config1[7:0]	–	–	–	DATA_R ET	I2C_TIM EOUT	–	ENOSC	RESERV ED
0x04	RTC_config2[7:0]	ENCLKO	CLKO_HZ[3:0]			SQW_HZ[2:0]			
0x05	Timer_config[7:0]	–	–	–	TE	TPAUSE	TRPT	TFS[1:0]	
0x06	Seconds[7:0]	–	sec_10[2:0]			seconds[3:0]			
0x07	Minutes[7:0]	–	min_10[2:0]			minutes[3:0]			
0x08	Hours[7:0]	–	–	hr_10[1:0]		hour[3:0]			
0x09	Day[7:0]	–	–	–	–	–	day[2:0]		
0x0A	Date[7:0]	–	–	date_10[1:0]		date[3:0]			
0x0B	Month[7:0]	century	–	–	month_1 0	month[3:0]			
0x0C	Year[7:0]	year_10[3:0]			year[3:0]				
0x0D	Alm1_sec[7:0]	A1M1	sec_10[2:0]			seconds[3:0]			
0x0E	Alm1_min[7:0]	A1M2	min_10[2:0]			minutes[3:0]			
0x0F	Alm1_hrs[7:0]	A1M3	–	hr_10[1:0]		hour[3:0]			
0x10	Alm1day_date[7:0]	A1M4	DY_DT	date_10[1:0]		day_date[3:0]			
0x11	Alm1_mon[7:0]	A1M5	A1M6	–	month_1 0	month[3:0]			
0x12	Alm1_year[7:0]	year_10[3:0]			year[3:0]				
0x13	Alm2_min[7:0]	A2M2	min_10[2:0]			minutes[3:0]			
0x14	Alm2_hrs[7:0]	A2M3	–	hr_10[1:0]		hour[3:0]			
0x15	Alm2day_date[7:0]	A2M4	DY_DT	date_10[1:0]		day_date[3:0]			
0x16	Timer_Count[7:0]	Count[7:0]							
0x17	Timer_Init[7:0]	Count[7:0]							
0x18	Pwr_mgmt[7:0]	–	–	PFVLT[1:0]		D_VBAC K_SEL	D_MAN_ SEL	–	–
0x19	Trickle_reg[7:0]	TCHE[3:0]				D_TRICKLE[3:0]			
0x1A	Temp_MSB[7:0]	Temperature[15:8]							
0x1B	Temp_LSB[7:0]	Temperature[7:0]							
0x1C	TS_config[7:0]	AUTOM ODE	ONESH OTMOD E	TTSINT[2:0]			–	–	–
RAM_REG									
0x22	Ram_reg 0[7:0]	Data[7:0]							
0x23	Ram_reg 1[7:0]	Data[7:0]							
0x24	Ram_reg 2[7:0]	Data[7:0]							

ADDRESS	NAME	MSB						LSB
0x25	Ram_reg 3[7:0]							Data[7:0]
0x26	Ram_reg 4[7:0]							Data[7:0]
0x27	Ram_reg 5[7:0]							Data[7:0]
0x28	Ram_reg 6[7:0]							Data[7:0]
0x29	Ram_reg 7[7:0]							Data[7:0]
0x2A	Ram_reg 8[7:0]							Data[7:0]
0x2B	Ram_reg 9[7:0]							Data[7:0]
0x2C	Ram_reg 10[7:0]							Data[7:0]
0x2D	Ram_reg 11[7:0]							Data[7:0]
0x2E	Ram_reg 12[7:0]							Data[7:0]
0x2F	Ram_reg 13[7:0]							Data[7:0]
0x30	Ram_reg 14[7:0]							Data[7:0]
0x31	Ram_reg 15[7:0]							Data[7:0]
0x32	Ram_reg 16[7:0]							Data[7:0]
0x33	Ram_reg 17[7:0]							Data[7:0]
0x34	Ram_reg 18[7:0]							Data[7:0]
0x35	Ram_reg 19[7:0]							Data[7:0]
0x36	Ram_reg 20[7:0]							Data[7:0]
0x37	Ram_reg 21[7:0]							Data[7:0]
0x38	Ram_reg 22[7:0]							Data[7:0]
0x39	Ram_reg 23[7:0]							Data[7:0]
0x3A	Ram_reg 24[7:0]							Data[7:0]
0x3B	Ram_reg 25[7:0]							Data[7:0]
0x3C	Ram_reg 26[7:0]							Data[7:0]
0x3D	Ram_reg 27[7:0]							Data[7:0]
0x3E	Ram_reg 28[7:0]							Data[7:0]
0x3F	Ram_reg 29[7:0]							Data[7:0]
0x40	Ram_reg 30[7:0]							Data[7:0]
0x41	Ram_reg 31[7:0]							Data[7:0]
0x42	Ram_reg 32[7:0]							Data[7:0]
0x43	Ram_reg 33[7:0]							Data[7:0]
0x44	Ram_reg 34[7:0]							Data[7:0]
0x45	Ram_reg 35[7:0]							Data[7:0]
0x46	Ram_reg 36[7:0]							Data[7:0]
0x47	Ram_reg 37[7:0]							Data[7:0]
0x48	Ram_reg 38[7:0]							Data[7:0]
0x49	Ram_reg 39[7:0]							Data[7:0]
0x4A	Ram_reg 40[7:0]							Data[7:0]
0x4B	Ram_reg 41[7:0]							Data[7:0]
0x4D	Ram_reg 43[7:0]							Data[7:0]
0x4E	Ram_reg 44[7:0]							Data[7:0]
0x4F	Ram_reg 45[7:0]							Data[7:0]

ADDRESS	NAME	MSB						LSB
0x50	Ram_reg 46[7:0]							Data[7:0]
0x51	Ram_reg 47[7:0]							Data[7:0]
0x52	Ram_reg 48[7:0]							Data[7:0]
0x53	Ram_reg 49[7:0]							Data[7:0]
0x54	Ram_reg 50[7:0]							Data[7:0]
0x55	Ram_reg 51[7:0]							Data[7:0]
0x56	Ram_reg 52[7:0]							Data[7:0]
0x57	Ram_reg 53[7:0]							Data[7:0]
0x58	Ram_reg 54[7:0]							Data[7:0]
0x59	Ram_reg 55[7:0]							Data[7:0]
0x5A	Ram_reg 56[7:0]							Data[7:0]
0x5B	Ram_reg 57[7:0]							Data[7:0]
0x5C	Ram_reg 58[7:0]							Data[7:0]
0x5D	Ram_reg 59[7:0]							Data[7:0]
0x5E	Ram_reg 60[7:0]							Data[7:0]
0x5F	Ram_reg 61[7:0]							Data[7:0]
0x60	Ram_reg 62[7:0]							Data[7:0]
0x61	Ram_reg 63[7:0]							Data[7:0]

Register Details

[Status \(0x0\)](#)

Interrupt Status Register

BIT	7	6	5	4	3	2	1	0
Field	PSDECT	OSF	PFAIL	–	TSF	TIF	A2F	A1F
Reset	0x0	0x1		–	0x0	0x0	0x0	0x0
Access Type	Read Only	Read Clears All	Read Clears All	–	Read Clears All	Read Clears All	Read Clears All	Read Clears All

BITFIELD	BITS	DESCRIPTION	DECODE
PSDECT	7	Main supply source indication when the part is in auto mode	0x0: Part is running on V _{CC} 0x1: Part is running on V _{BAT}
OSF	6	Oscillator stop flag	0x0: Set to 0 when oscillator is running or when DOSF = 1. 0x1: Set to 1 when oscillator has stopped. An interrupt will not be generated on pin INT.
PFAIL	5	Power-fail flag	0x0: Set to zero when there is no power-fail condition on V _{BAT} . 0x1: Set to 1 when there is an external interrupt on V _{BAT} . When this is set to '1', and PFAILE = 1, an interrupt will be generated on pin INT. After an initial power-fail condition occurs, if the condition does not persist, this bit can only be cleared by reading the Status register.

BITFIELD	BITS	DESCRIPTION	DECODE
TSF	3	Temp sense data flag: Indicates when user requested temp measurement is ready. (Only applicable in oneshot mode)	0x0: TS data not ready 0x1: Set to 1 when TS data ready. When this is set to '1', and $\overline{TSIE} = 1$, an interrupt will be generated on pin \overline{INT} .
TIF	2	Timer interrupt flag	0x0: Set to zero when count down timer is not zero. 0x1: Set to 1 when countdown timer reaches to zero. When this is set to '1', and $\overline{TIE} = 1$, an interrupt will be generated on pin \overline{INT} .
A2F	1	Alarm2 interrupt flag	0x0: Set to zero when RTC time doesn't match to alarm2 register. 0x1: Set to 1 when RTC time matches the alarm2 register. When this bit is set, and $\overline{A2IE} = 1$, an interrupt will be generated on \overline{INT} .
A1F	0	Alarm1 Interrupt flag	0x0: When set to zero resets the digital block. 0x1: When set one then device is not on reset mode.

[Int_en \(0x1\)](#)

Interrupt Enable Register

BIT	7	6	5	4	3	2	1	0
Field	–	DOSF	PFAILE	–	TSIE	TIE	A2IE	A1IE
Reset	–	0x0	0x0	–	0x0	0x0	0x0	0x0
Access Type	–	Write, Read	Write, Read	–	Write, Read	Write, Read	Write, Read	Write, Read

BITFIELD	BITS	DESCRIPTION	DECODE
DOSF	6	Disable oscillator flag	0x0: Allow the OSF to indicate the oscillator status. 0x1: Disable the oscillator flag, irrespective of the oscillator status.
PFAILE	5	Power fail Interrupt enable	0x0: When set to zero, analog interrupt function is disabled. 0x1: When set to one, analog interrupt function is enabled.
TSIE	3	Temp sense ready flag enable	0x0: Disable temp sense ready function 0x1: Enable temp sense ready function
TIE	2	Timer interrupt enable	0x0: Disable timer interrupt function 0x1: Enable timer interrupt function
A2IE	1	Alarm2 interrupt enable	0x0: Disable alarm2 interrupt function 0x1: Enable alarm2 interrupt function
A1IE	0	Alarm1 interrupt enable	0x0: Disable alarm1 interrupt function 0x1: Enable alarm1 interrupt function

[RTC_reset \(0x2\)](#)

RTC Software Reset Register

BIT	7	6	5	4	3	2	1	0
Field	–	–	–	–	–	–	–	SWRST
Reset	–	–	–	–	–	–	–	0x0
Access Type	–	–	–	–	–	–	–	Write, Read

BITFIELD	BITS	DESCRIPTION	DECODE
SWRST	0	Active-high software reset bit	0x0: When set to 0, the device is in normal working mode. 0x1: Set to one to reset digital blocks and all user registers except RAM and SWRST. Oscillator is disabled.

[RTC_config1 \(0x3\)](#)

RTC Configuration Register

BIT	7	6	5	4	3	2	1	0
Field	–	–	–	DATA_RET	I2C_TIMEO UT	–	ENOSC	RESERVED
Reset	–	–	–	0x0	0x1	–	0x1	0x0
Access Type	–	–	–	Write, Read	Write, Read	–	Write, Read	Write, Read

BITFIELD	BITS	DESCRIPTION	DECODE
DATA_RET	4	Data retention bit. Before programming DATARETEN, user needs to wait for any ongoing temperature sensor measurement cycles to complete. This depends on whether AUTOMODE or ONESHOTMODE is configured. In AUTOMODE, first program AUTOMODE to 0, and then wait for 100mSec. In ONEHSOTMODE, wait for 100mSec	0x0: Normal operation mode 0x1: Data retention mode
I2C_TIMEO T	3	I ² C timeout enable	0x0: Disables I ² C timeout 0x1: Enables I ² C timeout
ENOSC	1	Active-high enable for oscillator	0x0: Disable oscillator 0x1: Enable oscillator
RESERVED	0	Reserved	0x0: This bit has to be set to 0.

[RTC_config2 \(0x4\)](#)

RTC Configuration Register

BIT	7	6	5	4	3	2	1	0
Field	ENCLKO	CLKO_HZ[3:0]			SQW_HZ[2:0]			
Reset	0x0	0x8			0x0			
Access Type	Write, Read	Write, Read			Write, Read			

BITFIELD	BITS	DESCRIPTION	DECODE
ENCLKO	7	CLKO enable	0x0: Disable output clock on CLKO; CLKO set to Hi-Z 0x1: Enable output clock on CLKO

BITFIELD	BITS	DESCRIPTION	DECODE
CLKO_HZ	6:3	Specify uncompensated clock frequency output on pin CLKO.	0x0: 1.0032Hz 0x1: 2.0065Hz 0x2: 4.0130Hz 0x3: 8.0261Hz 0x4: 16.0522Hz 0x5: 32.1044Hz 0x6: 64.2089Hz 0x7: 128.4179Hz 0x8: 32.875kHz 0x9: 32.875kHz 0xA: 32.875kHz 0xB: 32.875kHz 0xC: 32.875kHz 0xD: 32.875kHz 0xE: 32.875kHz 0xF: 32.875kHz
SQW_HZ	2:0	Set output clock on SQW to specified frequency	0x0: 1Hz 0x1: 2Hz 0x2: 4Hz 0x3: 8Hz 0x4: 16Hz 0x5: 32Hz 0x6: 32Hz 0x7: 32Hz

Timer config (0x5)

Countdown Timer Configuration Register

BIT	7	6	5	4	3	2	1	0
Field	–	–	–	TE	TPAUSE	TRPT	TFS[1:0]	
Reset	–	–	–	0x0	0x0	0x1	0x0	
Access Type	–	–	–	Write, Read	Write, Read	Write, Read	Write, Read	

BITFIELD	BITS	DESCRIPTION	DECODE
TE	4	Timer enable. Also refer TPAUSE field for additional information.	0x0: Timer is reset when set to zero. New timer countdown value (Timer_Init) can be programmed in this state. Note: In this state, ensure TPAUSE is also programmed to 0, if TPAUSE was set to 1 earlier. 0x1: Timer starts counting down from the value programmed in Timer_Init.
TPAUSE	3	Timer Pause. This field is valid only when TE = 1. When TE will be programmed to 0, this field must also be reset to 0. Details about Timer Pause are explained in detail in another section of the datasheet.	0x0: Timer continues to count down from the paused count value as per programming. 0x1: Timer is paused, however, the count value is retained. When this bit is reset back to 0, count down continues from the paused value.
TRPT	2	Timer repeat mode. Controls the timer interrupt function.	0x0: Countdown timer will halt once it reaches zero 0x1: Countdown timer reloads the value from the timer initial register upon reaching zero and continues counting.

BITFIELD	BITS	DESCRIPTION	DECODE
TFS	1:0	Timer frequency selection	0x0: 1024Hz 0x1: 256Hz 0x2: 64Hz 0x3: 16Hz

Seconds (0x6)

Seconds Configuration Register

BIT	7	6	5	4	3	2	1	0
Field	–	sec_10[2:0]			seconds[3:0]			
Reset	–	0x0			0x0			
Access Type	–	Write, Read			Write, Read			

BITFIELD	BITS	DESCRIPTION
sec_10	6:4	RTC seconds in multiples of 10
seconds	3:0	RTC seconds value.

Minutes (0x7)

Minutes Configuration Register

BIT	7	6	5	4	3	2	1	0
Field	–	min_10[2:0]			minutes[3:0]			
Reset	–	0x0			0x0			
Access Type	–	Write, Read			Write, Read			

BITFIELD	BITS	DESCRIPTION
min_10	6:4	RTC minutes in multiples of 10
minutes	3:0	RTC minutes value

Hours (0x8)

Hours Configuration Register

BIT	7	6	5	4	3	2	1	0
Field	–	–	hr_10[1:0]		hour[3:0]			
Reset	–	–	0x0		0x0			
Access Type	–	–	Write, Read		Write, Read			

BITFIELD	BITS	DESCRIPTION
hr_10	5:4	RTC hours in multiples of 10
hour	3:0	RTC hours value

Day (0x9)

Day Configuration Register

BIT	7	6	5	4	3	2	1	0
Field	–	–	–	–	–	day[2:0]		
Reset	–	–	–	–	–	0x1		
Access Type	–	–	–	–	–	Write, Read		

BITFIELD	BITS	DESCRIPTION
day	2:0	RTC days

[Date \(0xA\)](#)

Date Configuration Register

BIT	7	6	5	4	3	2	1	0
Field	–	–	date_10[1:0]		date[3:0]			
Reset	–	–	0x0		0x1			
Access Type	–	–	Write, Read		Write, Read			

BITFIELD	BITS	DESCRIPTION
date_10	5:4	RTC date in multiples of 10
date	3:0	RTC date

[Month \(0xB\)](#)

Month Configuration Register

BIT	7	6	5	4	3	2	1	0
Field	century	–	–	month_10	month[3:0]			
Reset	0x0	–	–	0x0	0x1			
Access Type	Write, Read	–	–	Write, Read	Write, Read			

BITFIELD	BITS	DESCRIPTION	DECODE
century	7	Century bit	0x0: Current year is not a century 0x1: Current year is a century
month_10	4	RTC month in multiples of 10	
month	3:0	RTC months	

[Year \(0xC\)](#)

Year Configuration Register

BIT	7	6	5	4	3	2	1	0
Field	year_10[3:0]				year[3:0]			
Reset	0x0				0x0			
Access Type	Write, Read				Write, Read			

BITFIELD	BITS	DESCRIPTION
year_10	7:4	RTC year multiples of 10
year	3:0	RTC years

[Alm1_sec \(0xD\)](#)

DY_DT	A1M6	A1M5	A1M4	A1M3	A1M2	A1M1	ALARM RATE
x	1	1	1	1	1	1	Once per sec
x	1	1	1	1	1	0	Sec match
x	1	1	1	1	0	0	Min and sec match
x	1	1	1	0	0	0	Hour, min, and sec match
0	1	1	0	0	0	0	Date and Time match
0	1	0	0	0	0	0	Month, Date, and Time match
0	0	0	0	0	0	0	Year, Month, Date, and Time match
1	1	1	0	0	0	0	Day and Time match

Alarm 1 can be set by writing to registers 0Dh - 12h. See register map. The alarm can be programmed by the A1IE bit in Int_en reg (01h) register to activate the INT output on an alarm match condition. Bit 7 of each of the time-of-day/ date alarm registers, and Bit 7 & 6 of month alarm register are mask bits. When all the mask bits of each alarm are logic 0, an alarm only occurs when the values in the timekeeping registers match the corresponding values stored in the time-of-day/date alarm registers. The alarm can also be programmed to repeat every second, minute, hour, day, date, month, or year. Table above, shows the possible settings. Configurations not listed in the table result in illogical operation. The DY_DT bit (bit 6 of the alarm day/date registers) control whether the alarm value stored in bits 0-5 that register reflects the day of the week or the date of the month. If DY_DT is written to logic 0, the alarm is the result of a match with date of the month. If DY_DT is written to logic 1, the alarm is the result of a match with day of the week.

BIT	7	6	5	4	3	2	1	0
Field	A1M1	sec_10[2:0]			seconds[3:0]			
Reset	0x0	0x0			0x0			
Access Type	Write, Read	Write, Read			Write, Read			

BITFIELD	BITS	DESCRIPTION
A1M1	7	Alarm1 mask bit for seconds
sec_10	6:4	Alarm1 seconds in multiples of 10
seconds	3:0	Alarm1 seconds

[Alm1_min \(0xE\)](#)

Alarm1 Minutes Configuration Register

BIT	7	6	5	4	3	2	1	0
Field	A1M2	min_10[2:0]			minutes[3:0]			
Reset	0x0	0x0			0x0			
Access Type	Write, Read	Write, Read			Write, Read			

BITFIELD	BITS	DESCRIPTION
A1M2	7	Alarm1 mask bit for minutes
min_10	6:4	Alarm1 minutes in multiples of 10
minutes	3:0	Alarm1 minutes

[Alm1_hrs \(0xF\)](#)

Alarm1 Hours Configuration Register

BIT	7	6	5	4	3	2	1	0
Field	A1M3	–	hr_10[1:0]		hour[3:0]			
Reset	0x0	–	0x0		0x0			
Access Type	Write, Read	–	Write, Read		Write, Read			

BITFIELD	BITS	DESCRIPTION
A1M3	7	Alarm1 mask bit for hours
hr_10	5:4	Alarm1 hours in multiples of 10
hour	3:0	Alarm1 hours

Alm1day_date (0x10)

Alarm1 Day/Date Configuration Register

BIT	7	6	5	4	3	2	1	0
Field	A1M4	DY_DT	date_10[1:0]		day_date[3:0]			
Reset	0x0	0x0	0x0		0x0			
Access Type	Write, Read	Write, Read	Write, Read		Write, Read			

BITFIELD	BITS	DESCRIPTION	DECODE
A1M4	7	Alarm1 mask bit for day/date	
DY_DT	6		0x0: Alarm when date match 0x1: Alarm when day match
date_10	5:4	Alarm1 date in multiples of 10	
day_date	3:0	Alarm1 day/date	

Alm1_mon (0x11)

Alarm1 Month Configuration Register

BIT	7	6	5	4	3	2	1	0
Field	A1M5	A1M6	–	month_10	month[3:0]			
Reset	0b0	0b0	–	0b0	0x0			
Access Type	Write, Read	Write, Read	–	Write, Read	Write, Read			

BITFIELD	BITS	DESCRIPTION
A1M5	7	Alarm1 mask bit for month
A1M6	6	Alarm1 mask bit for year
month_10	4	Alarm1 months in multiples of 10
month	3:0	Alarm1 months

Alm1_year (0x12)

Alarm1 Year Configuration Register

BIT	7	6	5	4	3	2	1	0
Field	year_10[3:0]				year[3:0]			
Reset	0x0				0x0			
Access Type	Write, Read				Write, Read			

BITFIELD	BITS	DESCRIPTION
year_10	7:4	Alarm1 year in multiples of 10
year	3:0	Alarm1 years

[Alm2_min \(0x13\)](#)

Alarm 2 can be set by writing to registers 13h - 15h. See register map. The alarm can be programmed by the A2IE bit in Int_en reg (01h) register to activate the INT output on an alarm match condition. Bit 7 of each of the time-of-day/ date alarm registers are mask bits. When all the mask bits of each alarm are logic 0, an alarm only occurs when the values in the timekeeping registers match the corresponding values stored in the time-of-day/date alarm registers. The alarm can also be programmed to repeat every minute, hour, day, or date. Table below, shows the possible settings. Configurations not listed in the table result in illogical operation. The DY_DT bit (bit 6 of the alarm day/date registers) control whether the alarm value stored in bits 0-5 that register reflects the day of the week or the date of the month. If DY_DT is written to logic 0, the alarm is the result of a match with date of the month. If DY_DT is written to logic 1, the alarm is the result of a match with day of the week.

DY_DT	A2M4	A2M3	A2M2	ALARM RATE
x	1	1	1	Once per minute
x	1	1	0	Minute match
x	1	0	0	Hour and minute match
0	0	0	0	Date, hour, and minute match
1	0	0	0	Day, hour, and minute match

BIT	7	6	5	4	3	2	1	0
Field	A2M2	min_10[2:0]			minutes[3:0]			
Reset	0x0	0x0			0x0			
Access Type	Write, Read	Write, Read			Write, Read			

BITFIELD	BITS	DESCRIPTION
A2M2	7	Alarm2 mask bit for minutes
min_10	6:4	Alarm2 minutes in multiples of 10
minutes	3:0	Alarm2 minutes

[Alm2_hrs \(0x14\)](#)

Alarm2 Hours Configuration Register

BIT	7	6	5	4	3	2	1	0
Field	A2M3	–	hr_10[1:0]		hour[3:0]			
Reset	0x0	–	0x0		0x0			
Access Type	Write, Read	–	Write, Read		Write, Read			

BITFIELD	BITS	DESCRIPTION
A2M3	7	Alarm2 mask bit for hours

BITFIELD	BITS	DESCRIPTION
hr_10	5:4	Alarm2 hours in multiples of 10
hour	3:0	Alarm2 hours

[Alm2day_date \(0x15\)](#)

Alarm2 Day/Date Configuration Register

BIT	7	6	5	4	3	2	1	0
Field	A2M4	DY_DT	date_10[1:0]		day_date[3:0]			
Reset	0x0	0x0	0x0		0x0			
Access Type	Write, Read	Write, Read	Write, Read		Write, Read			

BITFIELD	BITS	DESCRIPTION	DECODE
A2M4	7	Alarm2 mask bit for day/date	
DY_DT	6	This bit selects alarm when day match or date match.	0x0: Alarm when date match 0x1: Alarm when day match
date_10	5:4	Alarm2 date in multiples of 10	
day_date	3:0	Alarm2 day/date	

[Timer_Count \(0x16\)](#)

Countdown Timer Value Register

BIT	7	6	5	4	3	2	1	0
Field	Count[7:0]							
Reset	0x00							
Access Type	Read Only							

BITFIELD	BITS	DESCRIPTION
Count	7:0	Count down timer current count value. The current timer value can be read by reading this register.

[Timer_Init \(0x17\)](#)

Countdown Timer Initialization Register

BIT	7	6	5	4	3	2	1	0
Field	Count[7:0]							
Reset	0x00							
Access Type	Write, Read							

BITFIELD	BITS	DESCRIPTION
Count	7:0	Count down timer initial value. The timer is loaded with the contents of this register when it reaches to zero in repeat mode.

[Pwr_mgmt \(0x18\)](#)

Power Management Configuration Register

BIT	7	6	5	4	3	2	1	0
Field	–	–	PFVT[1:0]		D_VBACK_SEL	D_MAN_SEL	–	–
Reset	–	–	0x3		0x0	0x0	–	–
Access Type	–	–	Write, Read		Write, Read	Write, Read	–	–

BITFIELD	BITS	DESCRIPTION	DECODE
PFVT	5:4	Power fail threshold voltage. Sets analog comparator threshold voltage. Require D_MAN_SEL = 0 for this setting to have effect.	0x0: Reserved 0x1: 1.8V 0x2: 2.0V 0x3: 2.4V
D_VBACK_SEL	3	Backup battery select. Require D_MAN_SEL = 1 for this bit to have effect.	0x0: Use V _{CC} as supply. 0x1: Use V _{backup} as supply.
D_MAN_SEL	2	When this bit is low, input control block decides which supply to use. And this bit is low, power management comparators are enabled. When this bit is high, comparators are disabled and user can manually select whether to use V _{CC} or V _{BACKUP} as supply.	0x0: Circuit decides whether to use V _{CC} or V _{BACKUP} as supply. 0x1: User decides whether to use V _{CC} or V _{BACKUP} as supply by setting D_VBACK_SEL bit.

[Trickle_reg \(0x19\)](#)

Trickle Charge Configuration Register

BIT	7	6	5	4	3	2	1	0
Field	TCHE[3:0]				D_TRICKLE[3:0]			
Reset	0x0				0x0			
Access Type	Write, Read				Write, Read			

BITFIELD	BITS	DESCRIPTION	DECODE
TCHE	7:4	Trickle charger enable. Only 1 of 16 codes enables trickle charger.	0x0: Trickle charger disabled 0x1: Trickle charger disabled 0x2: Trickle charger disabled 0x3: Trickle charger disabled 0x4: Trickle charger disabled 0x5: Trickle charger enabled 0x6: Trickle charger disabled 0x7: Trickle charger disabled 0x8: Trickle charger disabled 0x9: Trickle charger disabled 0xA: Trickle charger disabled 0xB: Trickle charger disabled 0xC: Trickle charger disabled 0xD: Trickle charger disabled 0xE: Trickle charger disabled 0xF: Trickle charger disabled

BITFIELD	BITS	DESCRIPTION	DECODE
D_TRICKLE	3:0	Sets the charging path for trickle charger. Must set TCHE to 0x5 to enable the setting below.	0x0: 3KΩ in series with a Schottky diode 0x1: 3KΩ in series with a Schottky diode 0x2: 6KΩ in series with a Schottky diode 0x3: 11KΩ in series with a Schottky diode 0x4: 3KΩ in series with a diode+Schottky diode 0x5: 3KΩ in series with a diode+Schottky diode 0x6: 6KΩ in series with a diode+Schottky diode 0x7: 11KΩ in series with a diode+Schottky diode 0x8: No Connection 0x9: No Connection 0xA: No Connection 0xB: No Connection 0xC: No Connection 0xD: No Connection 0xE: No Connection 0xF: No Connection

Temp_MSB (0x1A)

Temperature sensor measurement is stored as a 10-bit two’s complement number in two-byte temperature register. SIGN bit indicates if the temperature is positive or negative. When SIGN bit is 1, it represents negative temperature, and it has a weight of -128. Bit [5:0] are redundant. Bit 6 of Temperature [15:0] is LSB and has a weight of 0.25. Table below represent weight of each bit from Bit 6 to Bit 14.

Temperature Register Definition

MSB								LSB							
D15	D14	D13	D12	D11	D10	D9	D8	D7	D6	D5	D4	D3	D2	D1	D0
SIGN	64°C	32°C	16°C	8°C	4°C	2°C	1°C	0.5°C	0.25°C	0	0	0	0	0	0

Temperature Format Examples

TEMPERATURE (°C)	Temp_MSB [15:8]	Temp_LSB [7:0]
85°C	0101 0101	0000 0000
84.75°C	0101 0100	1100 0000
0°C	0000 0000	0000 0000
-0.25°C	1111 1111	1100 0000
-40°C	1101 1000	0000 0000

Assuming user reads Temp_MSB and Temp_LSB registers as Temp_MSB = 8'b01010100, Temp_LSB = 8'b11000000. Per Table above, Bit 15 = 0 means positive temperature, 64X1 + 32X0 + 16X1 + 8X0 + 4X1 + 2X0 + 1X0 = 84°C, 0.5X1 + 0.25X1 = 0.75°C. Hence, temperature = 84.75°C.

BIT	7	6	5	4	3	2	1	0
Field	Temperature[15:8]							
Reset								
Access Type	Read Only							

BITFIELD	BITS	DESCRIPTION
Temperature	7:0	MSB of the 16-bit temperature register

[Temp_LSB \(0x1B\)](#)

Temperature Value LSB Register

BIT	7	6	5	4	3	2	1	0
Field	Temperature[7:0]							
Reset								
Access Type	Read Only							

BITFIELD	BITS	DESCRIPTION
Temperature	7:0	LSB of the 16-bit temperature register.

[TS_config \(0x1C\)](#)

Temperature Sensor Configuration Register

BIT	7	6	5	4	3	2	1	0
Field	AUTOMODE	ONESHOTMODE	TTSINT[2:0]			–	–	–
Reset	0x1	0x0	0x5			–	–	–
Access Type	Write, Read	Write, Read	Write, Read			–	–	–

BITFIELD	BITS	DESCRIPTION	DECODE
AUTOMODE	7	Automatic mode of temperature measurement. This mode is valid only when ONESHOTMODE = 0. In this mode, temperature measurement interval is decided by TTSINT. After each temperature measurement request, the divider ratio will be modified for temperature compensation.	0x0: Automatic measurement mode disabled 0x1: Automatic measurement mode enabled
ONESHOTMODE	6	One-shot user-requested temperature measurement in real-time. AUTOMODE must be 0 in one-shot measurement mode. When this bit is set, divider ratio is updated (compensated) after temperature measurement. This bit is self-cleared after temperature measurement complete; writes to this bit before it has been cleared have no effect.	0x0: No temperature measurement requested 0x1: Temperature measurement requested
TTSINT	5:3	Set temperature measurement interval to specified time for automatic mode of temperature measurement and compensation	0x0: 1sec 0x1: 2sec 0x2: 4sec 0x3: 8sec 0x4: 16sec 0x5: 32sec 0x6: 64sec 0x7: 128sec

[Ram reg \(0x22, 0x23, 0x24, 0x25, 0x26, 0x27, 0x28, 0x29, 0x2A, 0x2B, 0x2C, 0x2D, 0x2E, 0x2F, 0x30, 0x31, 0x32, 0x33, 0x34, 0x35, 0x36, 0x37, 0x38, 0x39, 0x3A, 0x3B, 0x3C, 0x3D, 0x3E, 0x3F, 0x40, 0x41, 0x42,](#)

MAX31343

±5ppm, I²C Real-Time Clock with Integrated
MEMS Oscillator

[0x43, 0x44, 0x45, 0x46, 0x47, 0x48, 0x49, 0x4A, 0x4B, 0x4C, 0x4D, 0x4E, 0x4F, 0x50, 0x51, 0x52, 0x53, 0x54, 0x55, 0x56, 0x57, 0x58, 0x59, 0x5A, 0x5B, 0x5C, 0x5D, 0x5E, 0x5F, 0x60, 0x61](#))

BIT	7	6	5	4	3	2	1	0
Field	Data[7:0]							
Reset								
Access Type	Write, Read							

BITFIELD	BITS	DESCRIPTION
Data	7:0	RAM data byte

Applications Information

Power-Supply Decoupling

To achieve the best results when using the device, decouple the V_{CC} and/or V_{BAT} power supplies with 0.1µF and/or 1.0µF capacitors. Use a high-quality ceramic surface-mount capacitor if possible. Surface-mount components minimize lead inductance which improves performance and ceramic capacitors tend to have adequate high-frequency response for decoupling applications.

If communications during battery operation are not required, the V_{BAT} decoupling capacitor can be omitted.

Using Open-Drain Outputs

The \overline{INT} and SQW outputs are open-drain and, therefore, require external pullup resistors to realize logic-high output levels. Pullup resistor values between 1kΩ and 10MΩ are typical.

SDA and SCL Pullup Resistors

SDA is an open-drain output and requires an external pullup resistor to realize a logic-high level. Because the device does not use clock cycle stretching, a master using either an open-drain output with a pullup resistor or CMOS output driver (push-pull) could be used for SCL.

Handling

The MAX31343 package contains an integrated resonator. Pick-and-place equipment can be used. Ultrasonic cleaning should be avoided to prevent damage to the resonator.

Typical Application Circuit

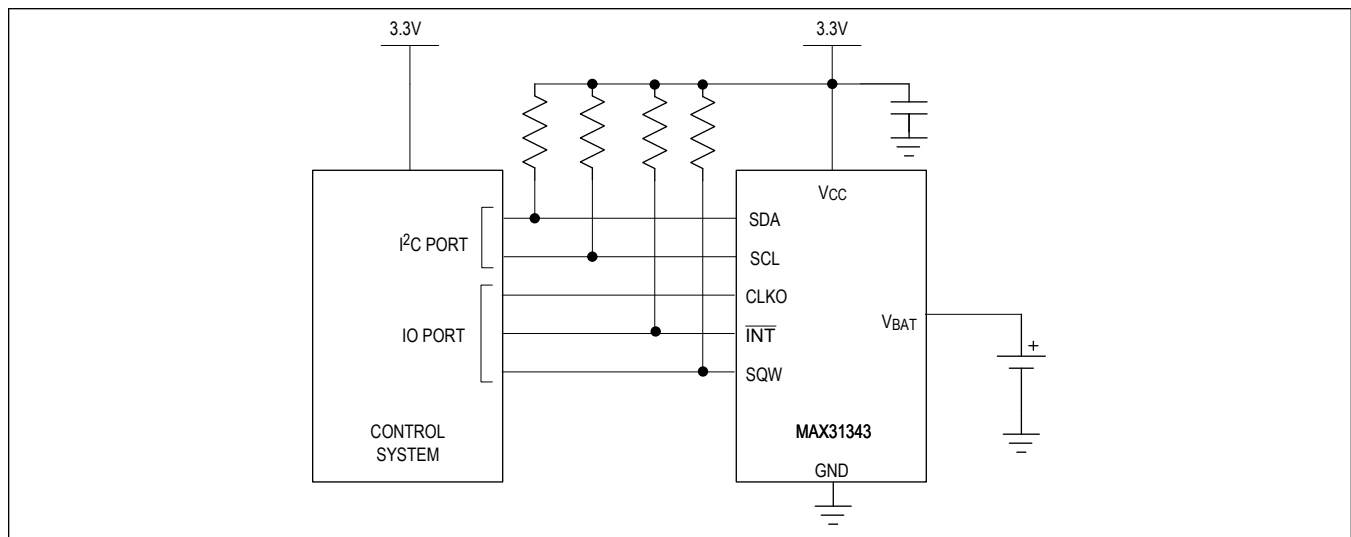

Ordering Information

PART NUMBER	TEMPERATURE RANGE	PIN-PACKAGE
MAX31343EKA+T	-40°C to +85°C	2.1mm x 2.3mm, 8-Pin WLP
MAX31343ETAY+T	-40°C to +85°C	3mm x 4mm, 8-Pin TDFN

+Denotes a lead(Pb)-free/RoHS-compliant package.

Revision History

REVISION NUMBER	REVISION DATE	DESCRIPTION	PAGES CHANGED
0	12/19	Initial release	—
1	4/20	Updated aging performance, frequency accuracy, package dimensions, and storage temperature; updated Data-Retention Mode section; updated Figure 4	1, 6-8, 13, 17, 38
2	9/20	Updated <i>Ordering Information</i> table	38
3	6/21	Updated <i>Package Information</i> and <i>Electrical Characteristics</i> table	6, 8
4	10/21	Updated <i>Electrical Characteristics</i> table and <i>Register Map</i>	6, 9, 26
5	11/21	Updated Table 2 and <i>Register Map</i>	14, 22, 28, 31, 33