

THIS DRAWING IS UNPUBLISHED. RELEASED FOR PUBLICATION
 © COPYRIGHT copyright.d8te- ALL RIGHTS RESERVED.

REVISIONS				
P	LTR	DESCRIPTION	DATE	APVD
	A	FIRST RELEASED	17DEC15	NINA DANIEL

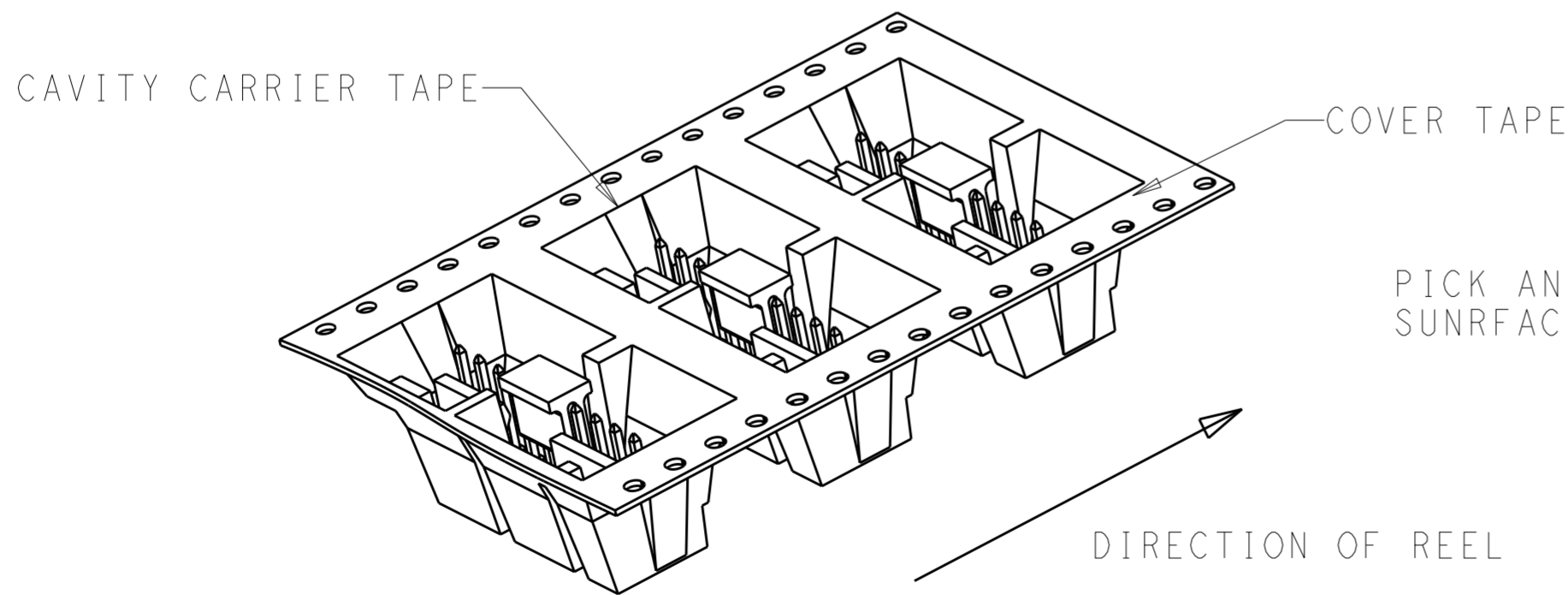
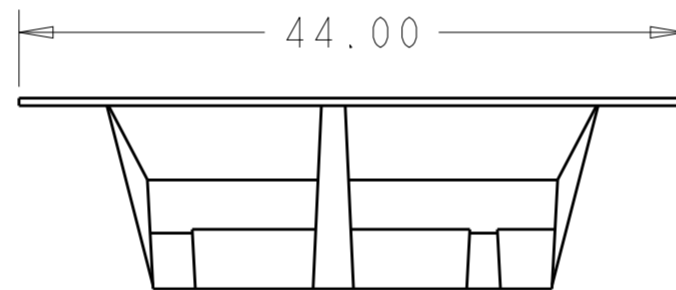
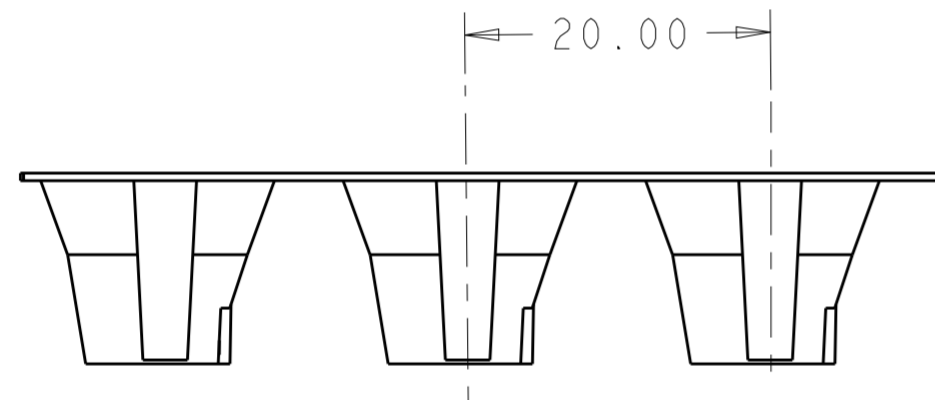
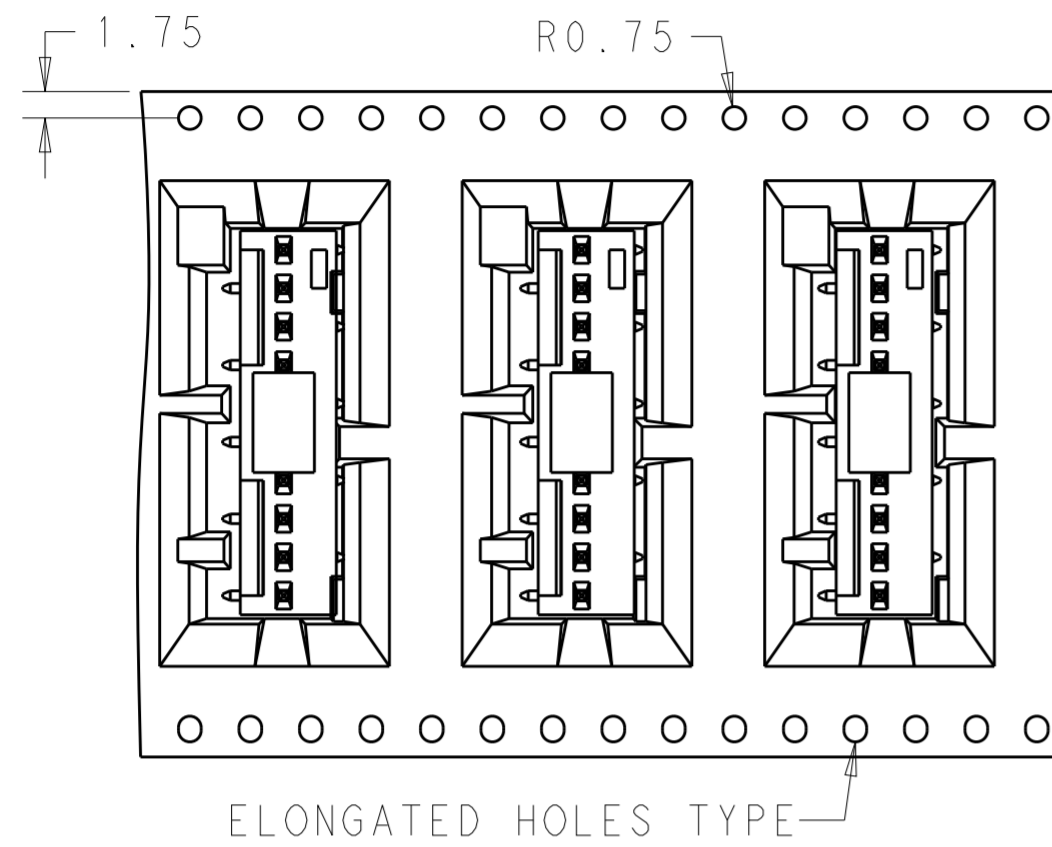

PICK AND PLACE 147117-1
 SUNRFACE MOUNT HEADER 4-647166-0

- 1. MATERIAL:
 HOUSING- NYLON, UL94V-0, BLACK
 CONTACT- COPPER ALLOY
 CAVITY CARRIER TAPE- BLACK CONDUCTIVE PLOYCARBONATE
- 2. FINISH:
 CONTACT - TIN PLATE
- 3. POSTS SOLDERTAILS MUST COMPLY WITH TE SOLDERABILITY SPEC 109-11-12.
- 4. HEADERS ARE SUPPLIED ON A 330.2mm DIAMETER REEL WITH 225 PARTS PER REEL. THE CAVITY CARRIER TAPE HOLDS 1 PART PER POCKET, ORIENTED AS SHOWN.
- 5. TE LOGO, UL AND CSA TRADEMARKS MARKED AT THIS LOCATION

1 REQ'D	1 REQ'D	10	2297127-1
PICK AND PLACE COVER	HEADER ASSEMBLY	NO. OF POSITIONS	PART NO



THIS DRAWING IS A CONTROLLED DOCUMENT.		DWN NINA 26OCT15	TE Connectivity	
DIMENSIONS: mm		CHK DANIEL 26OCT15		
TOLERANCES UNLESS OTHERWISE SPECIFIED:		APVD DANIEL 26OCT15		
0 PLC ± 1 PLC ± 2 PLC ±0.30 3 PLC ± 4 PLC ± ANGLES ± FINISH		PRODUCT SPEC 108-1050 APPLICATION SPEC 114-1019 WEIGHT -		
MATERIAL		NAME MTA-100 HEADER ASSY, SUFACE MOUNT, CTION LOCK, .025 SQ. POST, TIN PLATED, TAPE LOADED W/CAP		RESTRICTED TO -
		SIZE CAGE CODE DRAWING NO		SCALE N/A SHEET 1 OF 3 REV A
		A200779 C-2297127		
CUSTOMER DRAWING				

THIS DRAWING IS UNPUBLISHED. RELEASED FOR PUBLICATION
 © COPYRIGHT copyright.d8te- ALL RIGHTS RESERVED.

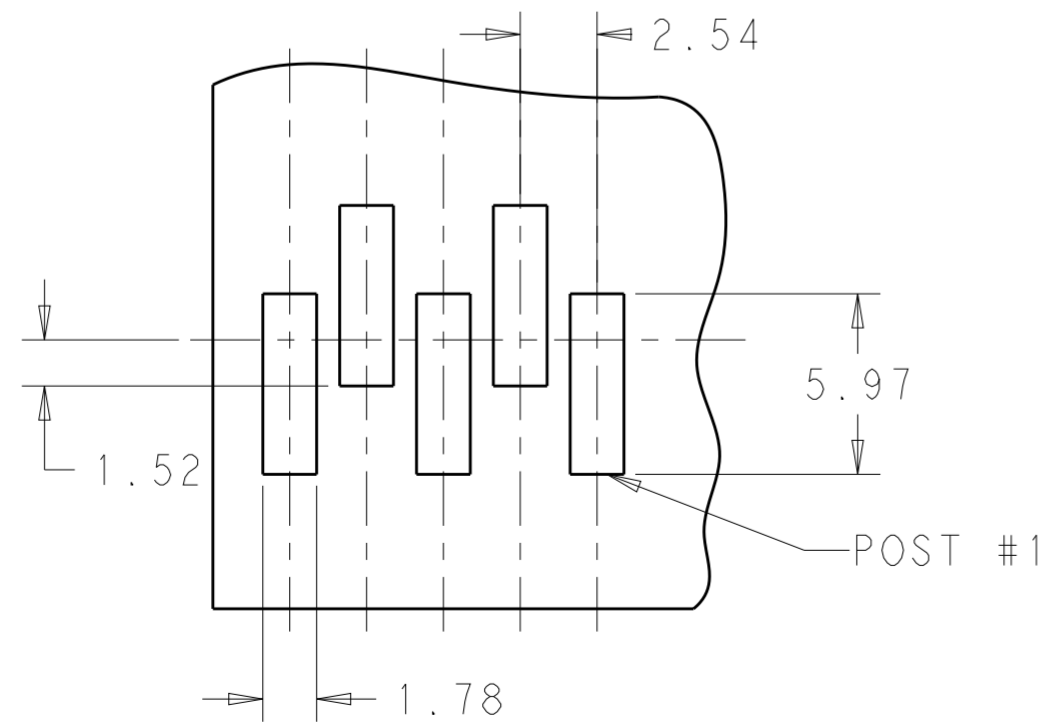
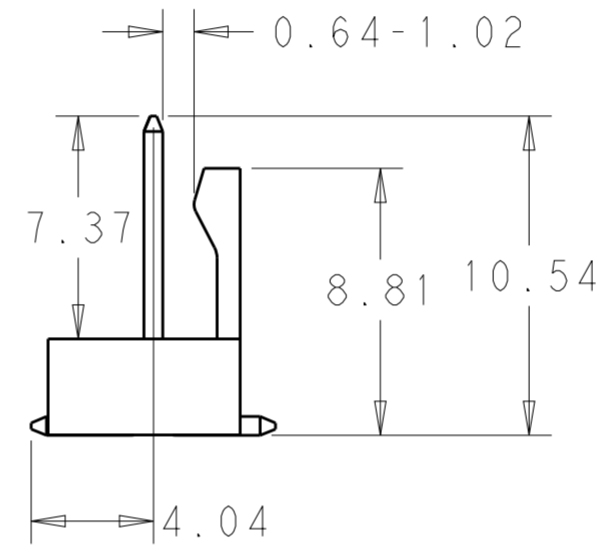
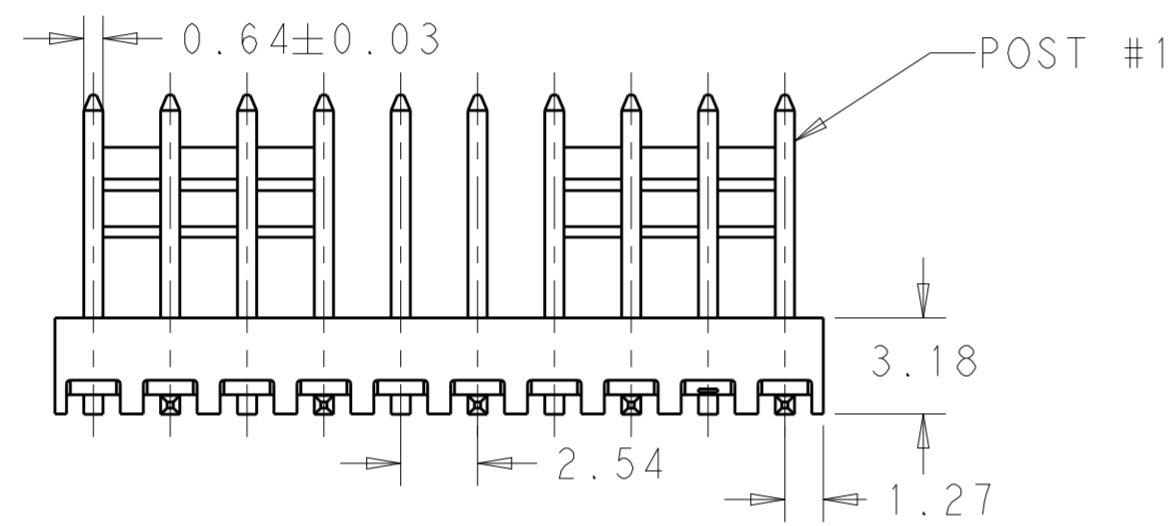
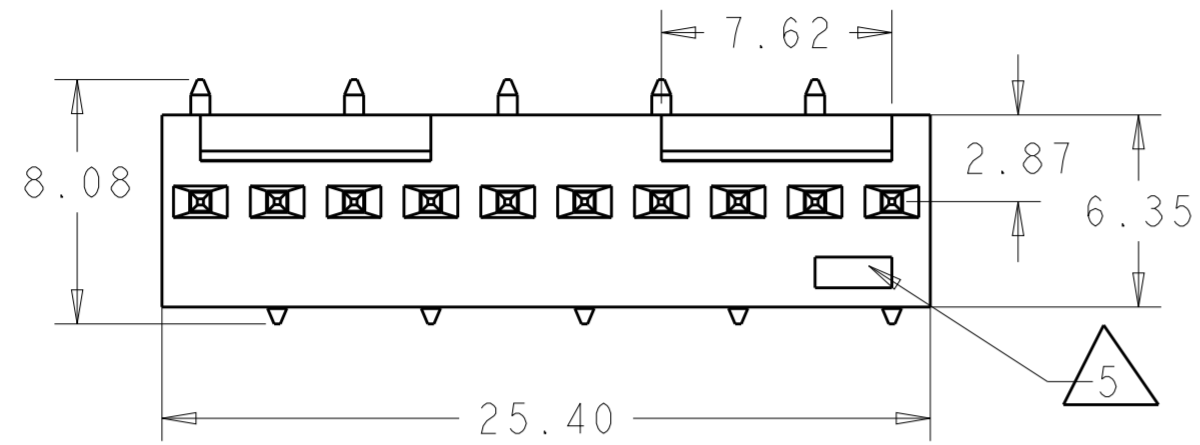
REVISIONS				
P	LTR	DESCRIPTION	DATE	APVD
-	-	SEE SHEET 1	-	-



RECOMMENDED P.C. BOARD LAYOUT
 FOR USE WITH 0.254mm THICK STENCIL

THIS DRAWING IS A CONTROLLED DOCUMENT.		DWN NINA	26OCT15	 TE Connectivity
DIMENSIONS: mm		CHK DANIEL	26OCT15	
TOLERANCES UNLESS OTHERWISE SPECIFIED:		APVD DANIEL	26OCT15	
0 PLC ±- 1 PLC ±- 2 PLC ±0.30 3 PLC ±- 4 PLC ±- ANGLES ±- FINISH		NAME DANIEL	NAME MTA-100 HEADER ASSEMBLY, SUFACE MOUNT, CTION LOCK, .025 SQUARE. STRAIGHT POST.	
MATERIAL		PRODUCT SPEC 108-1050	APPLICATION SPEC 114-1019	SIZE A2
		WEIGHT -	CUSTOMER DRAWING	SCALE N/A
				SHEET 2 OF 3
				REV A

THIS DRAWING IS UNPUBLISHED. RELEASED FOR PUBLICATION
 © COPYRIGHT copyright.dBte- ALL RIGHTS RESERVED.

REVISIONS				
P	LTR	DESCRIPTION	DATE	APVD
-		SEE SHEET 1	-	-

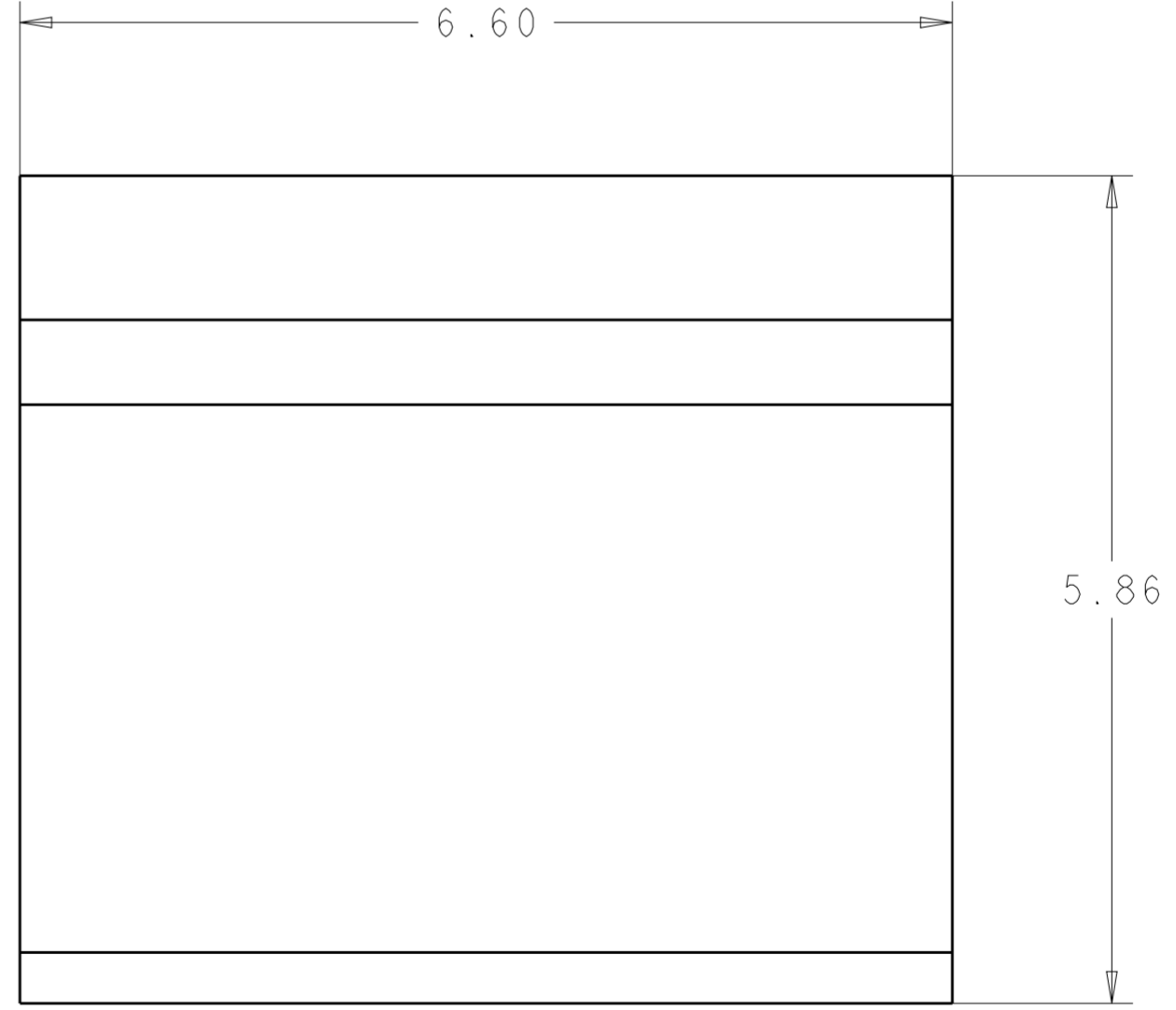
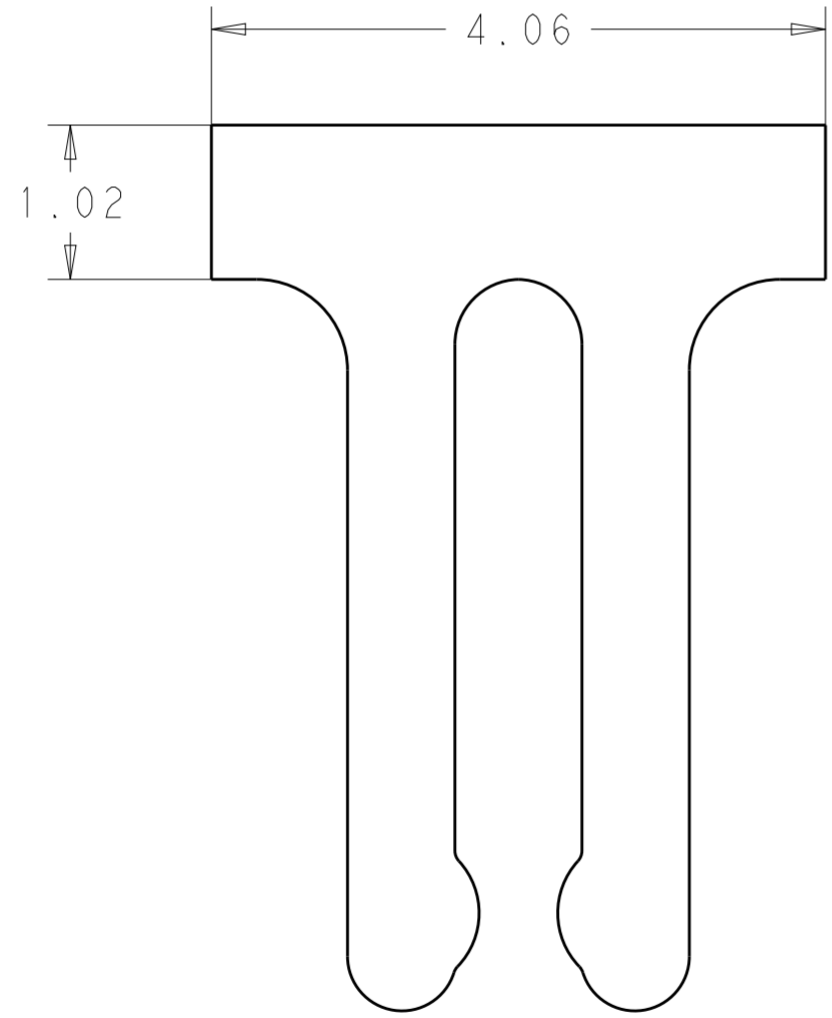
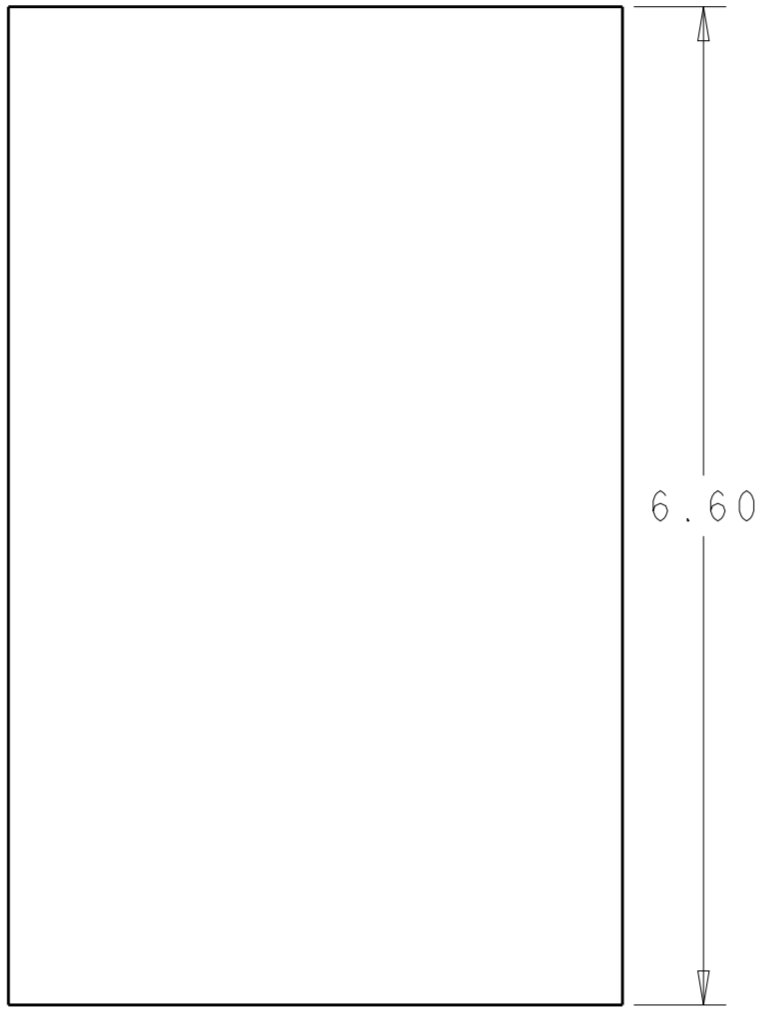

CAP FOR HEADER

THIS DRAWING IS A CONTROLLED DOCUMENT.		DWN NINA 26OCT15	TE Connectivity	
		CHK DANIEL 26OCT15		
		APVD DANIEL 26OCT15	NAME MTA-100 HEADER ASSEMBLY, SUFACE MOUNT, CTION LOCK, .025 SQUARE. STRAIGHT POST.	
DIMENSIONS: mm		PRODUCT SPEC 108-1050	SIZE 114-1019	RESTRICTED TO -
TOLERANCES UNLESS OTHERWISE SPECIFIED: 0 PLC ± 1 PLC ± 2 PLC ±0.30 3 PLC ± 4 PLC ± ANGLES ± FINISH		APPLICATION SPEC 114-1019	SCALE N/A	SHEET 3 OF 3
MATERIAL 		WEIGHT -	CAGE CODE A200779	REV A
		CUSTOMER DRAWING	DRAWING NO C-2297127	