

NEX10

Adaptor  
NEX10® Jack - NEX10® Jack

**89K101-K00N1**

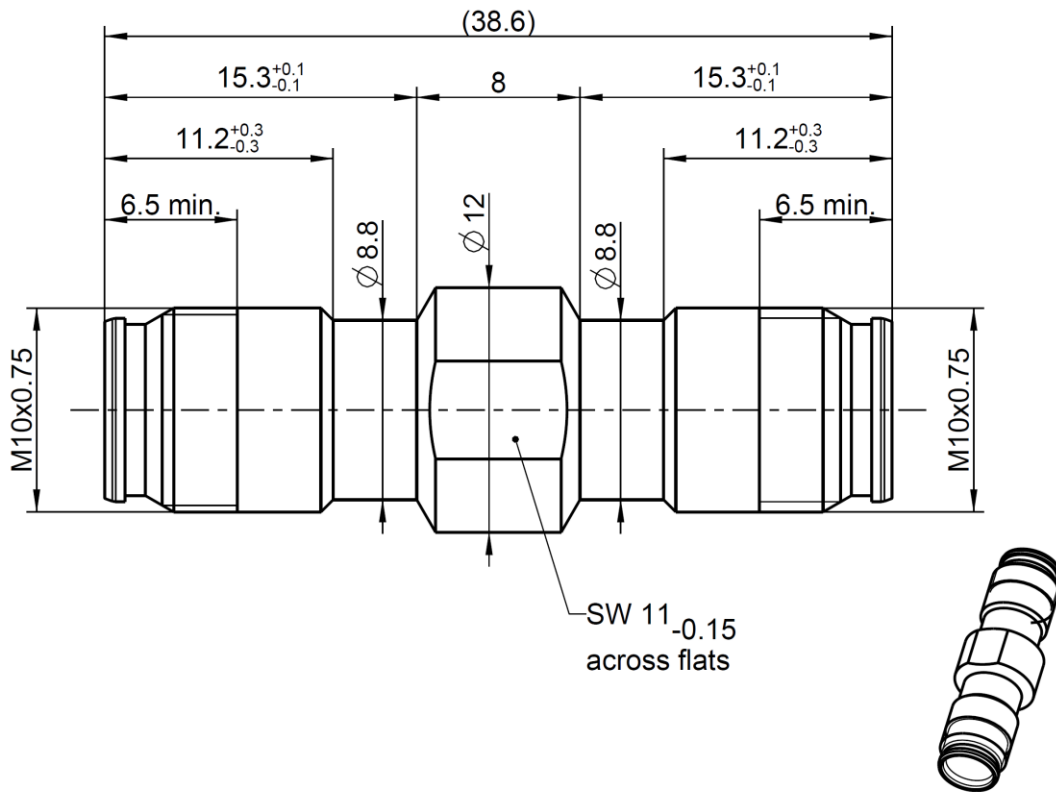

All dimensions are in mm; tolerances according to ISO 2768 m-H

**Interface**

According to NEX10®

**Material and Plating**

**Connector parts**

Center contact  
Outer contact  
Body  
Dielectric

**Material**

CuBe  
Brass  
Brass  
PTFE

**Plating**

Silver, 3-6 µm  
White bronze(e.g. Optalloy®)  
White bronze(e.g. Optalloy®)

NEX10

Adaptor  
NEX10® Jack - NEX10® Jack

**89K101-K00N1**

**Electrical Data**

Impedance 50 Ω  
 Frequency DC to 20 GHz  
 Return loss ≥ 30 dB @ DC to 4 GHz  
 ≥ 28 dB @ 4 GHz to 6 GHz  
 ≥ 25 dB @ 6 GHz to 10 GHz  
 Insertion loss ≤ 0.05 x √ f [GHz] dB  
 Insulation resistance ≥ 5 GΩ  
 Center contact resistance ≤ 2.0 mΩ,  
 Outer contact resistance ≤ 1.0 mΩ,  
 Working voltage 500 V rms  
 RF-leakage ≥ 110 dB @ DC to 6 GHz (tool tightened plugs)  
 Power handling 100 W @ 2.0 GHz and 85 °C ambient temperature

**Mechanical Data**

Mating cycles ≥ 100  
 Recommended torque 1.5 Nm

**Environmental Data**

Temperature range -55 °C to +125 °C operating temperature  
 Thermal shock IEC 61169-1 9.4.4  
 Vibration IEC 61169-1 9.3.3 and IEC 60068-2-64  
 Shock IEC 61169-1 9.3.14  
 Degree of protection (mated pair) IEC 60529, IP68 24h / 1m  
 RoHS compliant

**Tooling**

N/A

**Suitable Cables**

N/A

**Weight**

17.5 g/pc

While the information has been carefully compiled to the best of our knowledge, nothing is intended as representation or warranty on our part and no statement herein shall be construed as recommendation to infringe existing patents. In the effort to improve our products, we reserve the right to make changes judged to be necessary.

For the installation of the electrotechnical equipment, particular electrotechnical expertise is required.



Draft	Date	Approved	Date	Rev.	Engineering change number	Name	Date
F. Fraunhofer	15.12.2017	Chr. Janßen	02.02.2021	b00	20-1927	B. Wollitzer	02.02.2021
Rosenberger Hochfrequenztechnik GmbH & Co. KG P.O.Box 1260 D-84526 Tittmoning Germany <a href="http://www.rosenberger.com">www.rosenberger.com</a>						Tel. : +49 8684 18-0 Email : <a href="mailto:info@rosenberger.com">info@rosenberger.com</a>	
						Page 2 / 2	