

RECOMMENDED BOARD LAYOUT

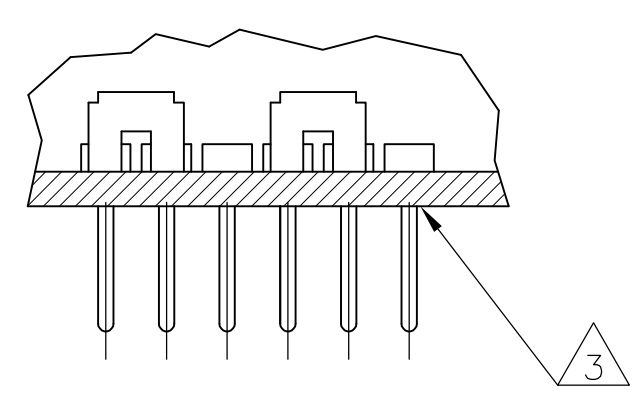
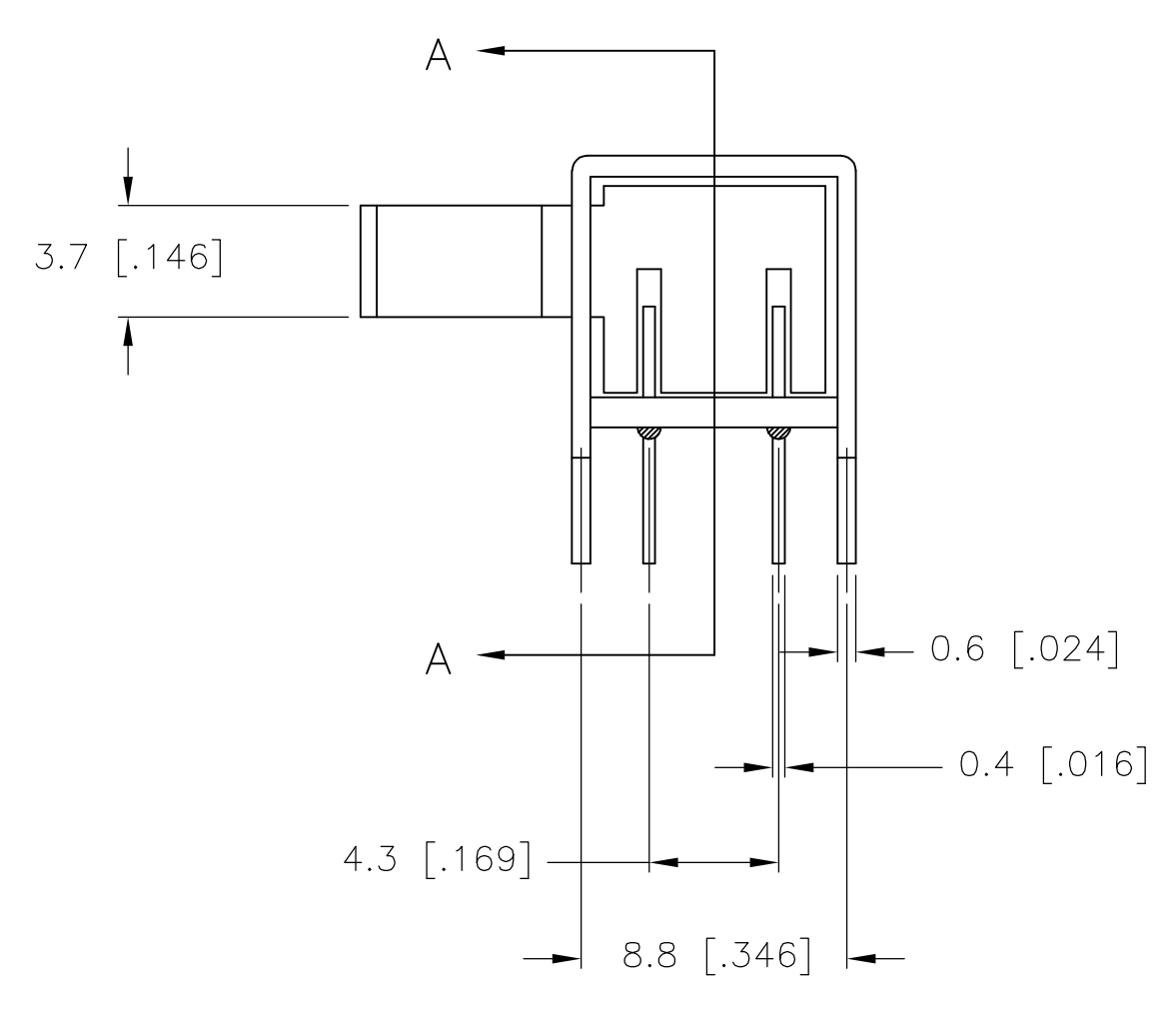

SECTION A-A

SPECIFICATIONS  
MAKE-BEFORE-BREAK

MATERIALS:  
 ACTUATOR- POM, UL94HB BLACK  
 TERMINAL BOARD- PHENOLIC LAMINATED SHEET, UL94HB, NATURAL  
 FRAME- STEEL, NICKEL PLATE  
 TERMINAL/FIXED CONTACT- COPPER ALLOY, GOLD OR SILVER OVER NICKEL PLATE  
 MOVING CONTACT- COPPER ALLOY, GOLD OR SILVER OVER NICKEL PLATE  
 DETENT BALL- STEEL  
 COIL SPRING- GALVANIZED SPRING WIRE  
 SEAL- EPOXY

ELECTRICAL:  
 CONTACT RATING- .4VA@20VDC OR PEAK AC (GOLD); 300mA@125V AC (SILVER)  
 INITIAL CONTACT RESISTANCE- 30 milliohm max.  
 FINAL CONTACT RESISTANCE- 100 milliohm max. (AFTER TEST)  
 INSULATION RESISTANCE- 1,000 Megohms min.  
 DIELECTRIC STRENGTH- 500V RMS@SEA LEVEL  
 LIFE EXPECTANCY- 15,000 CYCLES MIN.

MECHANICAL:  
 ACTUATION FORCE- 600+/-300 GRAMS  
 TRAVEL- 2.0 +/-0.50 (.079 +/-0.020)

ENVIRONMENTAL:  
 OPERATING TEMPERATURE- -20 TO +85 DEGREES C  
 STORAGE TEMPERATURE- -40 TO +100 DEGREES C  
 RESISTANCE TO SOLDER HEAT PER 109-202, CONDITION B  
 SOLDERABILITY PER EIA-364-52, CLASS 2, CATEGORY 1, 95% MIN COVERAGE

NOTES:

1. COUNTRY OF ORIGIN AND TE LOGO LOCATED APPROXIMATELY AS SHOWN
2. LL MATERIALS AND FINISHES SHALL COMPLY WITH EU DIRECTIVE 2002/95/EC OF 27JAN2003 (ROHS)
3. ANTI SOLDER WICK SEAL AT TERMINAL TO BOARD INTERFACE
4. ALL PERFORMANCE TESTING WAS DONE IN ACCORDANCE TO TE CONNECTIVITY SPECIFICATION 102-2469

1825265-2	MSS4200R04	GOLD	1 TO 2 4 TO 5 7 TO 8 10 TO 11	2 TO 3 5 TO 6 8 TO 9 11 TO 12
1825265-1	MSS4200R04	SILVER	1 TO 2 4 TO 5 7 TO 8 10 TO 11	2 TO 3 5 TO 6 8 TO 9 11 TO 12
PART NO.	T&B PART NO.	PLATING		

TERMINALS CONNECTED WHEN SLIDE IS IN POSITION SHOWN.

THIS DRAWING IS A CONTROLLED DOCUMENT.

DWN	R BROWN	21DEC05		TE Connectivity	
CHK	M SARVER	21DEC05		NAME	
APPD	M SARVER	21DEC05	PRODUCT SPEC		SLIDE SWITCH, MSS 4200R SERIES
APPLICATION SPEC			SIZE	CAGE CODE	DRAWING NO
MATERIAL			WEIGHT	A1	00779
FINISH			SCALE		4:1
CUSTOMER DRAWING			SHEET		1 OF 1
			REV		A3