

REVISIONS

NOTE:

- 1 MOUNTING: 2x SLOT 5x10mm
- 2 TERMINATION CABLES: UL APPROVED FEP CABLES FOR THE TERMINATIONS, BASED ON THE RESISTOR CURRENT RATING (SEE CHART BELOW) WITH E5 RING TERMINALS

CURRENT RATING	CABLE SIZE USED
≤15A	16 AWG
>15A & ≤25A	14 AWG
>25A & ≤35A	12 AWG

3 FOR FURTHER INFORMATION SEE DATA SHEET FOR CJP SERIES OF ALUMINIUM HOUSED RESISTOR

P	LTR	DESCRIPTION	DATE	DWN	APVD
	A	INITIAL DRAWING RELEASE	27MAY2022	KS	AP
	A1	NEW PN ADDED TO SCHEDULE	06OCT2022	DM	AP

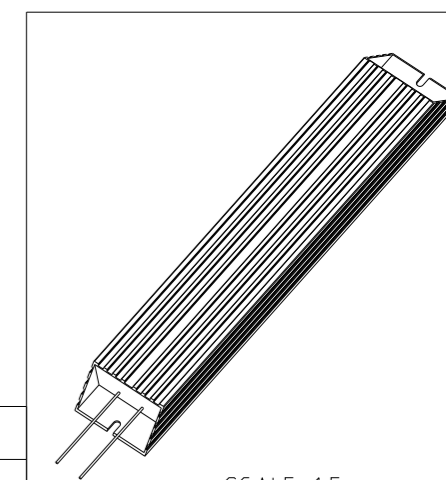
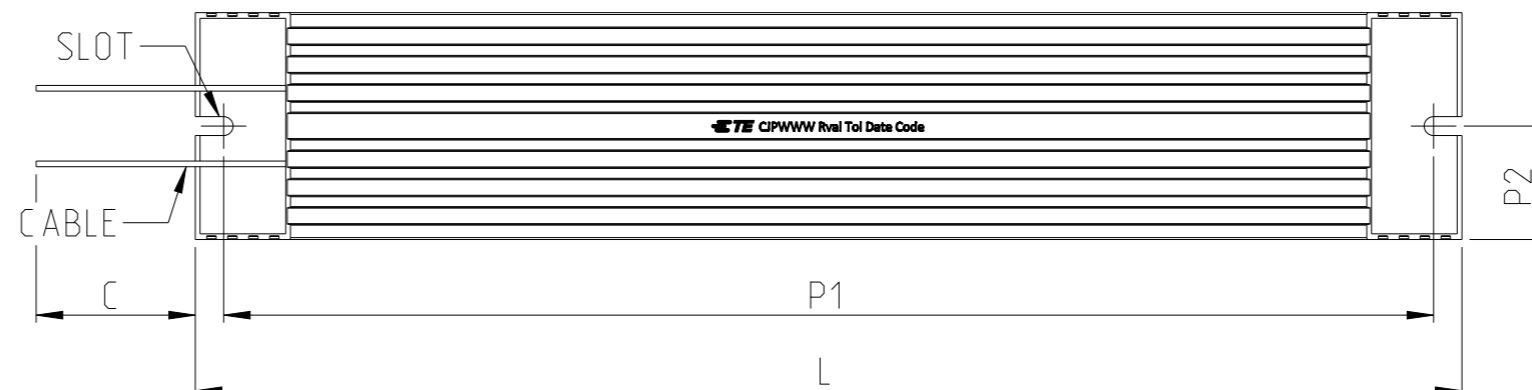
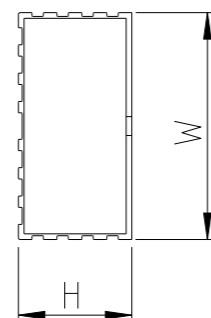

PART NUMBER	L	W	H	C	P1	P2
CJP500	335	60	30	290	320	30

THIS DRAWING IS A CONTROLLED DOCUMENT.

DWN: KARTHIK S 27MAY2022
 CHK: ALLAN P 27MAY2022
 APVD: ALLAN P 27MAY2022



DIMENSIONS: mm	TOLERANCES UNLESS OTHERWISE SPECIFIED:	PRODUCT SPEC
	0 PLC ± 1 PLC ±0.5 2 PLC ±0.13 3 PLC ±0.013 4 PLC ±0.0001 ANGLES ±	-
MATERIAL	FINISH	APPLICATION SPEC
-	-	-
		WEIGHT
		-

NAME			ALUMINIUM ENCLOSED RESISTOR CJP500 SERIES		
SIZE	CAGE CODE	DRAWING NO	RESTRICTED TO		
A3	00779	C=2176510	-		

REVISIONS

P	LTR	DESCRIPTION	DATE	DWN	APVD
	-	SEE SHEET 1	-	-	-

SCHEDULE

TCPN	PRODUCT NUMBER	MATERIAL DESCRIPTION	PART STATUS
2176510-1	C JP500J1R5J	C JP 500W 1R5 5% LEAD	PRODUCTION
2176510-2	C JP500J1R8J	C JP 500W 1R8 5% LEAD	PRODUCTION
2176510-3	C JP500J2R2J	C JP 500W 2R2 5% LEAD	PRODUCTION
2176510-4	C JP500J2R7J	C JP 500W 2R7 5% LEAD	PRODUCTION
2176510-5	C JP500J3R3J	C JP 500W 3R3 5% LEAD	PRODUCTION
2176510-6	C JP500J3R9J	C JP 500W 3R9 5% LEAD	PRODUCTION
2176510-7	C JP500J4R7J	C JP 500W 4R7 5% LEAD	PRODUCTION
2176510-8	C JP500J5R6J	C JP 500W 5R6 5% LEAD	PRODUCTION
2176510-9	C JP500J6R8J	C JP 500W 6R8 5% LEAD	PRODUCTION
1-2176510-0	C JP500J8R2J	C JP 500W 8R2 5% LEAD	PRODUCTION
1-2176510-1	C JP500J10RJ	C JP 500W 10R 5% LEAD	PRODUCTION
1-2176510-2	C JP500J12RJ	C JP 500W 12R 5% LEAD	PRODUCTION
1-2176510-3	C JP500J15RJ	C JP 500W 15R 5% LEAD	PRODUCTION
1-2176510-4	C JP500J18RJ	C JP 500W 18R 5% LEAD	PRODUCTION
1-2176510-5	C JP500J22RJ	C JP 500W 22R 5% LEAD	PRODUCTION
1-2176510-6	C JP500J27RJ	C JP 500W 27R 5% LEAD	PRODUCTION
1-2176510-7	C JP500J33RJ	C JP 500W 33R 5% LEAD	PRODUCTION
1-2176510-8	C JP500J39RJ	C JP 500W 39R 5% LEAD	PRODUCTION
1-2176510-9	C JP500J47RJ	C JP 500W 47R 5% LEAD	PRODUCTION
2-2176510-0	C JP500J56RJ	C JP 500W 56R 5% LEAD	PRODUCTION

SCHEDULE

TCPN	PRODUCT NUMBER	MATERIAL DESCRIPTION	PART STATUS
2-2176510-1	C JP500J68RJ	C JP 500W 68R 5% LEAD	PRODUCTION
2-2176510-2	C JP500J82RJ	C JP 500W 82R 5% LEAD	PRODUCTION
2-2176510-3	C JP500J100RJ	C JP 500W 100R 5% LEAD	PRODUCTION
2-2176510-4	C JP500J120RJ	C JP 500W 120R 5% LEAD	PRODUCTION
2-2176510-5	C JP500J150RJ	C JP 500W 150R 5% LEAD	PRODUCTION
2-2176510-6	C JP500J180RJ	C JP 500W 180R 5% LEAD	PRODUCTION
2-2176510-7	C JP500J220RJ	C JP 500W 220R 5% LEAD	PRODUCTION
2-2176510-8	C JP500J270RJ	C JP 500W 270R 5% LEAD	PRODUCTION
2-2176510-9	C JP500J330RJ	C JP 500W 330R 5% LEAD	PRODUCTION
3-2176510-0	C JP500J390RJ	C JP 500W 390R 5% LEAD	PRODUCTION
3-2176510-1	C JP500J470RJ	C JP 500W 470R 5% LEAD	PRODUCTION
3-2176510-2	C JP500J560RJ	C JP 500W 560R 5% LEAD	PRODUCTION
3-2176510-3	C JP500J680RJ	C JP 500W 680R 5% LEAD	PRODUCTION
3-2176510-4	C JP500J820RJ	C JP 500W 820R 5% LEAD	PRODUCTION
3-2176510-5	C JP500J1K0J	C JP 500W 1K0 5% LEAD	PRODUCTION
3-2176510-6	C JP500J1K2J	C JP 500W 1K2 5% LEAD	PRODUCTION
3-2176510-7	C JP500J1K5J	C JP 500W 1K5 5% LEAD	PRODUCTION
3-2176510-8	C JP500J1K8J	C JP 500W 1K8 5% LEAD	PRODUCTION
3-2176510-9	C JP500J1R0J	C JP 500W 1R0 5% LEAD	PRODUCTION

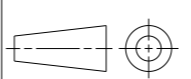
THIS DRAWING IS A CONTROLLED DOCUMENT.		DWN KARTHIK S 27MAY2022	 TE Connectivity	
DIMENSIONS: mm		CHK ALLAN P 27MAY2022		
TOLERANCES UNLESS OTHERWISE SPECIFIED:		APVD ALLAN P 27MAY2022	NAME ALUMINIUM ENCLOSED RESISTOR C JP500 SERIES	
		PRODUCT SPEC -	RESTRICTED TO -	
MATERIAL -		FINISH -	APPLICATION SPEC -	SCALE 1:1
		WEIGHT -	SIZE A3	CAGE CODE 00779
			DRAWING NO C=2176510	SHEET 2 OF 2
			CUSTOMER DRAWING	REV A1