

RECOMMENDED P.C.B.HOLE PATTERN.

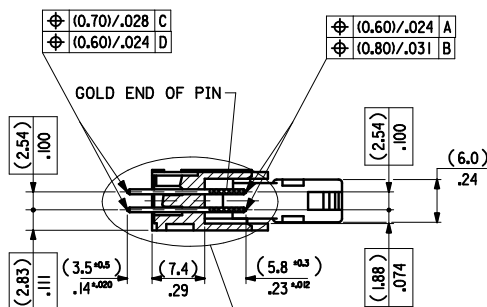

SECTION F-F

SEE DETAIL A.

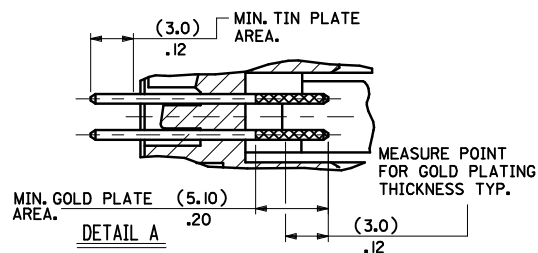

DIMENSIONS FOR SELECTIVE PLATING'S, SCALE 4:1

(78.74)/3.100	(86.34)/3.400	(90.52)/3.564	(96.62)/3.804	(100.74)/3.966	90663-0641	64
(73.66)/2.900	(81.26)/3.200	(85.44)/3.364	(91.54)/3.604	(95.66)/3.766	90663-0601	60
(60.69)/2.400	(68.56)/2.700	(72.74)/2.864	(78.84)/3.104	(82.96)/3.266	90663-0501	50
(48.26)/1.900	(55.86)/2.200	(60.04)/2.364	(66.14)/2.604	(70.26)/2.766	90663-0401	40
(40.64)/1.600	(48.24)/1.900	(52.42)/2.064	(58.52)/2.304	(62.64)/2.466	90663-0341	34
(35.56)/1.400	(43.16)/1.700	(47.34)/1.864	(53.44)/2.104	(57.56)/2.266	90663-0301	30
(30.48)/1.200	(38.08)/1.500	(42.26)/1.664	(48.36)/1.904	(52.48)/2.066	90663-0261	26
(22.86)/.900	(30.46)/1.200	(34.64)/1.364	(40.74)/1.604	(44.86)/1.766	90663-0201	20
(17.78)/.700	(25.38)/1.000	(29.56)/1.164	(35.66)/1.404	(39.78)/1.566	90663-0161	16
(15.24)/.600	(22.84)/.900	(27.02)/1.064	(33.12)/1.304	(37.24)/1.466	90663-0141	14
(10.16)/.400	(17.76)/.700	(21.94)/.864	(28.04)/1.104	(32.16)/1.266	90663-0101	10
A	B	C	D	E	ENG. NO. GSI PLATING	NO. OF CRTS.

NOTES

- MATERIAL
HEADER : GLASS FILLED POLYESTER (UL 94V0), COLOUR - WHITE.
PINS : COPPER ALLOY □ SIZE (0.635)/.025 .
LEVER : GLASS FILLED POLYESTER (UL 94V0), COLOUR - BLACK.
- PLATING
90663-0**1, (1um)/.039um MIN. NICKEL UNDERPLATE, CONTACT AREA
GSI PLATING (0.1um)/.004um MIN. GOLD, SOLDER AREA (3um)/.118um MIN. TIN.
- PRODUCT SPECIFICATION NO. : PS-99020-0015
- COLOUR VARIATION MAY BE VISABLE ON THE SURFACES OF THE HEADER.
- RECOMMENDED PCB THICKNESS 1.6mm

REMOVED REFS TO COLOR STAMP EC NO: E2011-0063 DRWN: JCONNOR 2010/08/12 CHKD: 2010/08/25 APPR: ELOLAN 2010/08/30	QUALITY SYMBOLS ▽=0 ▽=0	GENERAL TOLERANCES (UNLESS SPECIFIED)	DIMENSION STYLE MM/IN	SCALE 2:1	DESIGN UNITS METRIC	THIRD ANGLE PROJECTION
		4 PLACES ± --- ± --- 3 PLACES ± --- ± .008 2 PLACES ± 0.20 ± .008 1 PLACE ± 0.20 ± --- ANGULAR ± 2 °	mm INCH DRAWN BY DWASZKIEWI CZ 2006/12/13 DATE 2006/12/13 CHECKED BY JDENNEHY DATE 2006/12/12 APPROVED BY JDENNEHY DATE 2006/12/13	TITLE QF50 SRD HDR VT W/O POL RIBS W/ELV .1AU	molex MOLEX INCORPORATED	
DRAFT WHERE APPLICABLE MUST REMAIN WITHIN DIMENSIONS		SEE CHART		DOCUMENT NO. SDA-90663E		SHEET NO. 9 OF 9
THIS DRAWING CONTAINS INFORMATION THAT IS PROPRIETARY TO MOLEX INCORPORATED AND SHOULD NOT BE USED WITHOUT WRITTEN PERMISSION						