



V3S100-2AABAAB

Visionary-T

3D MACHINE VISION

SICK
Sensor Intelligence.

Ordering information



Type	Part no.
V3S100-2AABAAB	1086943

Other models and accessories → www.sick.com/Visionary-T

Illustration may differ



Detailed technical data

Features

Task	Presence inspection Measuring, 3D Collision awareness
Technology	3D snapshot, image analysis
Product category	Configurable, programmable, Streaming, pre-calibrated
Working distance	0.5 m ... 60 m ¹⁾
Example field of view	7 m x 5.3 m ²⁾
Detection angle	69° x 56°
Angular resolution	0.39° x 0.38°
Light source	Internal lighting LED, invisible, infrared, 850 nm
LED class	
Factory calibrated	✓
Grayscale measurements	✓

¹⁾ Radial distance for targets having 100% remission.

²⁾ See table for individual values.

Mechanics/electronics

Connection type	M12 8-pin Gigabit Ethernet, X-coded M12 17-pin (voltage supply/data), system plug, digital IOs (24 V)
Supply voltage	24 V DC ¹⁾
Power consumption	≤ 22 W, Typical (without digital I/Os)
Peak current	3 A
Enclosure rating	IP67
Protection class	III

¹⁾ (+/-20 %), < 2,5 ms integration time
(+/-15 %), > 2,5 ms integration time.

²⁾ Without cooling fins.

Housing color	Blue, black
Weight	1.4 kg, without cooling fins
Dimensions (L x W x H)	162 mm x 93 mm x 78 mm ²⁾
Mounting	Any or can be determined by raster

¹⁾ (+/-20 %), < 2,5 ms integration time
(+/-15 %), > 2,5 ms integration time.

²⁾ Without cooling fins.

Performance

Pixel count	176 px x 144 px
Repeatability	≥ 2 mm, at 1 m range ≥ 7 mm, at 7 m range ¹⁾
On delay	< 15 s
Response time	< 66 ms
Integrated application	Data stream with the option of filtering the data

¹⁾ See table for individual values.

Interfaces

Ethernet	✓
Function	Complete data stream combining distance, intensity, and confidence values in one snapshot plus device control
Data transmission rate	60 Mbit/s, communication interface Gigabit Ethernet (TCP/IP)
Configuration software	SOPAS ET, Telegram interface, API (Java), Web-Interface
Digital input	2
Digital output	4
Optical indicators	2 status LEDs

Ambient data

Electromagnetic compatibility (EMC)	EN 61000-6-2:2005-08, EN 61000-6-4:2007-01
Shock load	EN 60068-2-27:2009
Vibration load	EN 60068-2-6, EN 60068-2-64
Ambient operating temperature	0 °C ... +45 °C, without cooling fins ¹⁾
Storage temperature	-20 °C ... +70 °C
Ambient light immunity	< 50 klx, Sunlight

¹⁾ The ambient operating temperature is reduced by 5 °C in speed mode to 40 °C.

General notes

Note	All relevant materials for commissioning (instructions, drivers, examples, software, API) can be found in the Downloads tab under "Other downloads".
-------------	--

Classifications

ECl@ss 5.0	27310205
ECl@ss 5.1.4	27310205
ECl@ss 6.0	27310205
ECl@ss 6.2	27310205
ECl@ss 7.0	27310205

ECl@ss 8.0	27310205
ECl@ss 8.1	27310205
ECl@ss 9.0	27310205
ECl@ss 10.0	27310205
ECl@ss 11.0	27310205
ETIM 5.0	EC001820
ETIM 6.0	EC001820
ETIM 7.0	EC001820
ETIM 8.0	EC001820
UNSPSC 16.0901	43211731

Dimensional drawing (Dimensions in mm (inch))

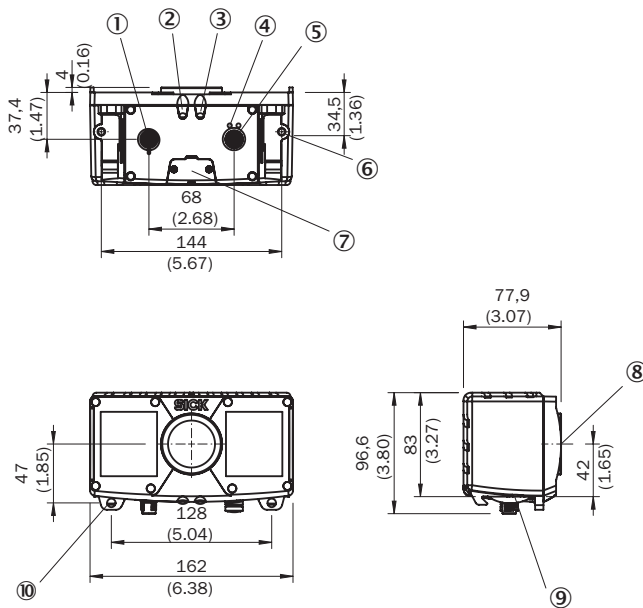

- ① Power connection / digital inputs and outputs / service
- ② Device display
- ③ Application status display
- ④ Ethernet status display
- ⑤ Ethernet connection
- ⑥ M6 blind tapped holes, 7 mm deep (2 x), for mounting
- ⑦ Service interface
- ⑧ Optical axis
- ⑨ Interface bracket
- ⑩ Bracket mounting (accessories)

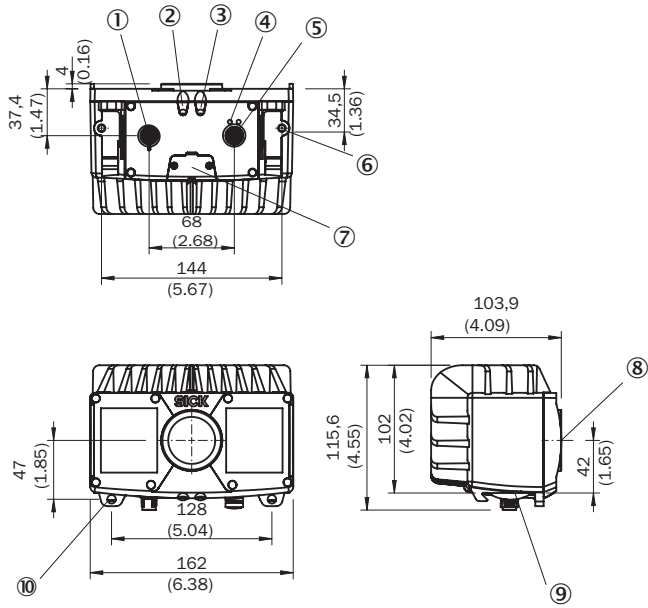

- ① Power connection / digital inputs and outputs / service
- ② Device display
- ③ Application status display
- ④ Ethernet status display
- ⑤ Ethernet connection
- ⑥ M6 blind tapped holes, 7 mm deep (2 x), for mounting
- ⑦ Service interface
- ⑧ Optical axis
- ⑨ Interface bracket
- ⑩ Bracket mounting (accessories)

Field of view

Detection zone and field of view ($\Delta x \times \Delta y$)

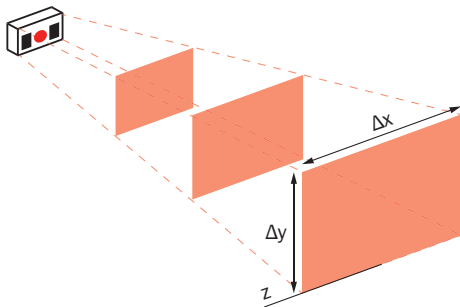

Working distance absolute (z)	Range (Δx)	Range (Δy)
0,5 m	0,7 m	0,5 m
1,0 m	1,4 m	1,0 m
1,5 m	2,1 m	1,6 m
2,0 m	2,8 m	2,1 m
3,0 m	4,1 m	3,1 m
4,0 m	5,5 m	4,2 m
5,0 m	6,8 m	5,3 m
10,0 m	13,7 m	10,6 m

Working distance absolute (z)	Range (Δx)	Range (Δy)
15,0 m	20,6 m	15,9 m
20,0 m	27,4 m	21,2 m
40,0 m	54,9 m	42,5 m

Working distance radial/absolute

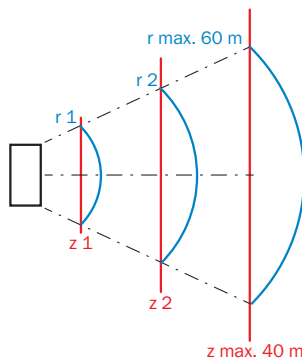

Absolute accuracy (z-axis) and repeatability at 10 % and 100 % remission and without background light (central detection zone)

Working distance radial (r)	Measurement accuracy (100% remission)	Repeatability (1 σ - 100% remission)	Measurement accuracy (10% remission)	Repeatability (1 σ - 10% remission)
0,5 m	± 15 mm	± 2 mm	± 15 mm	± 2 mm
1,0 m	± 15 mm	± 2 mm	± 15 mm	± 3 mm
2,0 m	± 15 mm	± 2 mm	± 20 mm	± 6 mm
3,0 m	± 15 mm	± 3 mm	± 35 mm	± 10 mm
4,0 m	± 20 mm	± 3 mm	± 50 mm	± 20 mm
5,0 m	± 25 mm	± 4 mm	± 50 mm	± 25 mm
7,0 m	± 35 mm	± 7 mm	-	-
10,0 m	± 50 mm	± 15 mm	-	-
15,0 m	± 50 mm	± 30 mm	-	-
20,0 m	± 50 mm	± 50 mm	-	-

Connection type

Gigabit Ethernet

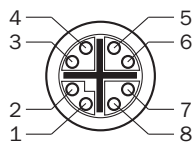

M12, 8-pin female connector, X-coded (Gigabit Ethernet)

- ① TRD0_P
- ② TRD0_N
- ③ TRD1_P
- ④ TRD1_N
- ⑤ TRD3_P
- ⑥ TRD3_N
- ⑦ TRD2_P
- ⑧ TRD2_N

Digital I/O

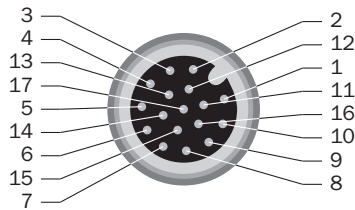





M12, 17-pin male connector

- ① GND – reference mass
- ② 24 V DC –30% to +20% – supply voltage
- ③ CAN L – reserved, not implemented. Do not connect to VCC!
- ④ CAN H – reserved, not implemented. Do not connect to VCC!
- ⑤ TD+ (RS-422/485) Host – reserved, not implemented. Do not connect to VCC!
- ⑥ TD- (RS-422/485) Host, TxD (RS-232), Host – reserved, not implemented. Do not connect to VCC!
- ⑦ TxD (RS-232), Aux – service only
- ⑧ RxD (RS-232), Aux – service only
- ⑨ SENS GND – GND for electrically decoupled inputs
- ⑩ SENS IN1 – switch input, electrically decoupled
- ⑪ RD+ (RS-422) Host – reserved, not implemented. Do not connect to VCC!
- ⑫ RD- (RS-422/485) Host, RxD (RS-232), Host – reserved, not implemented. Do not connect to VCC!
- ⑬ INOUT 1 – programmable digital I/O
- ⑭ INOUT 2 – programmable digital I/O
- ⑮ SENS IN2 – switch input, electrically decoupled
- ⑯ INOUT 3 – programmable digital I/O
- ⑰ INOUT 4 – programmable digital I/O

Recommended accessories

Other models and accessories → www.sick.com/Visionary-T

	Brief description	Type	Part no.
Plug connectors and cables			
	Head A: female connector, M12, 17-pin, straight, A-coded Head B: Flying leads Cable: Power, serial, CAN, digital I/Os, suitable for 2 A, Changed color coding of the flying leads, PE-X, shielded, 3 m	YF2ASD-030XXXXLECX	2070425
	Head A: female connector, M12, 17-pin, straight, A-coded Head B: Flying leads Cable: Power, serial, CAN, digital I/Os, suitable for 2 A, Changed color coding of the flying leads, PE-X, shielded, 5 m	YF2ASD-050XXXXLECX	2070426
	Head A: female connector, M12, 17-pin, straight, A-coded Head B: male connector, M12, 17-pin, straight, A-coded Cable: Power, serial, CAN, digital I/Os, suitable for 2 A, shielded, 3 m	YM2A8D-030XXXF2A8D	6051194
	Head A: male connector, M12, 8-pin, straight, X-coded Head B: male connector, RJ45, 8-pin, straight Cable: Ethernet, Gigabit Ethernet, PUR, halogen-free, shielded, 2 m	YM2X18-020EG1MRJA8	2106258
	Head A: male connector, M12, 8-pin, straight, X-coded Head B: male connector, RJ45, 8-pin, straight Cable: Ethernet, Gigabit Ethernet, PUR, halogen-free, shielded, 5 m	YM2X18-050EG1MRJA8	2106259
Terminal and alignment brackets			
	1 piece, Bracket including clamps and screws, metal, Bracket including clamps and screws	Mounting set (2-part) incl. clamps and screws	2077710

	Brief description	Type	Part no.
	1 piece, 2x clamps and 2x screws, metal, 2 clamps and 2 screws	2x clamps, 2x screws	2077709

Recommended services

Additional services → www.sick.com/Visionary-T

	Type	Part no.
<p>Warranty extensions</p> <ul style="list-style-type: none"> • Product area: Identification solutions, machine vision, Distance sensors, Detection and ranging solutions • Range of services: The services correspond to the scope of the statutory manufacturer warranty (SICK general terms and conditions of purchase) • Duration: Five-year warranty from delivery date. 	Extended warranty for a total of five years from delivery date	1680671

SICK AT A GLANCE

SICK is one of the leading manufacturers of intelligent sensors and sensor solutions for industrial applications. A unique range of products and services creates the perfect basis for controlling processes securely and efficiently, protecting individuals from accidents and preventing damage to the environment.

We have extensive experience in a wide range of industries and understand their processes and requirements. With intelligent sensors, we can deliver exactly what our customers need. In application centers in Europe, Asia and North America, system solutions are tested and optimized in accordance with customer specifications. All this makes us a reliable supplier and development partner.

Comprehensive services complete our offering: SICK LifeTime Services provide support throughout the machine life cycle and ensure safety and productivity.

For us, that is “Sensor Intelligence.”

WORLDWIDE PRESENCE:

Contacts and other locations –www.sick.com