

THIS COPY IS PROVIDED ON A RESTRICTED BASIS AND IS NOT TO BE USED IN ANY WAY DETRIMENTAL TO THE INTERESTS OF PANDUIT CORP.

PART NUMBER	MAT'L	"A" HEIGHT +/- .06	IMPRINT AREA "B" +/- .06	VERTICAL REPEAT "C" +/- .06	LABELS PER ROW	STANDARD PKG. QTY.
S100X250TAT	GMT1	2.50 [63.5]	1.00 [25.4]	2.75 [69.85]	4	5000
S100X400TAT		4.00 [101.6]		4.25 [108.0]		2500
S100X075VATY	GMV16 OR GMV17	0.75 [19.0]	0.25 [6.35]	1.00 [25.4]		5000
S100X125VATY		1.25 [31.8]	0.38 [9.53]	1.50 [38.1]		
S100X150VATY		1.50 [38.1]	0.50 [12.7]	1.80 [45.7]		
S100X160VATY		1.60 [40.64]	0.80 [20.32]	1.90 [48.26]		1000
S100X225VATY		2.25 [57.2]	0.75 [19.0]	2.50 [63.5]		5000
S100X250VATY		2.50 [63.50]	1.00 [25.4]	2.75 [69.85]		
S100X400VATY	7	4.00 [101.6]	1.00 [25.4]	4.25 [108.0]		2500
S100X650VATY		6.50 [165.1]		1.50 [38.1]		6.75 [171.4]

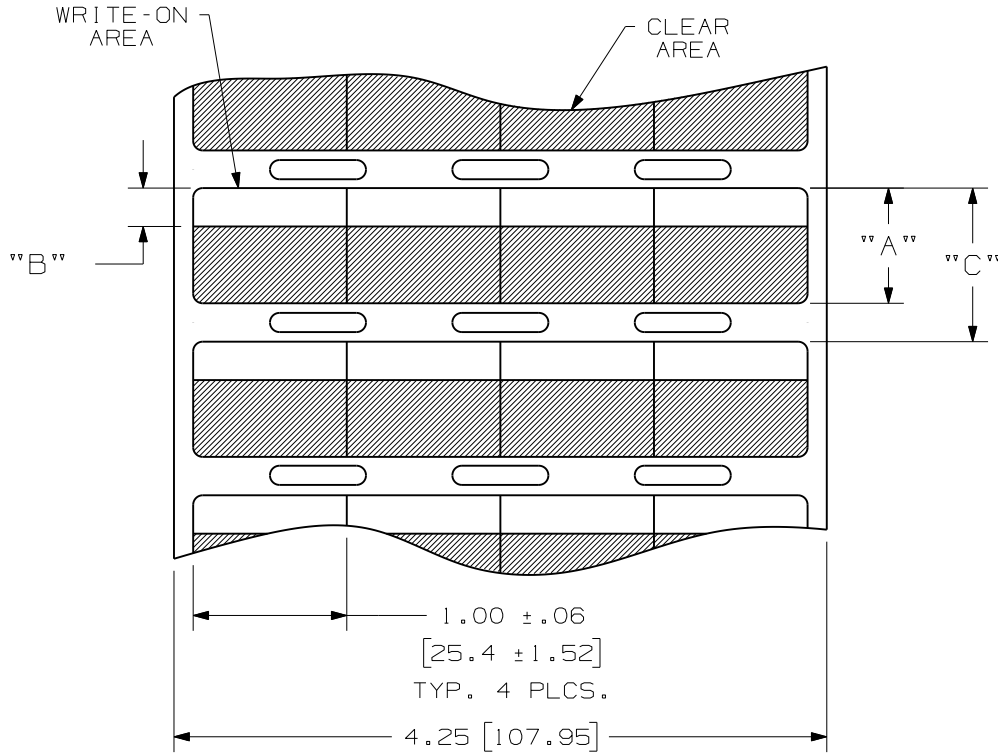

NOTE:
1. MILLIMETERS ARE IN [].

CAD FILENAME/LAYERS 100472BU_DC_C10196/09H

REV	DATE	BY	CHK	DESCRIPTION	ECN	R	CUST	SUP	DATE	CHK'D	MAT'L	SCALE	DWG
7	10/25/11	RVU		"GMV16 OR GMV17" WAS "GMV".	6548	R						NTS	A
6	12/1/08	RVU	MSAD	S100X160VATY, CHANGE STD. PKG. QTY. FROM 5000 TO 1000.	5616	R							
5	9/8/08	RVU	DAPE	REMOVED P/N: S100X075VAT, S100X125VAT, S100X150VAT, S100X225VAT, S100X400VAT, AND S100X650VAT. INCORRECT TOLERANCES. REMOVE NOTES 2, CHG. B TO A.	5539	R							
4	10/22/07	RVU	DWY	ADDED +/- .031, +/- .045, +/- .070, +/- 0.10 ON COLUMN "A" HEIGHT, IMPRINT AREA "B", AND VERTICAL REPEAT "C".	5186	R							
3	5/29/07	RVU	DWY	ADDED NEW P/N, S100X250TAT, S100X400TAT, S100X160VATY, AND S100X250VATY. REVISED MAT'L.	5021	R							
2	1-8-07	RVU	DWY	REVISED TOLERANCE.	4830	R							
1	12-19-06	RVU	DWY	ADDED RoHS COMPLIANT PANDUIT PART NUMBERS WITH SUFFIX "Y" AND MATERIAL GMV.	4671	R							
0	9-1-06	RVU	DWY	DRAWING RELEASE.									
										DRAWN BY	SEE TABLE		DWG
										DATE	9-1-06		
										CHK'D		C10196	A

PANDUIT CORP. TINLEY PARK, ILLINOIS

CUSTOMER DRAWING
OPTIMUM SELF-LAM. S100X***VATY, TAT
THERMAL TRANSFER PRINTABLE LABELS

UNLESS OTHERWISE SPECIFIED,
DIMENSIONAL TOLERANCES ARE:
(.X) ± .1 (.XXX) ± .025
(.XX) ± .06 ANGLES ±

UNLESS OTHERWISE SPECIFIED,
ALL DIMENSIONS ARE GIVEN
IN INCHES, THIRD ANGLE PROJECTION.

SCALE NTS

DRAWING NO. C10196

DWG SIZE A