

01.1

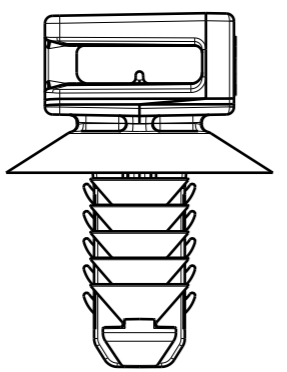

Mount
Delivery Condition: Unassembled Set

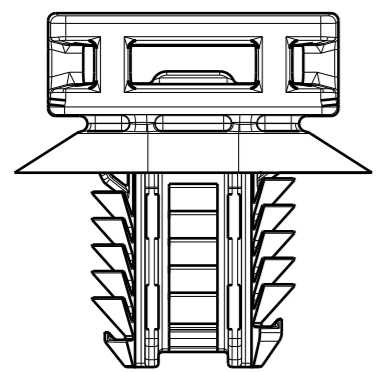
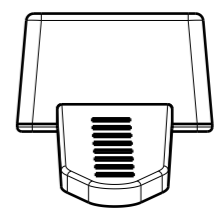
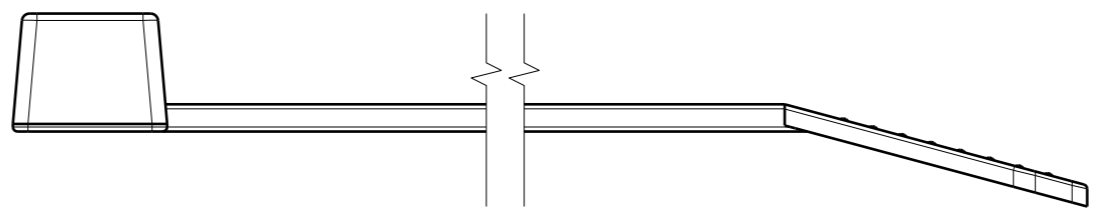
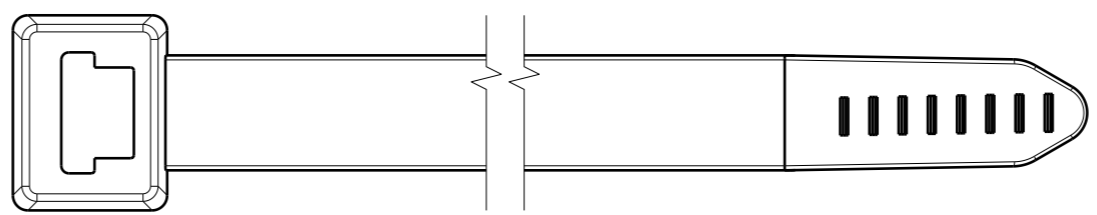

Cable Tie
Delivery Condition: Unassembled Set

- Notes:
1. Material: See chart
 2. Material color: See chart
 3. Maximum percent regrind permissible: 25%
 4. Max allowable flash to be: 0.5mm
 5. Max allowable mismatch to be: 0.1mm

Global Part Description	Bundle Range	Cable Ties			Mount		
		Drawing	Material	Color	Drawing	Material	Color
T120RSADFTOVAL-SET-PA66HIRHSUV-BK	5 to 105	CT2120003CST	PA66HIRHSUV	Black	20-0891-001-CSU	PA66HIRHSUV	Black

Revision Level			Revision Record		The copyright of this drawing is reserved by HellermannTyton.	Drawn	Date (YYYY/MM/DD)	Title T120 Standard Cable Tie with Oval Fir Tree Mount	Scale
Drawing	State	Part	016270	 All drawing revisions are stored in CAD PDM database		Duncan	2020/11/09		Drawing-No 20-0891-101-CSU
01.1	Design Release	-			Approved	Van Hulst	2020/11/09	Global Project Number 20-0891	
Changed	Date (YYYY/MM/DD)				Units	HellermannTyton www.HellermannTyton.com		Format	
Duncan	2021/01/04				mm			Sheet	1 / 1
Approved	Date (YYYY/MM/DD)								
Karabon	2021/01/29								

