

AOYUE[®]

Int9378

***Pro-Series
Intelligent***

Soldering Station

Instruction Manual

Thank you for purchasing the Aoyue Int9378 Soldering Station.
Please read the manual before using the unit.
Keep manual in accessible place for future reference.

Manufacturer:

AOYUE INTERNATIONAL LIMITED

Jishui Industrial Zone, Nantou, Zhongshan City,

Guangdong Province, P.R.China

<http://www.aoyue.com>

This manual is designed to familiarize and instruct the technician with the proper operation and maintenance of the equipment. The "Care and Safety Precautions" section explains the hazards of using any type of soldering or reworking device. Please read carefully and observe the guidelines in order to maximize usage and minimize the risk of injury or accidents .

Soldering Iron Stand

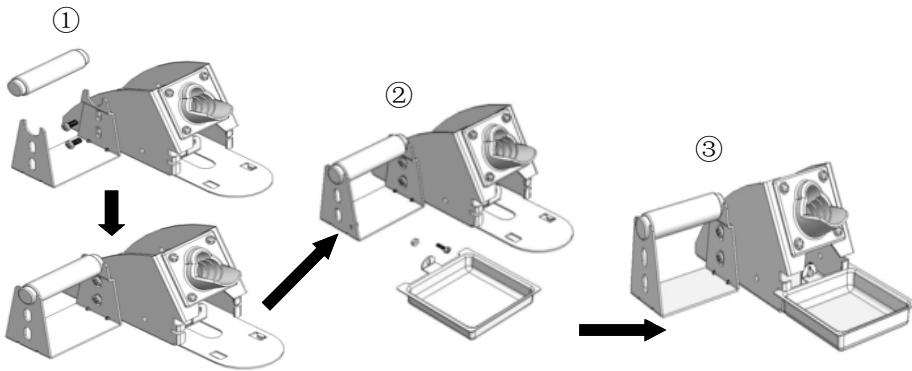

Conical Type

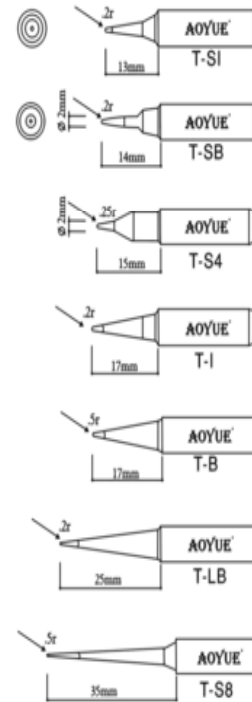

Bevel Type

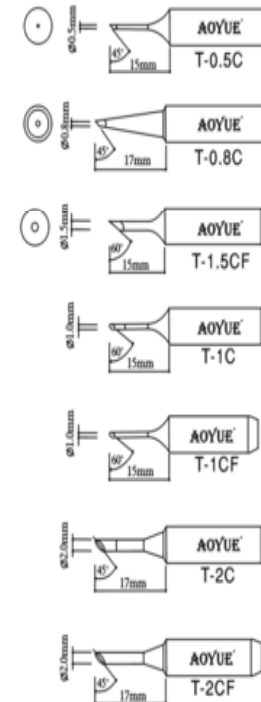

Chisel Type

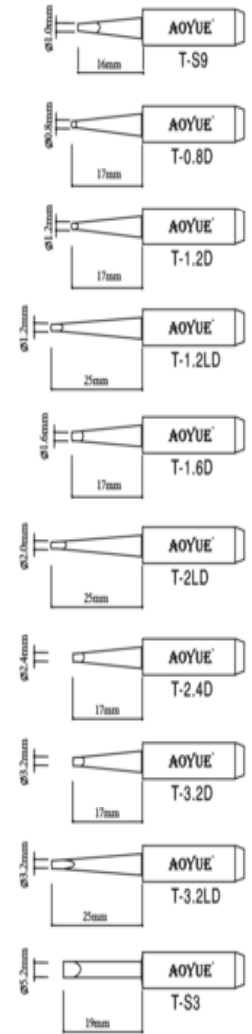

Sharp-Bent Type

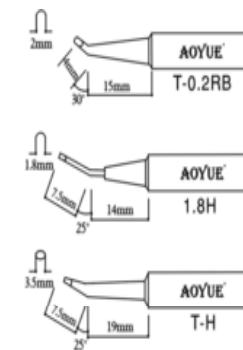

Blade Type

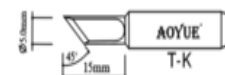

Slot Type

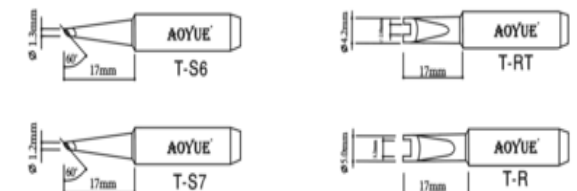

Suitable for all AOYUE soldering irons except lead free composite tip series, induction series and 938

BASIC TROUBLESHOOTING GUIDE

PROBLEM 1: THE UNIT HAS NO POWER

1. Check if the unit is switched ON.
2. Check the fuse. Replace with the same type if fuse is blown.
3. Check the power cord and make sure there are no disconnections.
4. Verify that the unit is properly connected to the power source.

PROBLEM 2: TEMPERATURE IS NOT INCREASING

CASE 1: Tip temperature does not increase, display shows the word "Err1"

SOLUTION:

The solder Iron is not connected or its connection is loosely connected to the main station. Plug the solder iron firmly and lock into position.

CASE 2: Solder Iron is properly connected, display still shows "Err1"

SOLUTION:

The heating element may have been damaged. Replace heating element. Or check the wirings of the solder iron pen.

CASE 3: Solder Iron is properly connected, Display shows low temperature levels then switches to "Err2"

SOLUTION:

The heating element is damaged. Replace heating element. Or check the wirings of the solder iron pen.

PROBLEM 3: SOLDER IRON TIP IS OVERHEATING

Description: Solder iron tip is getting too hot.

SOLUTION:

Digital offset settings might be adjusted too high causing overheat protection. Repeat the steps in page 8 under **DIGITAL OFFSET**.

Ensure that the maximum temperature is only at 480C.

PROBLEM 4: OTHER PROBLEMS NOT MENTIONED IN THIS DOCUMENT

SOLUTION: Contact authorized service station.

TABLE OF CONTENTS

Product Description	4
Package Inclusion	4
Safety Precautions	5
Specifications	6
Functions and Features	6
Control Panel Guide	6
Operating Guidelines	7— 12
Menu structure	7
Initial Procedures	7
Temperature Control	8
Digital Offset	8
Quick Jump Feature	9
Sleep Function	10
System Lock	11
Temperature Scale	12
Power LED	12
Care and Maintenance	13
Basic Troubleshooting Guide	14
Replacement Soldering Iron Tips.....	15

PRODUCT DESCRIPTION

The Aoyue Int9378 Pro-Series is a high performance multi-tool station having up to 75 watts of heating power. It can be equipped with a variety of tools such as a micro tweezer, a sculpting tool, a WQ-composite Iron, T-series soldering Iron, LED soldering iron. Each tool is intelligently recognized by the station and quickly set the appropriate settings for the tool. All tools feature quick heating ceramic heater for fast response and heat recovery.

Intelligent functions and features are available such as digital offset, auto wake function, auto sleep function, auto tool recognition, System lock-out , quick jump, Temperature Scale selection, LED lamp control and auto sleep.

PACKAGE INCLUSION

1 unit Int9378 Pro-Series Main Station

1 pc. Soldering Iron

1 pc. 2660 Soldering Iron Stand**

1 pc. Power Cord

1 pc. Instruction Manual

**** Kindly refer to soldering iron stand installation on page 2 for parts and instructions.**

CARE AND MAINTENANCE

Tip Temperature :

High temperature shortens tip life and may cause thermal shock to components. Always use the lowest possible temperature when soldering. Standard temperature settings are 350 to 400 degrees Celsius.

Cleaning :

Always clean the soldering tip before use to remove any residual solder or flux adhering to it. Use a clean and moist cleaning sponge. Contaminants on the tip have many detrimental effects including reduced heat conductivity which contribute to poor soldering performance.

After usage:

Always clean the tip and coat it with fresh solder after use. This guards against oxidation and pro-longs tip life.

System Care:

Never allow the unit to stay idle at high temperature for extended periods. Utilize the automated sleep feature to conserve energy, prolong tip and heating element life. If unit will not be used for long periods it is advised to power down the unit and unplug from the mains.

Inspecting and cleaning the tip:

- ◆ Set the temperature to 250°C.
- ◆ When the temperature stabilizes, clean the tip and check its condition. If the tip is badly worn or deformed, replace it.
- ◆ If the solder plated part of the tip is covered with black oxide, apply fresh solder containing flux and clean the tip again. Repeat until all the oxide is removed then coat the tip with fresh solder.
- ◆ Never file the tip to remove oxide.
- ◆ Remaining oxides such as the yellow discoloration on the tip shaft can be removed with isopropyl alcohol.

OPERATING GUIDELINES

G. TEMPERATURE SCALE

The displayed temperature can be toggled between the centigrade scale or the Fahrenheit scale.

To switch between the two scales follow these procedures:

1. With the unit turned On, Press and hold the SET button to enter the system configuration mode.
 2. Repeatedly press the "SET" button until "C°" or "F°" is displayed. This denotes that we are now configuring temperature scale settings.
 3. "C°" indicates that the current system scale is Centigrade. "F°" denotes the selected temperature scale is the Fahrenheit scale. Press the increase or decrease button to select between the two temperature scales.
 4. To save the temperature scale settings, repeatedly press the SET button until the display shows the word "SAVE". Press the increase button to save and exit from the system configuration mode.
- ◆ The temperature display would change according to the scale selected. A suffix "F" / "###F" indicates the Fahrenheit scale, while "C" / "###C" indicated the Centigrade scale.

H. POWER LED

For tools with LED capabilities only.

To switch between the On and Off:

1. With the unit turned On, Press and hold the SET button to enter the system configuration mode.
2. Repeatedly press the "SET" button until "POFF" is displayed. This denotes that we are now configuring Power LED settings. Press up and down button to select between ON and OFF.
3. "OFF" indicates that the LED is turned OFF. "ON" indicates LED is turned on.
4. To save the settings, repeatedly press the SET button until the display shows the word "SAVE". Press the increase button to save and exit from the system configuration mode.

Note: During system configuration mode if it is decided that the recently changed setting should not be saved into system memory, repeatedly press the set button until the display shows the word "Cncl" (cancel). Press the decrease button to exit system configuration mode without saving the most recent changes made.

SAFETY PRECAUTIONS



CAUTION: Improper usage can cause serious injury to personnel and/or damage to equipment and work area. For your own safety, please observe the following precautions.

- Check each component after opening the package to make sure everything is in good condition. If there are any suspected damage, do not use the item and report the issue to your vendor.
- Turn OFF the main power switch and unplug the device from power source when moving the device.
- Do not strike or subject the main unit (and all its components) to physical shock. Use carefully to avoid damage to any part.
- Handle with care.
 - Never drop or sharply jolt the unit.
 - Contains delicate parts that may break if the unit is dropped.
- Make sure the equipment is always grounded. Always connect power to a grounded receptacle.
- Temperature may reach as high as 480°C when switched ON.
 - Do not use the device near flammable gases, paper and other flammable materials.
 - Do not touch heated parts, which can cause severe burns.
 - Do not touch metallic parts near the tip.
- Disconnect the plug from the power source if the unit will not be used for a long period.
 - Turn off power during breaks, if possible.
- Use only genuine replacement parts.
 - Turn off power and let the unit cool down before replacing any part.
- The unit may produce a small amount of smoke and unusual odor during initial usage. This is normal and should not yield any negative result when reworking.
- Soldering process produces smoke — use on well ventilated places.
- Do not alter the unit, specifically the internal circuitry, in any manner.

SPECIFICATION

Voltage Input :	available in 110V / 220V
Station Dimensions:	110(w) x98 (h) x 155 (d) mm
Weight:	1.5Kg
Power Consumption:	Up to 75W (60W with default Iron)
Temperature Range:	200°C - 480°C
Heating Element	Ceramic heater
Output voltage:	24V

FUNCTIONS and FEATURES

- Microprocessor-controlled ESD safe Soldering station.
- Multi-tool system: tweezers, sculpting pen, composite tip, others.
- Intelligent station automatically recognized plugged tool.
- Compatible with Lead free applications.
- High power heating element for fast heat recovery.
- Large display with digital controls.
- Programmable sleep timer, with auto sleep and wake up function.
- Digital offset.
- System-lock out feature.
- Quick jump to favorite settings.
- Switch between Centigrade and Fahrenheit scale.

CONTROL PANEL GUIDE

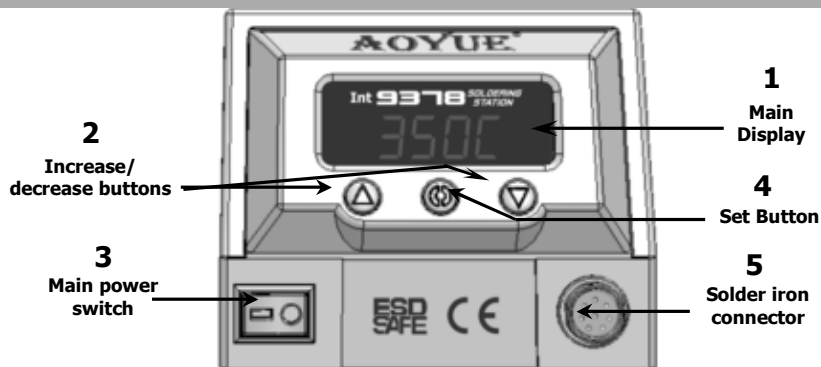

OPERATING GUIDELINES

3. "t000" indicates that the sleep function is currently turned off. To adjust the timer settings press the increase or decrease button. Sleep timer is adjustable from 2 to 60 minutes.
4. To save the settings, repeatedly press the SET button until the display shows the word "SAVE". Press the decrease button to save and exit from the system configuration mode.

F. SYSTEM LOCK

The System lock feature disables adjustment to both temperature and system configuration. The display will show "SAFE" when system lock feature is enabled. To disengage system lock press and hold all three buttons for more than 15 seconds.

To activate the system lock feature:

1. With the unit turned On, Press and hold the SET button to enter the system configuration mode.
2. Repeatedly press the "SET" button until "LOFF" is displayed. This denotes that we are now configuring the system lock setting.
3. "LOFF" indicates that the system lock function is currently disabled. To engage the system lock press the decrease button to switch the lock feature to "LOn".
4. To save and activate the system lock settings, repeatedly press the SET button until the display shows the word "SAVE". Press the decrease button to save and exit from the system configuration mode.
5. The display would show the word "SAFE", indicating system lock is enabled.

When the system lock feature is enabled changing of temperature and system settings are blocked. The system lock must be disengaged to re-enable access to the system.

To de-activate the system lock:

1. With the unit turned On, press and hold the INCREASE, SET and DECREASE button for more than 15 seconds.
2. The display would switch from "SAFE" to the set temperature display when system lock has been disengaged.

OPERATING GUIDELINES

6. To save the settings, repeatedly press the SET button until the display shows the word "SAVE". Press the decrease button to save and exit from the system configuration mode.
7. The two quick jump settings has now been configured and can be accessed by simultaneously pressing the "INCREASE" and "SET" button for the first Quick jump level. And simultaneously pressing the "DECREASE" and "SET" button will access the second quick jump level.

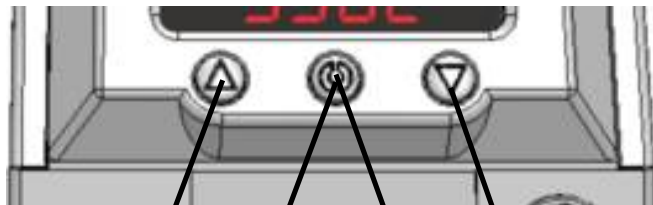

Quick Jump #1
b350 (default)

Quick Jump #2
C430 (default)

Increase + Set

Set + Decrease

E. SLEEP FUNCTION

The Soldering Iron is equipped with a vibration sensor. When the soldering iron has been left unmoved the system would begin the count down of the sleep timer. The suffix will change to a small letter "d" to indicate that the system is preparing to enter sleep mode. The display will show four dashes "- - - -" to indicate the system has entered sleep mode. To wake the system, simply lift up the soldering iron or push any control buttons.

Sleep timer is configurable via the following method:

1. With the unit turned On, Press and hold the SET button to enter the system configuration mode.
2. Repeatedly press the "SET" button until a number with prefix "t" or "t000" is displayed. This denotes that we are now configuring the sleep timer setting.

OPERATING GUIDELINES

REMINDERS:

- ◆ Make sure the equipment is placed on a flat stable surface and all the heat-generating components placed on their respective holders or stands.
- ◆ Ensure all function switches are in the OFF position.
- ◆ Ensure all terminal connections are properly secured.



IMPORTANT: Please refer to the **CONTROL PANEL GUIDE** page for buttons and display panel directory.

Menu Structure:

c013	Current tool detected.
A000	Digital offset value (-70 to +70).
b350	Quick Jump Settings 1 (200– 480).
C450	Quick Jump Settings 2 (200– 480).
t 60	Sleep timer currently set to 60 minutes (0-60 minutes).
L0FF	Lock out feature.
°C	Centigrade or Fahrenheit selection
P0FF	Power LED for LED tool .
SAVE	Save settings and exit.
Encl	Do not save settings and exit.

OPERATING GUIDELINES

A. INITIAL PROCEDURES

1. Insert the power cord into the receptacle at the back of the station.
2. Plug the power cord into a grounded wall socket. The station is protected against electrostatic discharge and must be grounded for full efficiency.
3. Be sure the power switch is OFF before connecting or disconnecting the soldering iron cord. Failure to do so may result in damage to the circuit board.
4. Follow instructions on soldering iron stand assembly guide.
5. Attach the soldering iron to the 8-pin output at the bottom right area of the station.
6. Place soldering iron to the soldering iron stand as shown .
7. Dampen the sponge with water and squeeze excess water before using. The tips maybe damaged when used with dry sponge.
8. The unit is now ready for use.

B. TEMPERATURE CONTROL

1. Turn the power ON.
2. The display would show a number between 200 to 480 indicating the set temperature.
3. The display would then switch to showing the actual temperature.
4. Adjust desired set temperature by pressing the increase/decrease buttons.
5. While adjusting the set temperature the display would show the current adjusted set temperature, after a few seconds the display will revert to showing the actual temperature.
6. Temperature control range is from 200C to 480C.

C. DIGITAL OFFSET

The unit is provided with a digital offset feature for tip calibration.

To calibrate the tip temperature:

1. Set to desired working temperature.
2. Measure the tip temperature through an external temperature reader with a thermocouple as its sensor. Ensure the external temperature reader's sensor and the solder iron's tip can keep good physical contact. Wait for the display to reach the set temperature , then allow the tip to idle at the sensor for 60 seconds for proper temperature measurement.
3. Press and hold the SET button to enter the system configuration mode. Wait for the display to change to [01] meaning current tool 01.

OPERATING GUIDELINES

4. Press the set button again to scroll to the Digital offset function. The display shows a number with an "A" as its prefix. This denotes that we are now configuring the digital offset of the system. A display like "A000" indicates that the digital offset is currently set at neutral.
5. Press the increase and decrease button to adjust the digital offset. A negative number denotes a negative offset and a positive number denotes a positive offset. Adjust the offset number until the external temperature sensor reading is equal to our set temperature.
6. Adjust the offset number until the external temperature sensor reading is equal to our set temperature.
7. Repeatedly press the SET button until the display shows the word "SAVE". Press the idcrease button to save and exit from the system configuration mode.
8. The tip has now been properly calibrated.
9. Saved settings are stored into memory and will remain in effect unless changed by the user.

D. QUICK JUMP FEATURE

The system has two configurable quick jump settings. The quick jump features enables the user to easily jump to a predefined temperature level. The two most frequently used temperature level must first be saved into system memory. A simple push of two button will automatically jump to these preset temperature level.

To configure these two quick jump temperature level:

1. Press and hold the SET button to enter the system configuration mode.
2. Repeatedly press the SET button until the display shows a number with "b" as its prefix. This denotes that we are now configuring the first quick jump setting.
3. Select your desired quick jump temperature level by pressing the increase or decrease button.
4. To adjust the second quick jump level, repeatedly press the "SET" button until a number with a prefix "C" is displayed. This denotes that we are now configuring the second quick jump setting.
5. Select your desired quick jump temperature level by pressing the increase or decrease button.