

ignion[™]

Your innovation.
Accelerated.

Most integrated antenna for any IoT design

APPLICATION NOTE
TRIO mXTEND[™] (NN03-310)

TRIO mXTEND™: THE ANTENNA DESIGNED TO FIT ALL IoT SIZES

- **Product:** TRIO mXTEND™ NN03-310
- **Dimensions :** 30.0 mm x 3.0 mm x 1.0 mm
- **Frequency regions:** 698-960 MHz and 1710-2690 MHz



The IoT world and its IoT devices are a priority now for many companies. This is not a concept anymore, lots of devices become a reality and they need **wireless connectivity** at **many different frequency** bands as quick as possible and in the easiest way.

Sometimes **designers don't know the size or form factor of the future device** and moreover they don't even know the frequency bands to cover. So, **which antenna is the right selection? Do I need to wait till the last minute to choose the antenna?** The **answer is no**, you don't need to wait if you use Virtual Antenna® technology, the technology where **the component is always the same** regardless of the size or form factor of the printed circuit board. Having one antenna component for all sizes gives you the freedom to start with the antenna from the beginning, therefore optimizing the antenna to the limit, and if you need to change finally your design, the component remains the same because you change the desired frequency bands by only adjusting the matching network.

Within this application note you can check how the **TRIO mXTEND™** chip antenna component, the ultra slim, off the shelf component of only 1.0 mm height, can fit different board sizes by only adjusting its matching network. It also works in multiple frequency regions at the same time thanks to its modular, multiband and multi-port configuration.

Feel free to design your ideal new IoT platform, the antenna choice is only one.

TABLE OF CONTENTS

1. PRODUCT DESCRIPTION NN03-310	4
2. ONE ANTENNA, MANY DEVICES	5
2.1. PERFORMANCE IN DIFFERENT PCB SIZES	5
2.2. VSWR AND EFFICIENCY	6
2.3. MATCHING NETWORK	7

1. PRODUCT DESCRIPTION NN03-310

The market for the Internet of Things demanding cellular connectivity continues to grow and the expanding diversity of IoT devices means that product configurations are endless. For this application note we have tested the TRIO mXTEND[™] chip antenna component (NN03-310) performance when mounted onto various sized ground planes. We show the impact of ground plane size on performance in order to provide the most relevant results for those who design IoT devices of various dimensions.

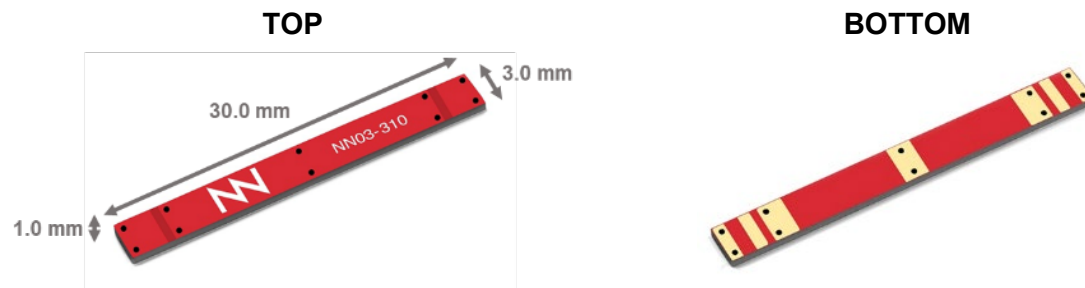

Material: The TRIO mXTEND[™] chip antenna component is built on glass epoxy substrate.

APPLICATIONS

- Handsets
- Smartphones
- Tablets
- Laptop PCs
- Smart Meters
- Smart City/Building/Home
- Trackers
- Fleet management
- IoT Devices
- Modules

BENEFITS

- High efficiency
- Small size
- Cost-effective
- Easy-to-use (pick and place)
- Multiband behaviour (worldwide standards)
- Off-the-Shelf Standard Product (no customization is required)

The TRIO mXTEND[™] chip antenna component has been specifically designed for providing the major level of flexibility to operate any required frequency band inside any wireless device. TRIO mXTEND[™] chip antenna component is capable of operating the main mobile communication standards 2G, 3G, 4G (698-960MHz and 1710-2690MHz), the main short range wireless bands such as Bluetooth and Wi-Fi (2400-2500MHz and 4900-5875MHz), as well as the Global Navigation Satellite Systems (GNSS) such as GPS, Galileo, GLONASS, and Beidou (1561 MHz, 1575 MHz and 1598-1606 MHz), all through the same antenna component.

The TRIO mXTEND[™] chip antenna component offers the flexibility to be tuned at the frequency regions of interest through the proper adjustment of the matching network. This characteristic provides an important benefit since removes the need of including different antenna parts inside the same wireless device for operating different communication standards, thus reducing considerably the integration complexity while saving costs. The results gathered herein presents how the matching network should be configured for operating the main cellular communication standards when regarding different Printed Circuit Board (PCB) sizes.

2. ONE ANTENNA, MANY DEVICES

2.1. PERFORMANCE IN DIFFERENT PCB SIZES

For demonstration purposes, the performance of the TRIO mXTEND™ chip antenna component is measured in different evaluation boards within the 698-960 MHz and 1710-2690 MHz frequency range, as used in many cellular IoT devices. Please note that the TRIO mXTEND™ is able to cover a much wider range of communication standards such as GNSS and WiFi/BT through the same antenna package.

If your IoT device needs to operate in some additional standard or in some particular bands inside the 698MHz to 3800MHz frequency range you are welcome to contact support@ignion.io for assistance.

Each PCB board in the following set-up integrates a UFL cable to connect the TRIO mXTEND™ chip antenna component with a SMA connector so that VSWR and antenna efficiency can be tested. The following results cover a wide scope of PCB sizes (length (A) and width (C)) (Figure 1), ranging from 142mm x 60mm down to 50mm x 50mm.

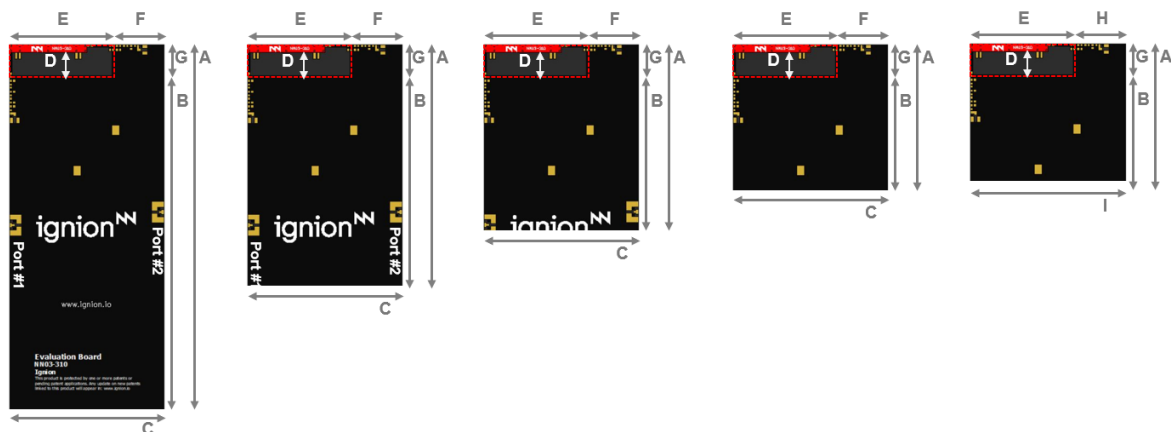

Figure 1 – Evaluation boards with different PCB dimensions that provide operation from 698 MHz to 960 MHz and from 1710 MHz to 2690 MHz.

Measure	mm
A	142 - 50
B	130 - 38
C	60
D	9
E	40
F	20
G	12
H	10
I	50

Tolerance: ±0.2 mm

D: Distance between the TRIO mXTEND™ chip antenna component and the ground plane.

Material: The Evaluation Board is built on FR4 substrate. Thickness is 1 mm.

Clearance area: 40mm x 12mm (ExG)

2.2. VSWR AND EFFICIENCY

VSWR (Voltage Standing Wave Ratio) and Total Efficiency versus Frequency (GHz).

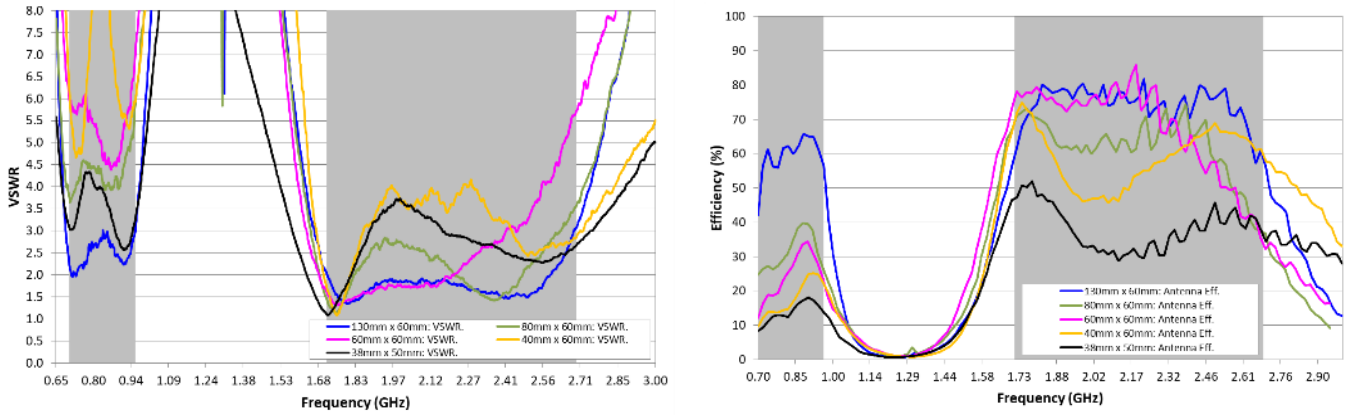

Figure 2 – VSWR and Total Efficiency for the 698 – 960 MHz and 1710 – 2690 MHz frequency range. Graph dimensions in the legend refer to BxC (Figure 1).

Ground Plane dimensions (B x C)	LFR (698 – 960 MHz)					HFR (1710 – 2690 MHz)				
	η_a 698 MHz	η_a 960 MHz	Min	Max	Av. η_a	η_a 1710 MHz	η_a 2690 MHz	Min	Max	Av. η_a
130mm x 60mm	42.0	56.5	42.0	65.7	60.1	59.1	58.5	57.3	8.8	74.3
80mm x 60mm	24.2	25.5	24.2	37.9	31.2	63.0	38.0	38.0	72.7	62.5
60mm x 60mm	12.2	24.0	12.0	34.4	25.0	69.9	41.8	41.1	85.9	68.9
40mm x 60mm	9.6	22.1	9.6	25.1	17.8	69.2	59.6	45.7	74.9	58.8
38mm x 50mm	8.4	13.8	8.4	18.0	14.0	46.9	36.1	28.7	52.0	38.2

Table 1 – Total efficiency (%) comparison considering the different PCB sizes (Figure 1).

2.3. MATCHING NETWORK

The matching network design and value components for each device and PCB size is provided here. While the antenna component and matching network design and topology remains the same, the value of the components will be adapted to every PCB size for an optimum performance. The specs of a Ignion standard product are measured in a reference evaluation board, to isolate the antenna performance from other system elements. However, when incorporating into real designs, nearby components such as LCD's, batteries, covers and connectors may affect the antenna performance. For this reason, placing pads compatible with 0402 and 0603 SMD components for a matching network as close as possible to the feeding point is highly recommended. The matching network should be implemented in the ground plane area rather than the clearance area, this will provide a degree of freedom for tuning the TRIO mXTEND™ chip antenna component once the design is finished, taking into account all elements of the system (batteries, displays, covers, etc.).

Please notice that different devices with different ground planes and different components nearby the TRIO mXTEND™ chip antenna component may require a fine tuning of the matching networks. To ensure optimal results, the use of high Q and tight tolerance components is highly recommended (Murata components).

If you need assistance to design your matching network beyond this application note, please contact support@ignion.io, or if you are designing a **different device size** or a **different frequency band**, we can assist you in less than 24 hours. Please, try our free-of-charge¹ [Antenna Intelligence Cloud](#), which will get you a complete design report including a custom matching network for your device in 24h¹. Additional information related to NN's range of R&D services is available at: <https://ignion.io/rdservices/>

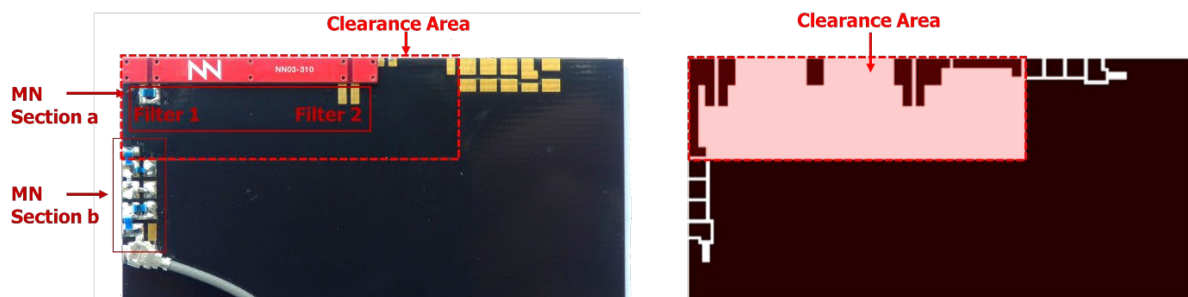

Figure 3 – Matching network distribution

¹ See terms and conditions for a free Antenna Intelligence Cloud service in 24h at: <https://www.ignion.io/antenna-intelligence/>

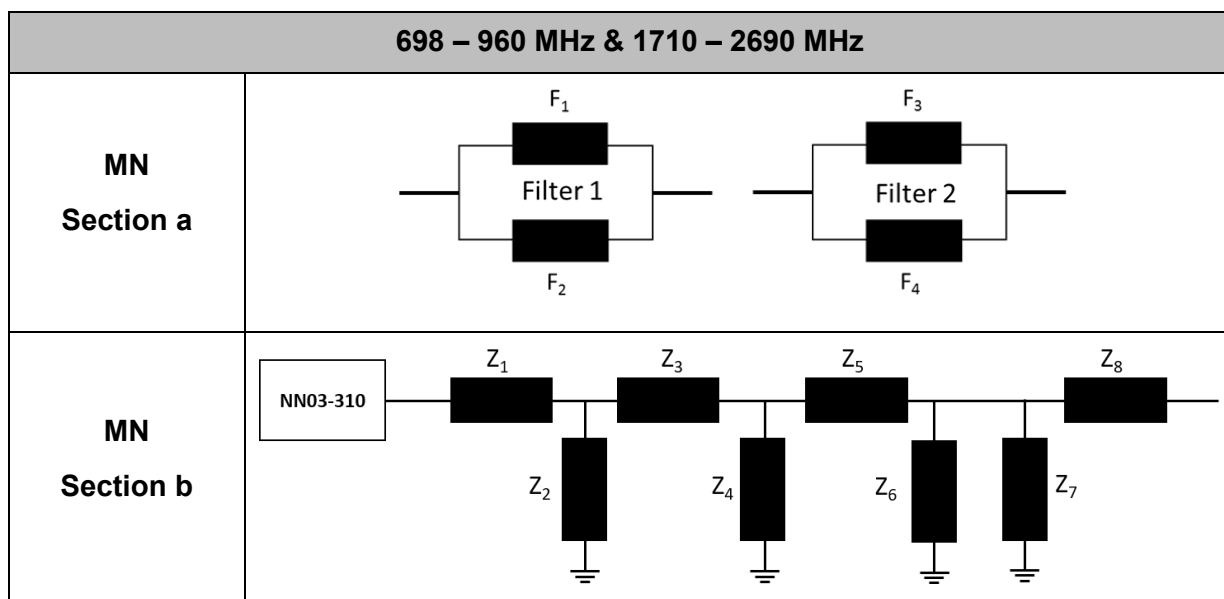

Figure 4 – Topology of matching network mounted for the different solutions.

Dimensions (B x C)	F ₁	F ₂	F ₃	F ₄	Z ₁	Z ₂	Z ₃	Z ₄	Z ₅	Z ₆	Z ₇	Z ₈
130 mm x 60 mm	15nH	0.3pF	Empty	Empty	2.2nH	8.6nH	2.2pF	1.0pF	0Ω	10nH	0.36pF	3.0nH
80 mm x 60 mm	13nH	0.4pF	0Ω	Empty	3.7nH	9.1nH	2.2pF	0.9pF	0Ω	13nH	0.36pF	1.8nH
60 mm x 60 mm	12nH	0.5pF	0Ω	Empty	2.2nH	8.4nH	2.2pF	1.0pF	0Ω	10nH	0.4pF	0Ω
40 mm x 60 mm	12nH	0.5pF	0Ω	Empty	2.2nH	8.4nH	2.2pF	0.7pF	0Ω	10nH	0.3pF	2.2nH
38 mm x 50 mm	12nH	0.5pF	0Ω	Empty	2.2nH	8.4nH	2.2pF	0.6pF	0Ω	10nH	0.3pF	0Ω

Table 2 – Values of the components for each different solution.

Value		Part Number
F1	15 nH	LQW18AN15NG80
	13 nH	LQW18AN13NG80
	12 nH	LQW18AN12NG10
F2	0.3 pF	GJM1555C1HR30WB01
	0.4 pF	GJM1555C1HR40WB01
	0.5 pF	GJM1555C1HR50WB01
F3	-	Empty
	0 Ω	-
F4	-	Empty
Z1	2.2 nH	LQW18AN2N2C80
	3.7 nH	LQW15AN3N7G80
	2.2 nH	LQW15AN2N2G80
Z2	8.6 nH	LQW15AN8N6G80
	9.1 nH	LQW18AN9N1G80
	8.4 nH	LQW18AN8N4G80
Z3	2.2 pF	GJM1555C1H2R2WB01
Z4	1.0 pF	GJM1555C1H1R0WB01
	0.9 pF	GJM1555C1HR90WB01
	0.7 pF	GJM1555C1HR70WB01
	0.6 pF	GJM1555C1HR60WB01

Z5	0 Ω	-
Z6	10 nH	LQW18AN10NG80
	13 nH	LQW18AN13NG80
Z7	0.36 pF	GJM1555C1HR36WB01
	0.4 pF	GJM1555C1HR40WB01
	0.3 pF	GJM1555C1HR30WB01
Z8	3.0 nH	LQW18AN3N0C80
	1.8 nH	LQW15AN1N8C00
	0 Ω	-
	2.2 nH	LQW15AN2N2G80

Table 3 – Values and part numbers of the components used for the matching networks for the cases with dimensions 130mm x 60mm, 80mm x 60mm, 60mm x 60mm, 40mm x 60mm and 38mm x 50mm.

Ignion products are protected by [Ignion patents](#).

All information contained within this document is property of Ignion and is subject to change without prior notice. Information is provided “as is” and without warranties. It is prohibited to copy or reproduce this information without prior approval.

Ignion is an ISO 9001:2015 certified company. All our antennas are lead-free and RoHS compliant.

ISO 9001: 2015 Certified



ignion[™]

Your innovation.
Accelerated.

Contact:
support@ignion.io
+34 935 660 710

Barcelona

Av. Alcalde Barnils, 64-68 Modul C, 3a pl.
Sant Cugat del Vallés
08174 Barcelona
Spain

Shanghai

Shanghai Bund Centre
18/F Bund Centre, 222 Yan'an Road East,
Huangpu District
Shanghai, 200002
China

New Delhi

New Delhi, Red Fort Capital Parsvnath Towers
Bhai Veer Singh Marg, Gole Market,
New Delhi, 110001
India

Tampa

8875 Hidden River Parkway
Suite 300
Tampa, FL 33637
USA