

Cable connector - UC-17S1N8AT0DU - 1606605

Please be informed that the data shown in this PDF Document is generated from our Online Catalog. Please find the complete data in the user's documentation. Our General Terms of Use for Downloads are valid (<http://phoenixcontact.com/download>)

Cable connector, angled, shielded: yes, Screw locking, M23, No. of pos.: 17, type of contact: Socket, Crimp connection



The figure shows the 12-pos. product version



Key Commercial Data

Packing unit	8 pc
GTIN	 4 046356 260640
GTIN	4046356260640

Technical data

Environmental Product Compliance

	Lead 7439-92-1
China RoHS	Environmentally Friendly Use Period = 50
	For details about hazardous substances go to tab "Downloads", Category "Manufacturer's declaration"

Drawings

Cable connector - UC-17S1N8AT0DU - 1606605

Dimensional drawing

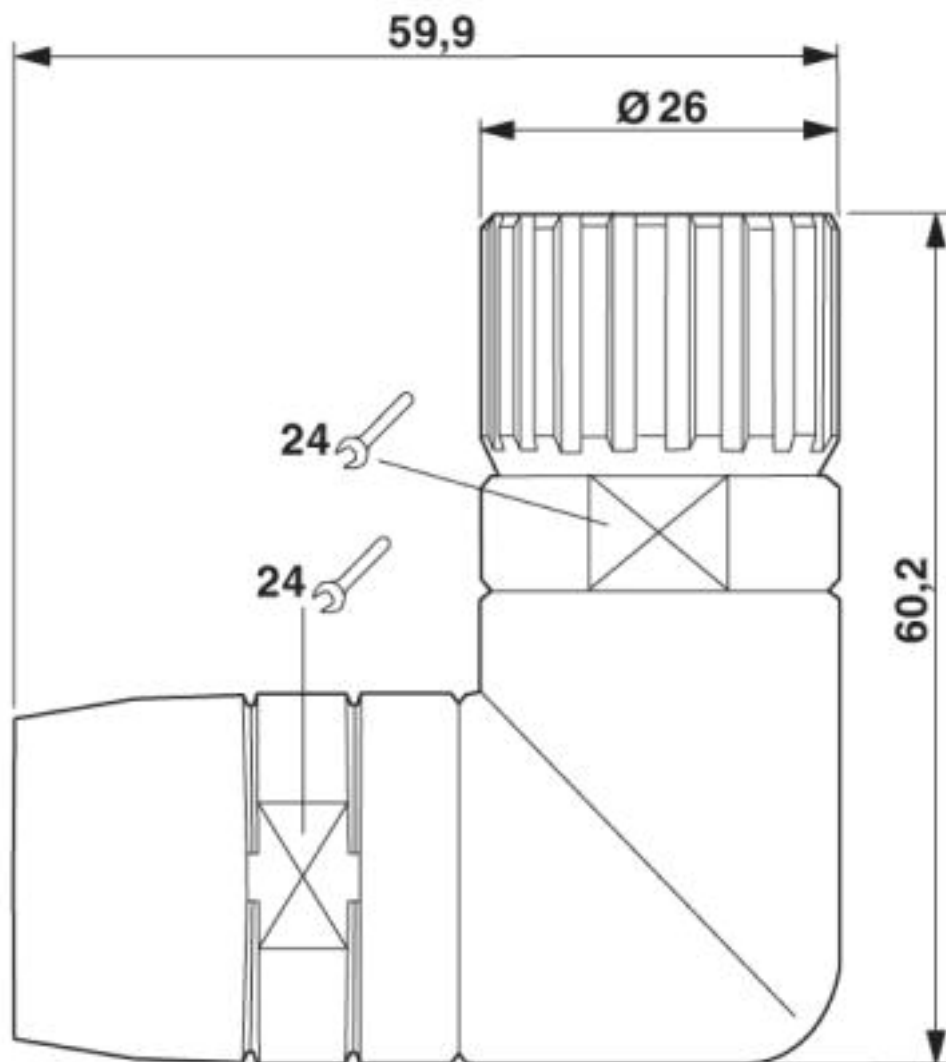

Cable connector - UC-17S1N8AT0DU - 1606605

Schematic diagram

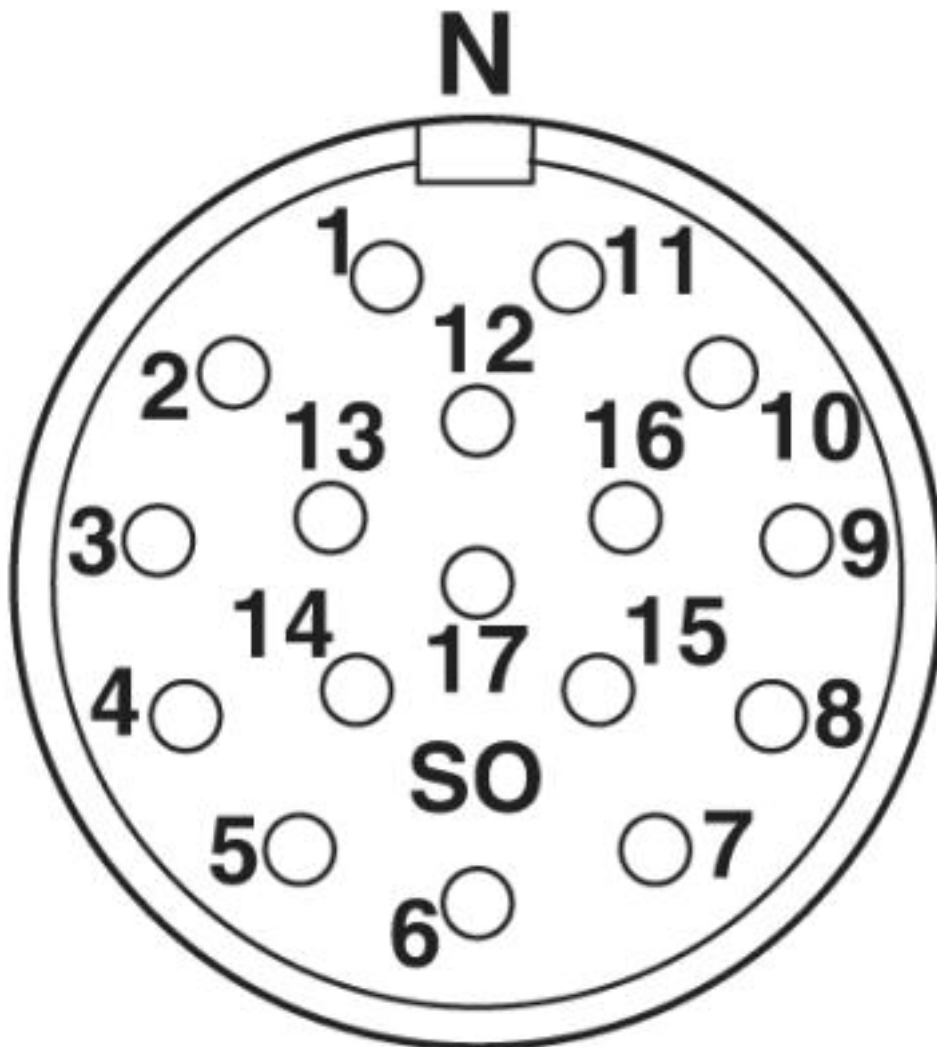

Approvals

Approvals

Approvals

EAC

Ex Approvals

Approval details

Cable connector - UC-17S1N8AT0DU - 1606605

Approvals

EAC



B.01742

Phoenix Contact 2019 © - all rights reserved
<http://www.phoenixcontact.com>

PHOENIX CONTACT GmbH & Co. KG
Flachsmarktstr. 8
32825 Blomberg
Germany
Tel. +49 5235 300
Fax +49 5235 3 41200
<http://www.phoenixcontact.com>