



APPLICATION SPECIFICATION

MX150 2X6 PANEL MOUNT CONNECTOR

1.0 SCOPE

This procedure applies to all part numbers in the 47725 series

2.0 PRODUCT DESCRIPTION

This Product Specification covers the 3.50 mm (0.138 inch) centerline (pitch) MX150 2x6 panel mount terminated with 14 to 22 AWG wire or ISO 0.35mm² to 1.5mm² wire. Designed to mate with MX150 2x6 receptacle connector terminated with Sn(Tin), Ag(Silver), Au(Gold) terminals, see PS-47725-000 section 4.4(vibration class) for terminal plating selection.



Polarization A

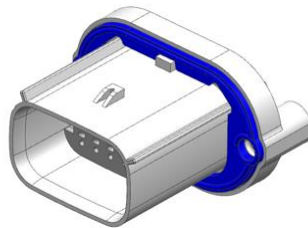

Polarization B



Polarization C

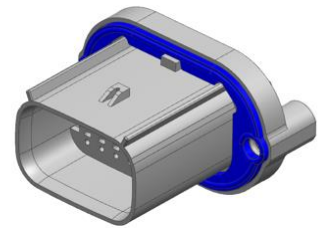

Polarization D

Application	Part numbers				Gasket Color
	Key A / Black	Key B / Light Gray	Key C / Dark Gray	Key D / Stone Gray	
UL HB	477251310	477251320	477251330	477251340	Gray
	477252010	477252020	477252030	477252040	Black
	477252110	477252120	477252130	477252140	Gray
	477256010	477256020	477256030	477256040	Blue
	477257010	477257020	477257030	477257040	Blue
UL V0	477259010	477259020	477259030	477259040	Blue

3.0 REFERENCE DOCUMENTS

Description	Document Number
MX150 2X6 Panel Mount Connector	SD-47725-130 SD-47725-210 SD-47725-601
Packaging Specification	RPK-47725-001
Product Specification	PS-47725-000
MX150 Application Specification	AS-33472-100
MX150 Blade Terminal	SD-33000-001
MX150 2x6 Receptacle Connector	SD-33472-0002
MX150 Receptacle Terminal	SD-33012-002
EJOT Screw Drawing	5000130-000

REVISION: E1	ECR/ECN INFORMATION: EC No: 627093 DATE: 2019/11/08	TITLE: MX150 2x6 Panel Mount Connector	SHEET No. 1 of 11
DOCUMENT NUMBER: AS-47725-001	CREATED / REVISED BY: Walker He	CHECKED BY: Elvis Song	APPROVED BY: Jun Deng



APPLICATION SPECIFICATION

Die cast Geometry

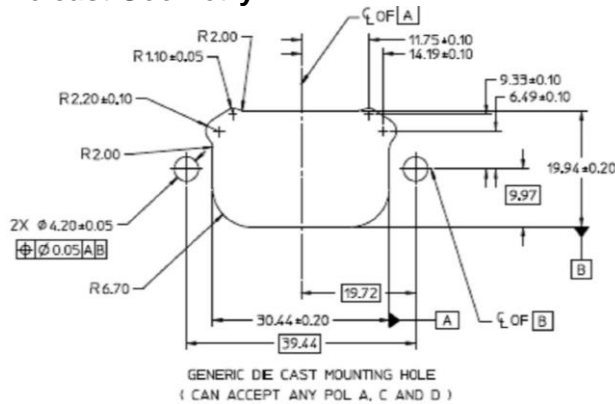

Option 1: This die cast applies to 4772513XX and 4772570XX series products

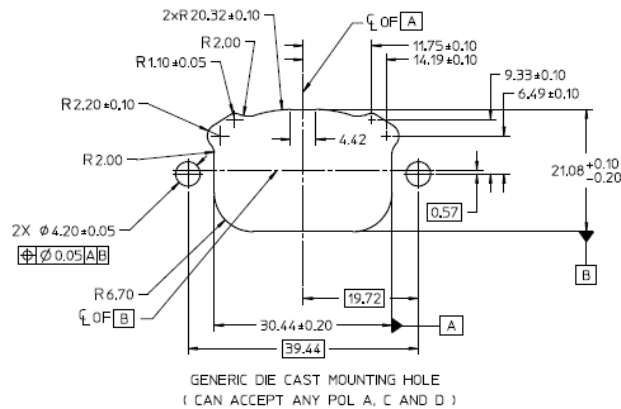

Option 2: This die cast applies to 477252XXX, 4772560XX and 4772590XX series products

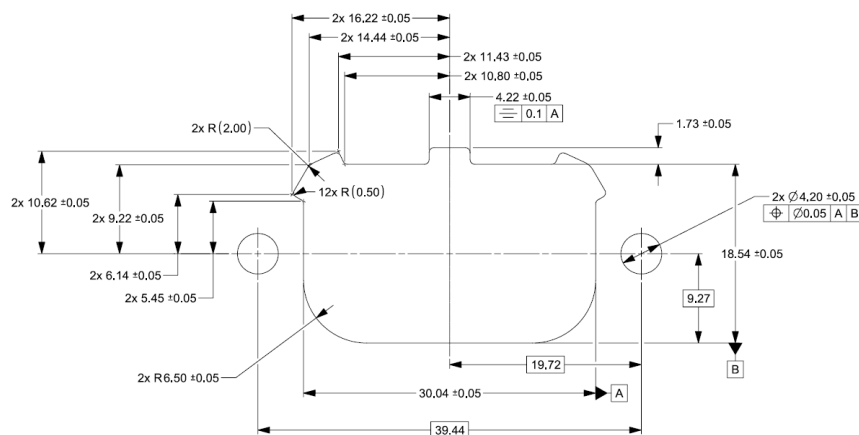

Option 3: This die cast applies to all 47725 series products (Recommended)

Notes: All the geometry are for reference only. Customers are required to complete their own validation testing if the geometry is different than what is shown in this specification.

REVISION: E1	ECR/ECN INFORMATION: EC No: 627093 DATE: 2019/11/08	TITLE: MX150 2x6 Panel Mount Connector	SHEET No. 2 of 11
DOCUMENT NUMBER: AS-47725-001	CREATED / REVISED BY: Walker He	CHECKED BY: Elvis Song	APPROVED BY: Jun Deng



APPLICATION SPECIFICATION

Screw Dimensions

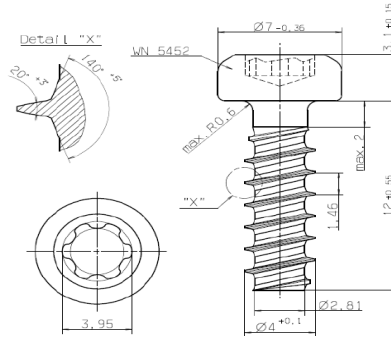

Mating surface requirements:

- Required mating surface finish: 3.5um maximum RA scale
- Required mating surface flatness: to 0.25mm
- Mating surface thickness: to be 2.8mm to 3.0mm
- Required screw: EJOT Delta PT Schraube WN5452 40X12
- Recommended screw torque: 1.5~1.7Nm

For wire size and current rating refer to the released Product Specification.

REVISION: E1	ECR/ECN INFORMATION: EC No: 627093 DATE: 2019/11/08	TITLE: MX150 2x6 Panel Mount Connector	SHEET No. 3 of 11
DOCUMENT NUMBER: AS-47725-001	CREATED / REVISED BY: Walker He	CHECKED BY: Elvis Song	APPROVED BY: Jun Deng



APPLICATION SPECIFICATION

4.0 PROCEDURE

Connector Assembly

A. "As Shipped" connector position

TPA shown in "as shipped" condition.

The TPA should remain in the pre-lock position until all circuits are loaded.

The TPA should never be removed from the connector!



B. Terminal Installation:

With TPA still in pre-lock position, orient terminal to rear of connector. Grip the wire no less than 1.25 inches from the terminal insulation crimp and insert through appropriate circuit opening. If resistance is encountered, retract the terminal and adjust the angle of insertion. Continue inserting the terminal until it stops and locks up on the lock finger with an audible click.

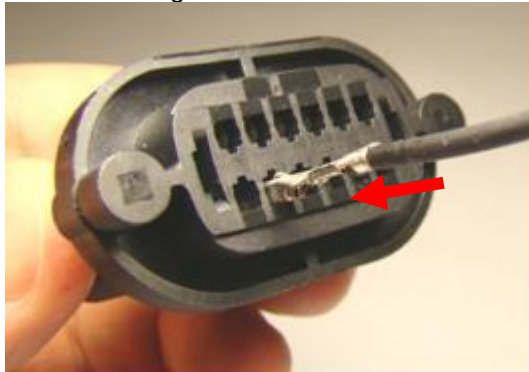

PUSH

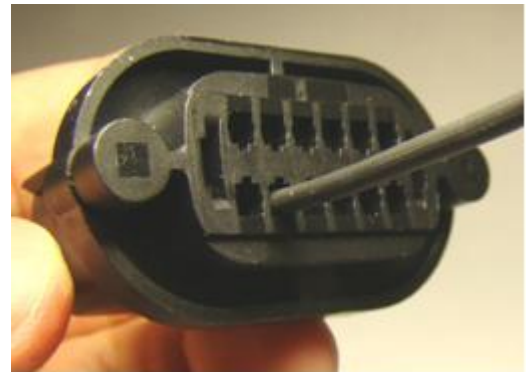

CLICK

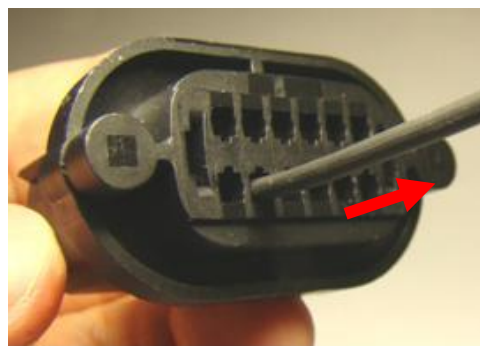

PULL

REVISION: E1	ECR/ECN INFORMATION: EC No: 627093 DATE: 2019/11/08	TITLE: MX150 2x6 Panel Mount Connector	SHEET No. 4 of 11
DOCUMENT NUMBER: AS-47725-001	CREATED / REVISED BY: Walker He	CHECKED BY: Elvis Song	APPROVED BY: Jun Deng



APPLICATION SPECIFICATION

C. Seating the TPA

With the Receptacle terminals fully installed, the TPA can be seated into its final lock position by applying an even force to the TPA surface until it comes to a stop, with an audible click.

The TPA should never be fully removed!

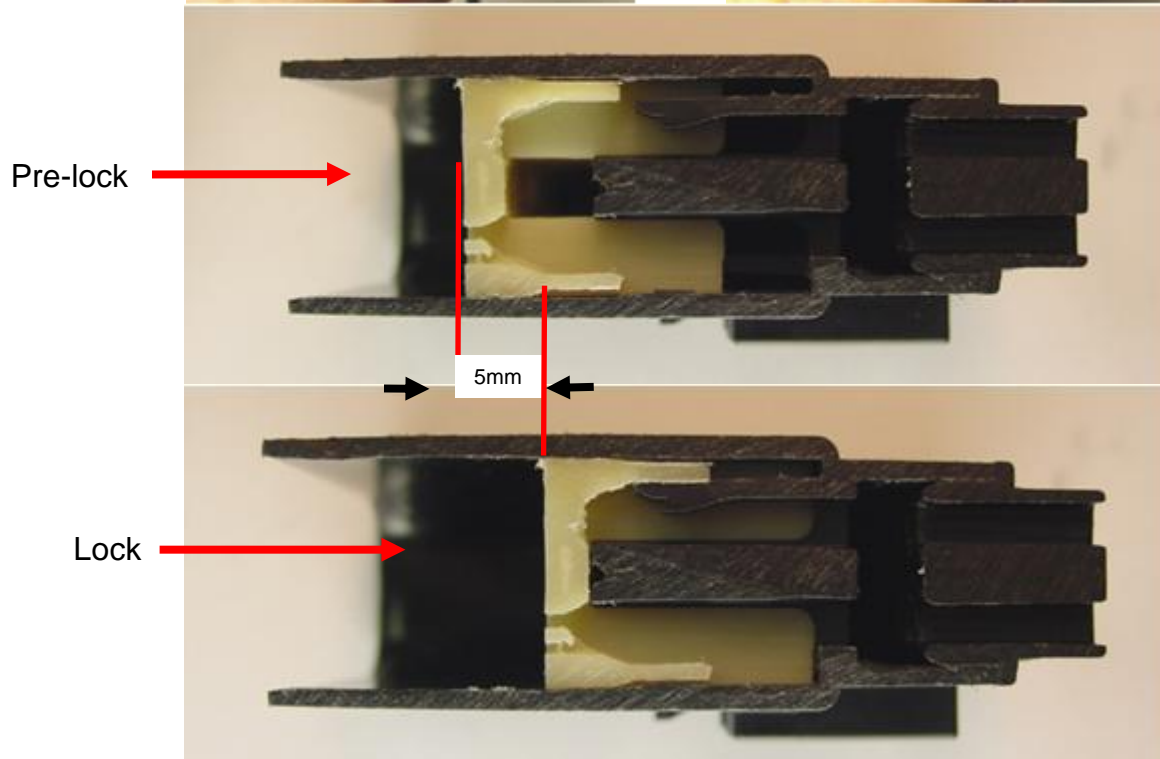
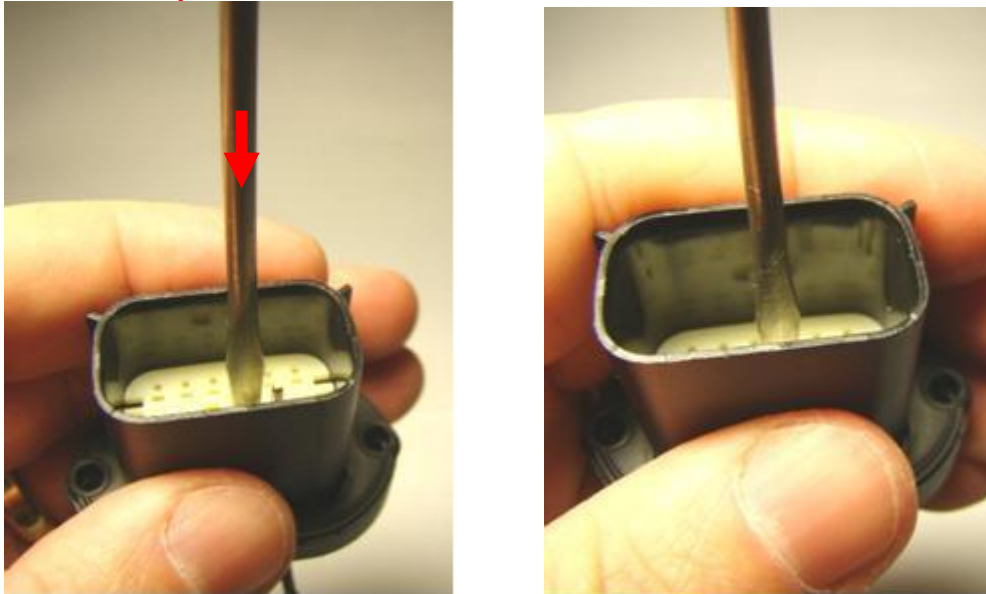

Cross section of TPA in pre / lock

REVISION: E1	ECR/ECN INFORMATION: EC No: 627093 DATE: 2019/11/08	TITLE: MX150 2x6 Panel Mount Connector	SHEET No. 5 of 11
DOCUMENT NUMBER: AS-47725-001	CREATED / REVISED BY: Walker He	CHECKED BY: Elvis Song	APPROVED BY: Jun Deng



APPLICATION SPECIFICATION

D. Connector Mating

Note and align connector keying features, from connector to header.
Begin mating procedure by sliding the connector and header together, press firmly until you hear an audible click

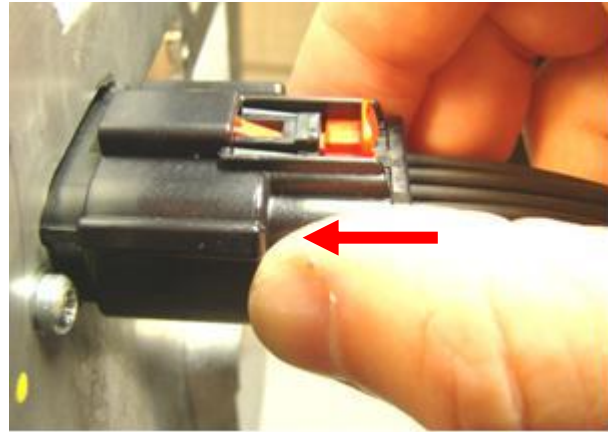

E. Connector Mating (CPA option shown)

Once together the final step will be locking the CPA. Simply press the center of the CPA, until you see/feel positive engagement.

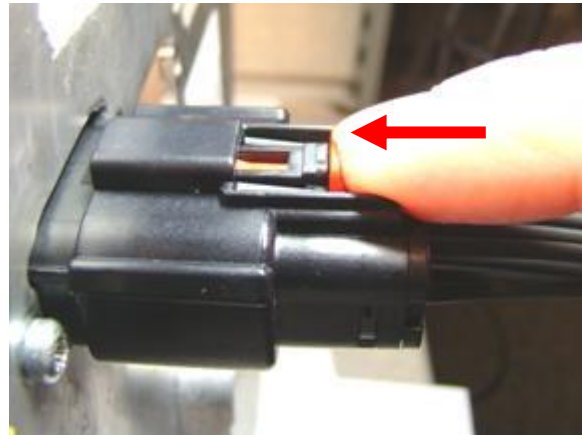

REVISION: E1	ECR/ECN INFORMATION: EC No: 627093 DATE: 2019/11/08	TITLE: MX150 2x6 Panel Mount Connector	SHEET No. 6 of 11
DOCUMENT NUMBER: AS-47725-001	CREATED / REVISED BY: Walker He	CHECKED BY: Elvis Song	APPROVED BY: Jun Deng



APPLICATION SPECIFICATION

F. Un-mate procedure (servicing)

To un-mate the connectors, pull back on the CPA (step1). Push connector together to unload the latch system. Then depress the latch with your thumb, Continue to depress the latch, and gently pull apart connector assemblies (step2).

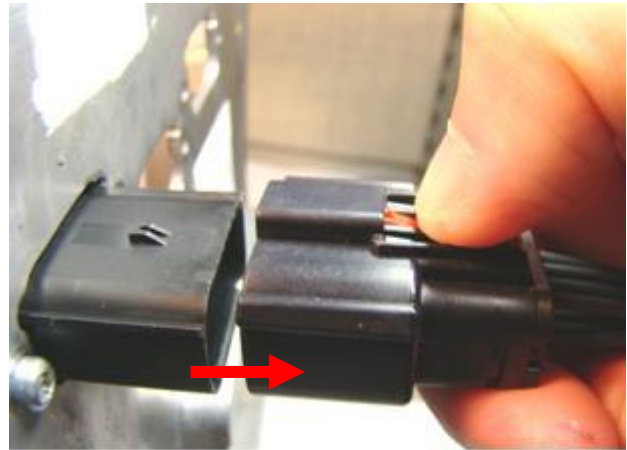
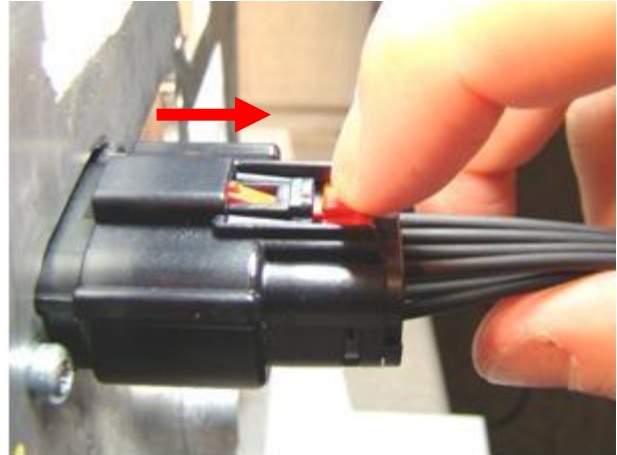

REVISION: E1	ECR/ECN INFORMATION: EC No: 627093 DATE: 2019/11/08	TITLE: MX150 2x6 Panel Mount Connector	SHEET No. 7 of 11
DOCUMENT NUMBER: AS-47725-001	CREATED / REVISED BY: Walker He	CHECKED BY: Elvis Song	APPROVED BY: Jun Deng



APPLICATION SPECIFICATION

G. TPA servicing

Step 1: Insert a small pair of pliers into the designated pry point

Step 2: Gently pull out on the TPA until it reaches pre-lock position (see sheet 4)

The TPA should never be fully removed from the connector housing! Excessive force may damage the TPA!

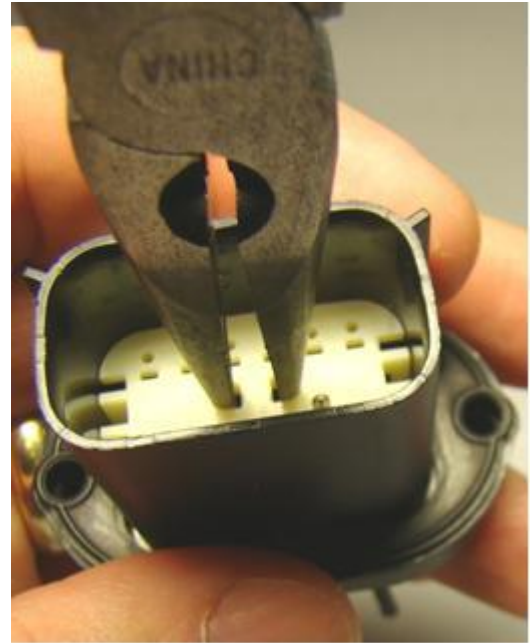
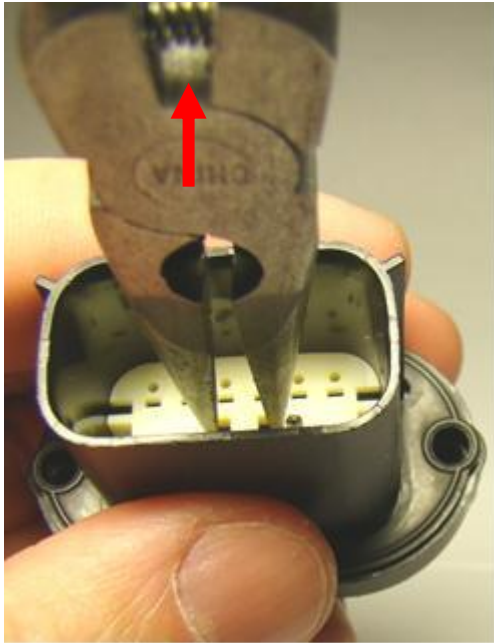

H. Terminal removal

Insert the designated service tool into the terminal service opening. Push down to release terminal locking finger.

Do not use excessive force; excessive force can damage the lock finger!



REVISION: E1	ECR/ECN INFORMATION: EC No: 627093 DATE: 2019/11/08	TITLE: MX150 2x6 Panel Mount Connector	SHEET No. 8 of 11
DOCUMENT NUMBER: AS-47725-001	CREATED / REVISED BY: Walker He	CHECKED BY: Elvis Song	APPROVED BY: Jun Deng



APPLICATION SPECIFICATION

H. Terminal removal (continued)

Step 3: Once the Lock finger is disengaged, gently pull on the wire to release the terminal. If the terminal resists, the service tool may not be fully engaged. Push the service tool further into the service Opening to ensure that it has fully disengaged the locking finger.

Do not insert the service tool into the terminal opening!

Do not use excessive force; excessive force can damage the lock finger!



REVISION: E1	ECR/ECN INFORMATION: EC No: 627093 DATE: 2019/11/08	TITLE: MX150 2x6 Panel Mount Connector	SHEET No. 9 of 11
DOCUMENT NUMBER: AS-47725-001	CREATED / REVISED BY: Walker He	CHECKED BY: Elvis Song	APPROVED BY: Jun Deng



APPLICATION SPECIFICATION

I. Mounting connector to casting

Align connector with keyway and mounting holes. Hold connector firmly in place against the flat surface of casting. Be sure to align each screw in line with mounting holes. Be sure to use the recommended screw and torque driver. Torque driver should be set at half the of the final recommended torque specification.

Each mounting screw requires a two step torque process!
Misaligned screws can damage the connector housing!

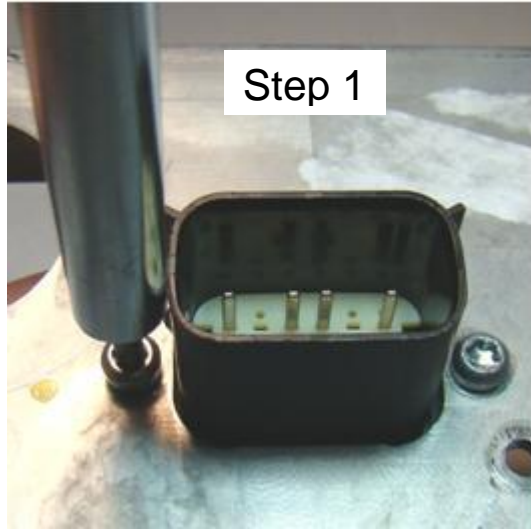

Step 1



Step 2

Each screw at half of final

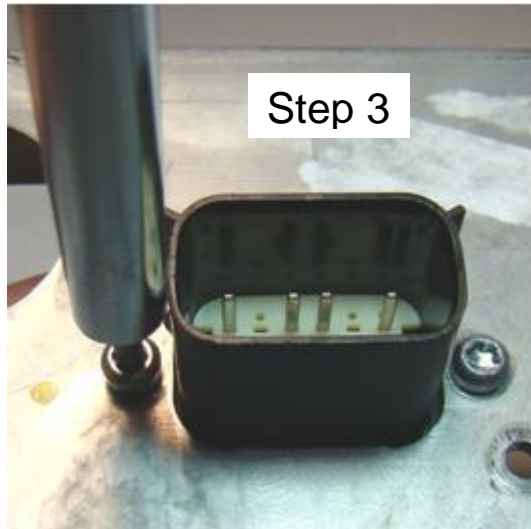

Step 3



Step 4

Each screw at final

REVISION: E1	ECR/ECN INFORMATION: EC No: 627093 DATE: 2019/11/08	TITLE: MX150 2x6 Panel Mount Connector	SHEET No. 10 of 11
DOCUMENT NUMBER: AS-47725-001	CREATED / REVISED BY: Walker He	CHECKED BY: Elvis Song	APPROVED BY: Jun Deng



APPLICATION SPECIFICATION

J. Notes

- Once the Connector has been fastened/ screwed onto the panel it is not serviceable and must be replaced
- The harness maker must guarantee an appropriate protection for gasket regarding storage, transport and using conditions to prevent gasket from losing

REVISION: E1	ECR/ECN INFORMATION: EC No: 627093 DATE: 2019/11/08	TITLE: MX150 2x6 Panel Mount Connector	SHEET No. 11 of 11
DOCUMENT NUMBER: AS-47725-001	CREATED / REVISED BY: Walker He	CHECKED BY: Elvis Song	APPROVED BY: Jun Deng