

# Sleeve frame - VC-TR1/2M - 1852891

Please be informed that the data shown in this PDF Document is generated from our Online Catalog. Please find the complete data in the user's documentation. Our General Terms of Use for Downloads are valid (<http://phoenixcontact.com/download>)



Sleeve frame, without PE, for contact insert modules, type 1, number of insert modules 2



## Key Commercial Data

Packing unit	5 pc
Minimum order quantity	5 pc
GTIN	 4 017918 133757
GTIN	4017918133757

## Technical data

### Dimensions

Height	27.5 mm
Width	50.2 mm
Length	20.2 mm

### Ambient conditions

Ambient temperature (operation)	-40 °C ... 100 °C
---------------------------------	-------------------

### General

Size	VC1
Material	PA-GF
Housing material	PA 6.6
Cable gland material	Steel, galvanized
Flammability rating according to UL 94	V0

### Standards and Regulations

Halogen-free	yes
Connection in acc. with standard	CUL
Flammability rating according to UL 94	V0

# Sleeve frame - VC-TR1/2M - 1852891

## Technical data

### Environmental Product Compliance

China RoHS	Environmentally friendly use period: unlimited = EFUP-e
	No hazardous substances above threshold values

## Drawings

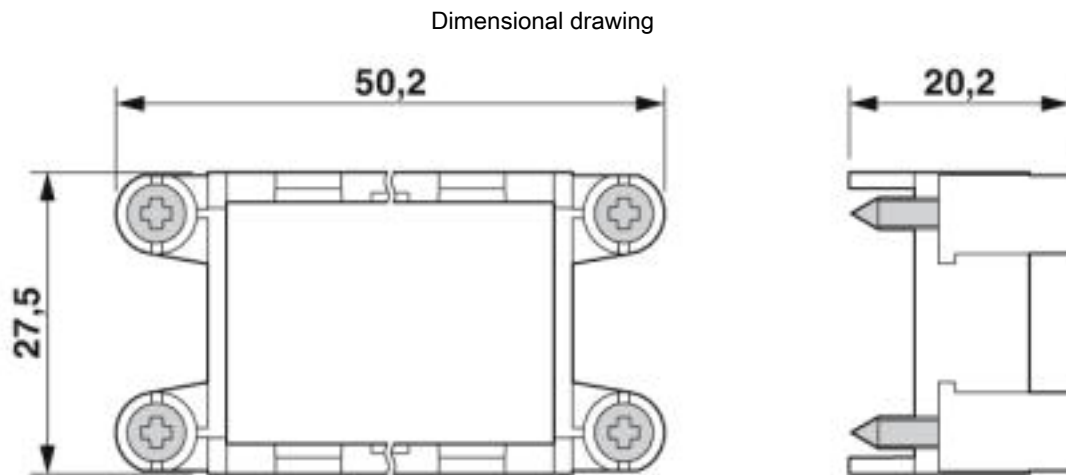

## Approvals

### Approvals

#### Approvals

UL Recognized / cUL Recognized / EAC / cULus Recognized

#### Ex Approvals

### Approval details

UL Recognized		<a href="http://database.ul.com/cgi-bin/XYV/template/LISEXT/1FRAME/index.htm">http://database.ul.com/cgi-bin/XYV/template/LISEXT/1FRAME/index.htm</a>	FILE E 118976
---------------	--	-------------------------------------------------------------------------------------------------------------------------------------------------------	---------------

cUL Recognized		<a href="http://database.ul.com/cgi-bin/XYV/template/LISEXT/1FRAME/index.htm">http://database.ul.com/cgi-bin/XYV/template/LISEXT/1FRAME/index.htm</a>	FILE E 118976
----------------	--	-------------------------------------------------------------------------------------------------------------------------------------------------------	---------------

EAC			B.01742
-----	--	--	---------

## Sleeve frame - VC-TR1/2M - 1852891

### Approvals

cULus Recognized



Phoenix Contact 2019 © - all rights reserved  
<http://www.phoenixcontact.com>

PHOENIX CONTACT GmbH & Co. KG  
Flachsmarktstr. 8  
32825 Blomberg  
Germany  
Tel. +49 5235 300  
Fax +49 5235 3 41200  
<http://www.phoenixcontact.com>